

- A – Stainless Steel Flexible Membranes
- B – Overload and Anti-Fly Protection Collars
- C – Anti-Corrosion Treatment
- D – Membrane Unit Assembly for Ease of Fitting
- E – Fitted Bolts for Balance Integrity
- F – Scalloped Hubs to Maximize Bore

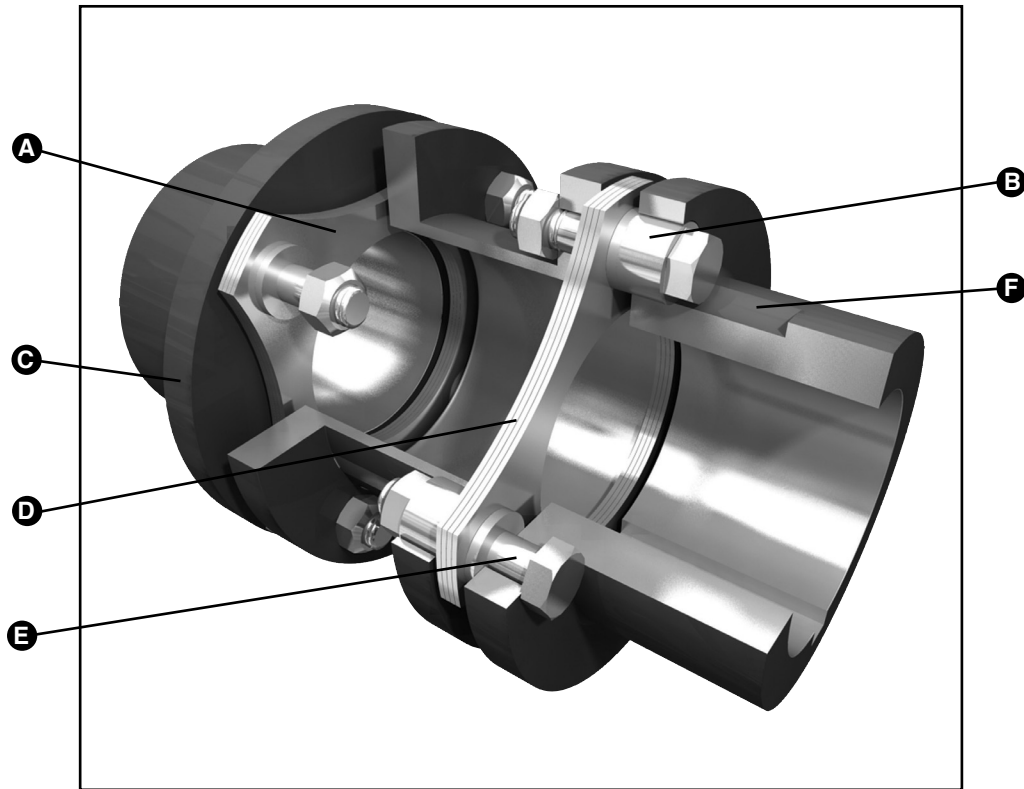

Product Description

John Crane's Metastream® L Series range of membrane couplings has been specifically designed to provide a cost effective solution for demanding industrial applications. The couplings are selected by their torque capacity, with the scalloped hub providing the right size for the shaft.

- Easy to install
- Operates in either direction
- A Hubs supplied either finish machined or solid
- Coated carbon steel hardware for corrosion protection
- Choice of hub configuration to suit the shaft diameter
- Complies with ATEX 95 for use in hazardous environments on Group II category 2 equipment

Design Features

- **Fit and Forget** - Designed for infinite life, and with correct machinery alignment, often outlasts the machines it is connected to
- **Overload Protection** - Fitted with overload collars to protect the membranes in the event of severe torsional overload
- **Low Imposed Loads** - Designed to optimize their torque capability, while minimizing the reaction forces due to misalignment so reducing machinery vibration and maximizing bearing life
- **Zero Maintenance** - No relative moving parts, and hence requires no lubrication or maintenance
- **No Backlash** - Designed with fitted bolts, and torsionally stiff membranes ensures that there is zero backlash, making the coupling ideal for drives applications where constant speed without fluctuations is crucial

L Series Technical Data (Imperial)

Coupling Size	Rating	Max. Continuous Torque lb.in.	Peak Overload Torque lb.in.	Max. Unbalanced Speed rpm	Max. Balanced Speed rpm	Weight Coupling		Weight Unbored Hub lb.
	HP/100 rpm					Min. Std DBSE lb.	Extra DBSE lb./in.	
LDES-0007	0.9	620	1,239	7,000	22,000	4.01	0.11	0.93
LDES-0014	1.9	1,150	2,301	6,500	20,000	4.41	0.13	1.45
LDES-0028	3.7	2,390	4,868	6,000	18,000	8.6	0.27	2.98
LSES-0045	6	3,806	7,965	6,000	18,000	9.7	0.27	3.48
LSES-0090	12	7,611	15,045	5,200	15,000	18.9	0.39	6.99
LSES-0175	23	14,602	29,205	4,800	12,300	33.1	0.63	12.1
LSES-0265	35	22,125	44,250	4,400	10,800	55.6	0.79	21.2
LSES-0525	70	44,250	88,500	4,200	9,000	87.5	1.4	32.4
LSES-0810	109	68,145	137,175	4,000	7,800	123	1.9	45.4
LSES-1150	154	97,350	194,700	3,800	7,000	170	2.5	63.9
LESE-1560	209	132,750	265,500	3,700	6,000	234	3	86
LLES-1850	248	155,760	309,750	2,500	5,500	229	2.5	79.4
LLES-3000	402	253,110	504,450	2,250	5,200	364	3.5	132
LLES-4200	563	354,000	708,000	2,100	4,700	518	4	192
LLES-6000	805	504,450	1,017,750	2,000	4,200	754	5.3	267
LLES-9009	1,207	761,100	1,504,550	1,750	3,600	1,135	8.3	412
LLES-9012	1,609	1,017,750	2,035,500	1,600	3,200	1,488	10.2	540
LLES-9015	2,012	1,239,000	2,478,000	1,500	3,000	1,852	12.6	701
LLES-9025	3,353	2,079,750	4,159,500	1,400	2,600	3,153	12.9	1,224

L Series Typical Arrangement

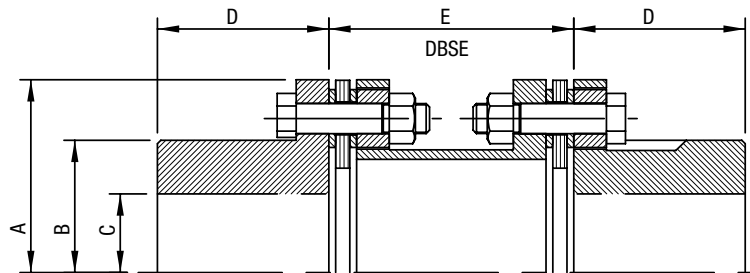

L Series Imperial Dimensional Data (Inches)

Coupling Size	A in	B in	(1) C Max Bore in	D in	E - DBSE						
					Absolute Min (in)	Preferred Min (in)	3.5 in	4.38 in	5 in	7 in	9 in
LDES-0007	2.48	1.63	1.18	1.3	1.57	1.57	X	X	X		
LDES-0014	2.91	1.94	1.38	1.5	1.57	1.57	X	X	X		
LDES-0028	3.72	2.65	1.89	1.65	1.69	1.69	X	X	X	X	
LSES-0045	3.72	2.61	1.85	2.05	1.69	1.69	X	X	X	X	
LSES-0090	4.72	3.4	2.44	2.44	2.13	2.13	X	X	X	X	
LSES-0175	5.71	4.07	2.95	2.95	2.52	2.52			X	X	
LSES-0265	6.77	4.94	3.54	3.54	2.91	2.91			X	X	
LSES-0525	7.76	5.65	4.06	4.13	3.35	3.35				X	X
LSES-0810	8.74	6.36	4.53	4.57	3.82	3.82				X	X
LSES-1150	9.72	7.12	5.08	5.12	4.21	4.21				X	X
LESE-1560	10.71	7.83	5.59	5.71	4.76	4.76					X
LLES-1850	11.5	7.56	5.39	5.39	5.47	7.09					X
LLES-3000	13.43	9.02	6.42	6.42	6.1	7.09					X
LLES-4200	15.12	10.24	7.28	7.32	6.69	7.09					
LLES-6000	16.89	11.38	8.11	8.11	7.76	9.84					
LLES-9009	19.13	13.23	9.41	9.45	8.58	9.84					
LLES-9012	21.06	14.45	10.31	10.31	9.37	9.84					
LLES-9015	22.48	15.87	11.3	11.34	9.76	9.84					
LLES-9025	26.89	19.13	13.62	13.66	10.87	11.81					

Notes:

- 1 Maximum bore shown are based on standard ANSI/AGMA square key dimensions for size 0007 through 3000 and rectangular key dimensions for size 4200 through 9025.
- Dimensions should not be used for construction. Certified dimensions furnished upon request.
- X These Distance Between Shaft End (DBSE) sizes are more readily available. Other lengths to suit specific shaft separations are available.

L Series Technical Data (Metric)

Coupling Size	Rating	Max. Continuous Torque	Peak Overload Torque	Max. Unbalanced Speed	Max. Balanced Speed	Weight Coupling		Weight Unbored Hub
	kW/1000 rpm	kNm	kNm	rpm	rpm	Min. Std DBSE Kg.	Extra DBSE Kg/m.	Kg.
LDES-0007	7	0.07	0.14	7,000	22,000	1.82	7.14	0.42
LDES-0014	14	0.13	0.26	6,500	20,000	2	2.31	0.66
LDES-0028	28	0.27	0.54	6,000	18,000	3.9	4.8	1.35
LSES-0045	45	0.43	0.86	6,000	18,000	4.4	4.8	1.58
LSES-0090	90	0.86	1.7	5,200	15,000	8.6	7	3.17
LSES-0175	175	1.65	3.3	4,800	12,300	15	11.3	5.5
LSES-0265	265	2.5	5	4,400	10,800	25.2	14.2	9.6
LSES-0525	525	5	10	4,200	9,000	39.7	24.8	14.7
LSES-0810	810	7.7	15.5	4,000	7,800	55.8	34.3	20.6
LSES-1150	1,150	11	22	3,800	7,000	77	44	29
LESE-1560	1,560	15	30	3,700	6,000	106	54	39
LLES-1850	1,850	17.6	35	2,500	5,500	104	45	36
LLES-3000	3,000	28.6	57	2,250	5,200	165	62	60
LLES-4200	4,200	40.1	80	2,100	4,700	235	71	87
LLES-6000	6,000	57.3	115	2,000	4,200	342	95	121
LLES-9009	9,000	86	172	1,750	3,600	515	149	187
LLES-9012	12,000	115	230	1,600	3,200	675	183	245
LLES-9015	15,000	143	286	1,500	3,000	840	225	318
LLES-9025	25,000	238	476	1,400	2,600	1,430	230	555

L Series Typical Arrangement

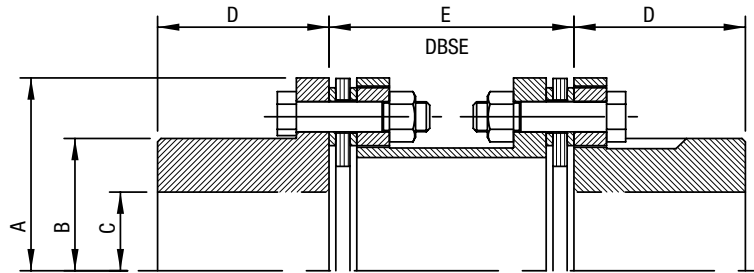

L Series Dimensional Data (mm)

Coupling Size	A mm	B mm	(1) C Max Bore mm	D mm	E - DBSE					
					Absolute Min (mm)	Preferred Min (mm)	(Min.) mm	100 mm	140 mm	180 mm
LDES-0007	63	41	30	33	40	100	X	X	X	
LDES-0014	74	49	35	38	40	100	X	X	X	X
LDES-0028	95	67	48	42	43	100	X	X	X	X
LSES-0045	95	66	47	52	43	100	X	X	X	X
LSES-0090	120	86	62	62	54	100	X	X	X	X
LSES-0175	145	103	75	75	64	100	X	X	X	X
LSES-0265	172	125	90	90	74	100		X	X	X
LSES-0525	197	144	103	105	85	140			X	X
LSES-0810	222	162	115	116	97	140			X	X
LSES-1150	247	181	129	130	107	140			X	X
LESE-1560	272	199	142	145	121	180				X
LLES-1850	292	192	137	137	139	180				
LLES-3000	341	229	163	163	155	180				
LLES-4200	384	260	185	186	170	180				
LLES-6000	429	289	206	206	197	250				
LLES-9009	486	336	239	240	218	250				
LLES-9012	535	367	262	262	238	250				
LLES-9015	571	403	287	288	248	250				
LLES-9025	683	486	346	347	276	300				

Notes:

1 Maximum bore based on standard DIN/BS rectangular keys.

• Dimensions should not be used for construction. Certified dimensions furnished upon request.

• X These Distance Between Shaft End (DBSE) sizes are more readily available. Other lengths to suit specific shaft separations are available.

Selection Procedure (Metric)

1. Select appropriate service factor (SF)
2. Calculate the coupling rating R from:

$$R = \frac{kW \times 1000 \times SF}{N}$$

Where:

kW = rated power for driven equipment (kW)
N = speed (rev./min)

3. Select a coupling with the same or higher rating.
4. Check DBSE.
5. Check the hub bore capacity is suitable, if not select a larger size coupling.
6. Check peak torque capability is suitable for application
7. Check speed capability.
8. Specify DBSE as appropriate.

Selection Procedure (Imperial)

1. Select appropriate service factor (SF)
2. Calculate the coupling rating R from:

$$R = \frac{HP \times 100 \times SF}{N}$$

Where:

HP = rated power for driven equipment (HP)
N = speed (rpm)

3. Select a coupling with the same or higher rating.
4. Check DBSE.
5. Check the hub bore capacity is suitable, if not select a larger size coupling.
6. Check peak torque capability is suitable for application.
7. Check speed capability.
8. Specify DBSE as appropriate.

Service Factor (SF)

Suggested service factors for electric motor, steam turbine, and gas turbine drivers are given below.

Torque Variation	Typical Application	Service Factor
Constant Torque	Centrifugal Pump Centrifugal Compressor Axial Compressor Centrifugal Blower	1.0*
Slight Torque Fluctuation	Screw Compressor Gear, Lobe and Vane Pumps Forced Draft Fan Medium Duty Mixer Lobe Blower	1.5
Substantial Torque Fluctuations	Reciprocating Pumps Heavy Duty Mixers Induced Draft Fans	2.0

*Use a minimum service factor of 1.25 on electric motor drives through a gearbox.

The examples given are for typical machines and are empirically based guidelines. Knowledge of actual torque characteristics may indicate a different service factor. Consult John Crane for advice.

KSelect is an internet based selection program for L Series. This selection program provides all necessary technical data including inertias and torsional stiffness.

Visit www.johncrane.com

Available Options

Spark-resistant couplings for hazardous zone operation.

Coupling Alignment

Correct installation and alignment of couplings is essential for reliable machinery performance.

The angular and axial restoring forces are available on request. The axial force has a nonlinear characteristic, which can de-tune systems to prevent high amplitude axial vibration.

L Series - Metric Misalignment Capabilities						L Series - Imperial Misalignment Capabilities					
Coupling Size	Max. Axial \pm mm	Equiva- lent Thrust kN	(1) Max. Angular Degrees	Restoring Moment at Max. Angle Nm	(2) Max. Parallel mm	Coupling Size	Max. Axial \pm in	Equiva- lent Thrust lbf	(1) Max. Angular Degrees	Restoring Moment at Max. Angle lb.in	(2) Max. Parallel in
0007	1.5	0.14	1	0.55	0.5	0007	0.06	31.5	1	4.87	0.02
0014	1.5	0.15	1	0.65	0.7	0014	0.06	34.2	1	5.75	0.027
0028	1.8	0.15	1	1.22	0.9	0028	0.07	33.3	1	10.8	0.035
0045	1.2	0.28	0.8	3.64	0.7	0045	0.05	62.9	0.8	32.2	0.027
0090	1.5	0.39	0.8	6.96	0.9	0090	0.06	87.9	0.8	61.6	0.035
0175	2	0.77	0.8	14.6	1.2	0175	0.08	172	0.8	130	0.047
0265	2.5	1.43	0.8	26.4	1.2	0265	0.1	322	0.8	234	0.047
0525	2.7	1.74	0.8	48	1.6	0525	0.11	390	0.8	425	0.063
0810	3.2	2.43	0.8	84	1.6	0810	0.13	547	0.8	743	0.063
1150	3.7	3.04	0.8	112	1.6	1150	0.15	683	0.8	991	0.063
1560	4.2	4.25	0.8	136	2	1560	0.17	955	0.8	1204	0.078
1850	3	2	0.5	77.5	1.4	1850	0.12	450	0.5	686	0.055
3000	4	3.85	0.5	110	1.4	3000	0.16	866	0.5	974	0.055
4200	4.4	4.5	0.5	160	1.3	4200	0.17	1012	0.5	1416	0.055
6000	5	5.6	0.5	208	1.9	6000	0.2	1259	0.5	1837	0.059
9009	6	7.5	0.5	300	1.9	9009	0.24	1686	0.5	2655	0.059
9012	6.8	8.6	0.5	390	1.9	9012	0.27	1933	0.5	3452	0.075
9015	7.5	9.8	0.5	435	1.9	9015	0.3	2203	0.5	3850	0.075
9025	8.8	11.3	0.5	510	2.3	9025	0.35	2540	0.5	4514	0.09

These values are maximums for each type of misalignment. It is recommended that the coupling is initially aligned to 10% of these values to allow for inevitable movement during the life of the machines

- (1) The values given are for each membrane bank.
- (2) These values are based on the standard minimum distance between shaft ends. (Min).

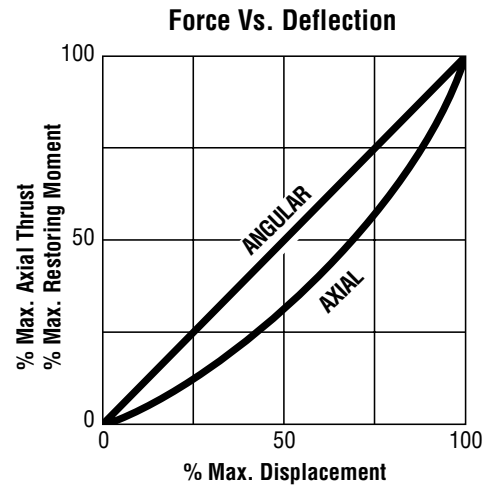

John Crane supplies a variety of shaft alignment equipment and offers alignment training courses. Lase-A-Lign™ EX Shaft Alignment System is one of the toughest and most robust measurement and alignment systems available. For alignment work in potentially explosive environments, equipment needs to be explosion-protected. Lase-A-Lign EX Shaft Alignment System complies with the latest ATEX standards for work in such environments.

Balance Condition

Balancing Limits

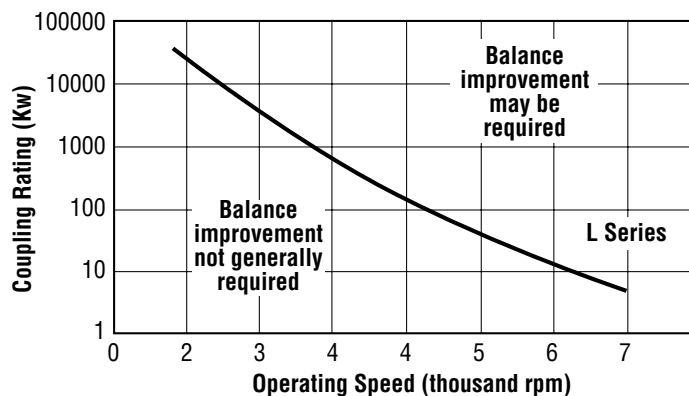

This coupling is designed with a high inherent balance, due to the precision of the manufacturing process. It is important that all parts are carefully stored and fitted to maintain this integrity.

The inherent balance of the L Series meets AGMA standard 9000-C90 class 8. The maximum operating speeds listed in the tables are on the basis of this AGMA class 8 characteristic, to provide a general guide to maximum permissible speed. If higher speeds are required contact John Crane for an alternative coupling selection.

john crane

L SERIES

METAL MEMBRANE COUPLING L SERIES

Technical Specification

john crane

L SERIES

METAL MEMBRANE COUPLING L SERIES

Technical Specification



North America
United States of America
Tel: 1-847-967-2400
Fax: 1-847-967-3915

Europe
United Kingdom
Tel: 44-1753-224000
Fax: 44-1753-224224

Latin America
Brazil
Tel: 55-11-3371-2500
Fax: 55-11-3371-2599

Middle East & Africa
United Arab Emirates
Tel: 971-481-27800
Fax: 971-488-62830

Asia Pacific
Singapore
Tel: 65-6518-1800
Fax: 65-6518-1803

If the products featured will be used in a potentially dangerous and/or hazardous process, your John Crane representative should be consulted prior to their selection and use. In the interest of continuous development, John Crane Companies reserve the right to alter designs and specifications without prior notice. It is dangerous to smoke while handling products made from PTFE. Old and new PTFE products must not be incinerated. ISO 9001 and ISO 14001 Certified, details available on request.