

TYPE 604/606/609

HIGH-TEMPERATURE METAL BELLOWS SEALS

Technical Specification

- A – Set Screws
- B – Socket Head Cap Screws
- C – Compression Ring
- D – Flexible Graphite Packing
- E – Bellows Assembly
- F – Insert/Primary Ring

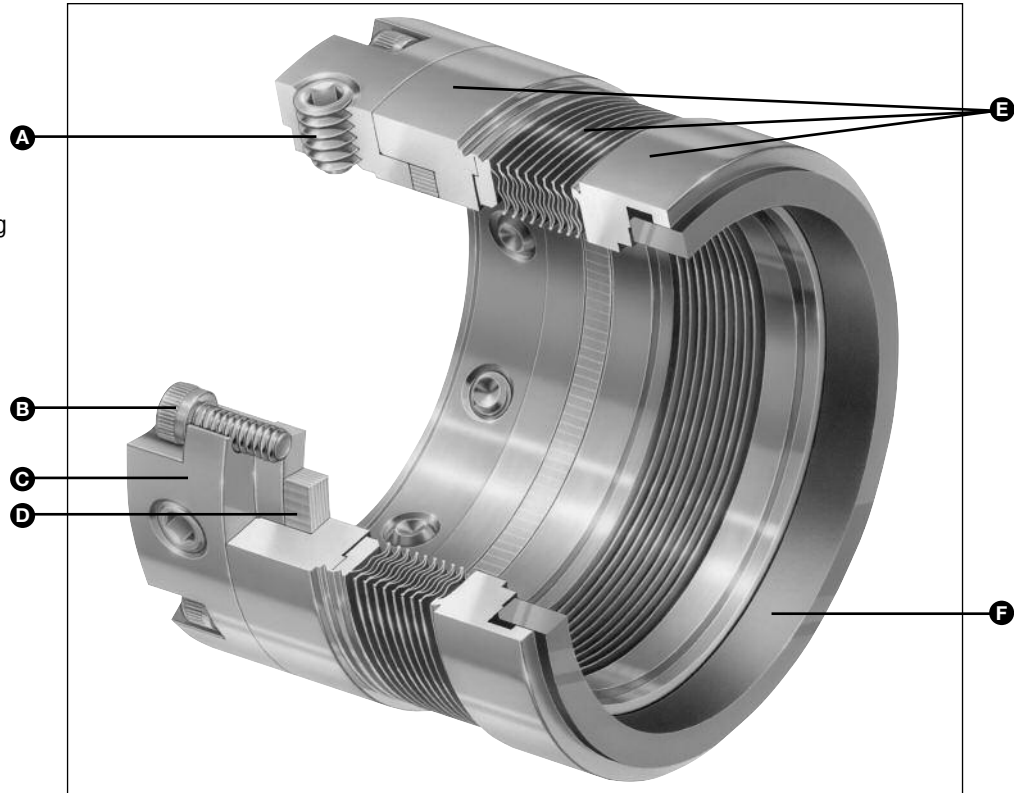

Sealol® Welded Metal Bellows

Type 609

Product Description

- Type 604 - High-temperature general-purpose stationary bellows assembly capable of handling high shaft speed applications and high shaft-to-seal chamber misalignment.
- Type 606 - High-temperature rotary bellows assembly with drive lugs under the bellows for additional rotational drive in viscous or thermosetting applications.
- Type 609 - High-temperature rotary bellows assembly with narrow cross-section design for easy fit.

Performance Capabilities

- Temperature: -75°C to + 425°C/-100°F to + 800°F (with flexible graphite static packing)
- Pressure: vacuum to 25 bar/360 psi vacuum to 69 bar/1,000 psi (with double-ply bellows) (see basic pressure ratings curve)
- Speed: up to 25m/s/5,000 fpm for Types 606 and 609 up to 50m/s/10,000 fpm for Type 604

Design Features

- Edge-welded metal bellows
- Elastomer-free design
- Standard components
- Available in single or dual cartridge arrangements
- Available with a secondary containment seal
- The Type 604 and Type 609 meet API 682 requirements
- Available with double-ply bellows

Typical Applications

- Aqueous solutions
- Aromatic fractionation products (benzene, toluene, solvents, etc.)
- Crude oil fractionation products (fuel oil, lubricating oil, gasoline, etc.)
- Heat transfer fluids
- Caustics
- Chemicals
- Hydrocarbons
- Lubricating fluids
- Some acids

TYPE 604/606/609

HIGH-TEMPERATURE METAL BELLOWS SEALS

Typical 604 Single Arrangement (API 682)

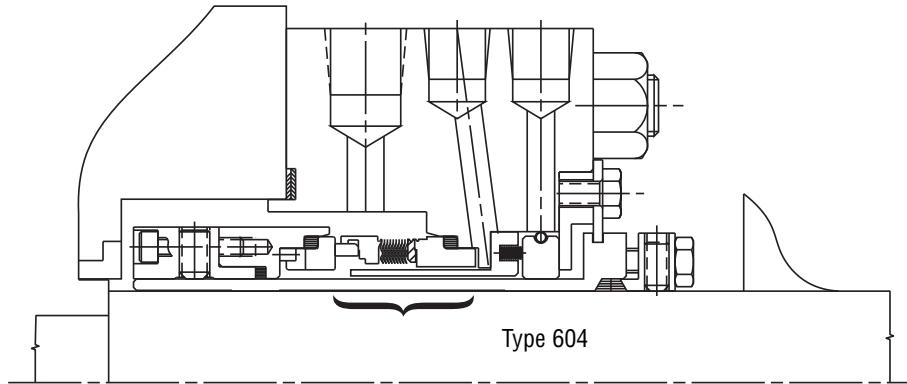

Typical 606 Single Arrangement

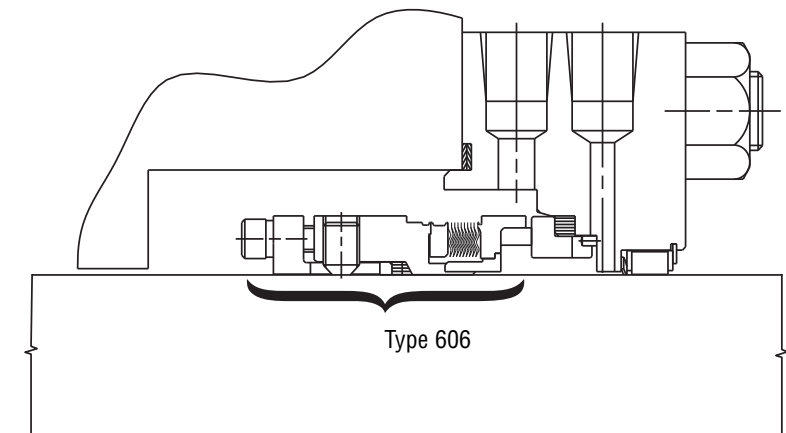

Typical 609/ECS Arrangement

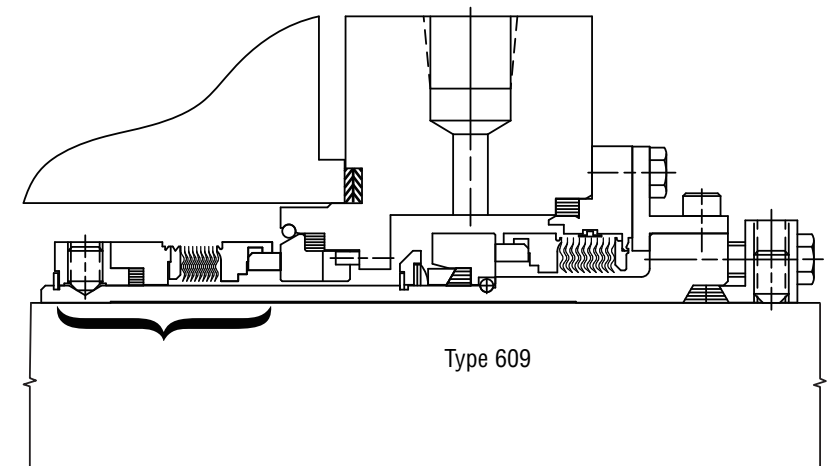

TYPE 604/606/609

HIGH-TEMPERATURE METAL BELLOWS SEALS

Typical 604 Dimensional Data

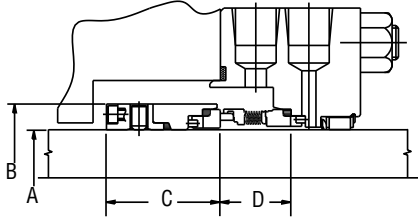

Seal Dash Number (size code)	Inch				mm			
	A + .000 - .002	B Ref.	C Ref.	D Ref.	A + .000 - .05	B Ref.	C Ref.	D Ref.
-18	1.000	1.937	1.969	1.138	25.40	49.20	50.01	28.91
-20	1.125	2.062	1.969	1.138	28.58	52.37	50.01	28.91
-22	1.250	2.187	1.969	1.138	31.75	55.55	50.01	28.91
-24	1.375	2.312	1.938	1.138	34.93	58.72	49.23	28.91
-26	1.500	2.562	2.063	1.191	38.10	65.07	52.40	30.25
-28	1.625	2.562	2.060	1.222	41.28	65.07	52.32	31.04
-30	1.750	2.687	2.060	1.254	44.45	68.25	52.32	31.85
-32	1.875	2.812	2.062	1.254	47.63	71.42	52.37	31.85
-34	2.000	2.937	2.060	1.285	50.80	74.60	52.32	32.64
-36	2.125	3.187	2.182	1.316	53.98	80.95	55.42	33.43
-38	2.250	3.312	2.218	1.348	57.15	84.12	56.34	34.24
-40	2.375	3.437	2.186	1.379	60.33	87.30	55.52	35.03
-42	2.500	3.562	2.184	1.410	63.50	90.47	55.47	35.81
-44	2.625	3.687	2.250	1.443	66.68	93.65	57.15	36.65
-46	2.750	3.937	2.250	1.608	69.85	100.00	57.15	40.84
-48	2.875	4.062	2.281	1.608	73.03	103.17	57.94	40.84
-50	3.000	4.187	2.250	1.608	76.20	106.35	57.15	40.84
-52	3.125	4.312	2.250	1.608	79.38	109.52	57.15	40.84
-54	3.250	4.437	2.219	1.608	82.55	112.70	56.36	40.84
-56	3.375	4.562	2.282	1.608	85.73	115.87	57.96	40.84
-58	3.500	4.687	2.373	1.650	88.90	119.05	60.27	41.91
-60	3.625	4.812	2.375	1.650	92.08	122.22	60.33	41.91
-62	3.750	4.937	2.375	1.650	95.25	125.40	60.33	41.91
-64	3.875	5.062	2.375	1.650	98.43	128.57	60.33	41.91

Note: "A" is the maximum shaft or sleeve diameter in arrangements excluding a steam guide sleeve.

Typical 606 Dimensional Data

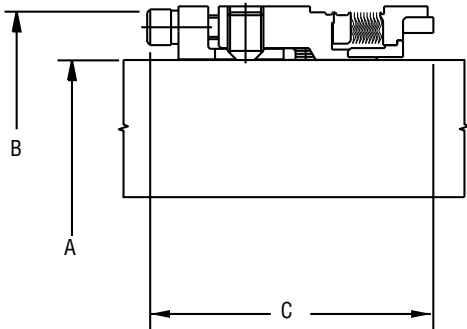

Seal Dash Number (size code)	Inch			mm		
	A + .000 - .002	B Ref.	C Ref.	A + .000 - .05	B Ref.	C Ref.
-16	.750	1.625	2.312	19.05	41.28	58.72
-18	.875	1.750	2.343	22.23	44.45	59.51
-20	1.000	1.875	2.343	25.40	47.63	59.51
-22	1.125	2.000	2.375	28.58	50.80	60.33
-24	1.250	2.125	2.375	31.75	53.98	60.33
-26	1.375	2.250	2.468	34.93	57.15	62.69
-28	1.500	2.375	2.500	38.10	60.33	63.50
-30	1.625	2.500	2.500	41.28	63.50	63.50
-32	1.750	2.625	2.531	44.45	66.68	64.29
-34	1.875	2.750	2.531	47.63	69.85	64.29
-36	2.000	2.875	2.562	50.80	73.03	65.07
-38	2.125	3.000	2.562	53.98	76.20	65.07
-40	2.250	3.250	2.750	57.15	82.55	69.85
-42	2.375	3.375	2.781	60.33	85.73	70.64
-44	2.500	3.500	2.781	63.50	88.90	70.64
-46	2.625	3.687	2.875	66.68	93.65	73.03
-48	2.750	3.812	3.000	69.85	96.82	76.20
-50	2.875	4.000	3.000	73.03	101.60	76.20
-52	3.000	4.125	3.000	76.20	104.78	76.20
-54	3.125	4.250	3.000	79.38	107.95	76.20
-56	3.250	4.375	3.000	82.55	111.13	76.20
-58	3.375	4.500	3.000	85.73	114.30	76.20
-60	3.500	4.625	3.000	88.90	117.48	76.20
-62	3.625	4.750	3.000	92.08	120.65	76.20
-64	3.750	4.875	3.000	95.25	123.83	76.20

TYPE 604/606/609

HIGH-TEMPERATURE METAL BELLOWS SEALS

Typical 609 Dimensional Data

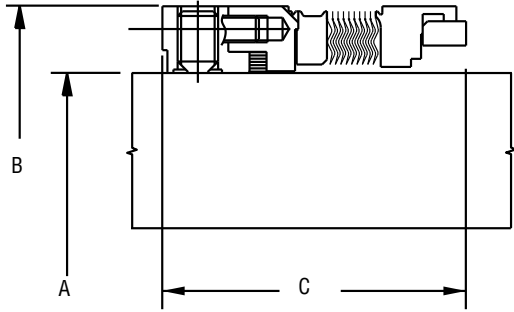

Seal Dash Number (size code)	Inch			mm		
	A +0.000 -0.002	B Ref.	C Ref.	A +0.000 -0.05	B Ref.	C Ref.
-16	1.000	1.625	1.531	25.40	41.28	38.89
-18	1.125	1.750	1.562	28.58	44.45	39.67
-20	1.250	1.875	1.593	31.75	47.63	40.46
-22	1.375	2.000	1.593	34.93	50.80	40.46
-24	1.500	2.125	1.593	38.10	53.98	40.46
-26	1.625	2.250	1.593	41.28	57.15	40.46
-28	1.750	2.375	1.625	44.45	60.33	41.28
-30	1.875	2.500	1.625	47.63	63.50	41.28
-32	2.000	2.625	1.656	50.80	66.68	42.06
-34	2.125	2.750	1.656	53.98	69.85	42.06
-36	2.250	2.875	1.719	57.15	73.03	43.66
-38	2.375	3.000	1.719	60.33	76.20	43.66
-40	2.500	3.250	1.750	63.50	82.55	44.45
-42	2.625	3.375	1.781	66.68	85.73	45.24
-44	2.750	3.500	1.781	69.85	88.90	45.24
-46	2.875	3.687	1.875	73.03	93.65	47.63
-48	3.000	3.812	1.875	76.20	96.82	47.63
-50	3.125	4.000	1.875	79.38	101.60	47.63
-52	3.250	4.125	1.875	82.55	104.78	47.63
-54	3.375	4.250	1.875	85.73	107.95	47.63
-56	3.500	4.375	1.875	88.90	111.13	47.63
-58	3.625	4.500	1.875	92.08	114.30	47.63
-60	3.750	4.625	1.875	95.25	117.48	47.63
-62	3.875	4.750	1.875	98.43	120.65	47.63
-64	4.000	4.875	1.875	101.60	123.83	47.63

Recommendations for Welded Metal Bellows

- 0 - 1,000 cSt: Standard Seal
- 1,000 - 3,500 cSt: Hard Face Material
- 3,500 - 7,500 cSt: Drive Lugs
- 7,500 - 10,500 cSt: Consult John Crane

NOTE: SSU (Saybolt Universal Seconds) approximately equals cSt (centistoke) x 4.6347cP (centipoise) = cSt (centistoke) x specific gravity.

Materials of Construction

DESCRIPTION	MATERIALS	
	Standard	Options
Seal Components		
Bellows	Alloy 718 (UNS N07718)	Heat Treated AM350 (UNS S35000)
Insert/Primary Ring	Premium Carbon Grade Silicon Carbide Tungsten Carbide	—
Static Seals	Flexible Graphite	—
Shell/Primary Ring Adaptor	Alloy 42 (UNS K94100)	—
Adaptor	Alloy 625 (UNS N06625)	347 Stainless Steel (UNS S34700)

Bellows design features

- Optimum 45° tilt angle
- Three-sweep radius
- Nesting ripple plate design
- Static secondary seal
- Light spring loads

Bellows benefits

- Uniform plate rigidity and stress distribution
- Enhanced fatigue strength
- Pressure-balanced by design
- Less heat generated
- Lower power consumption

TYPE 604/606/609

HIGH-TEMPERATURE METAL BELLOWS SEALS

Basic Pressure Rating

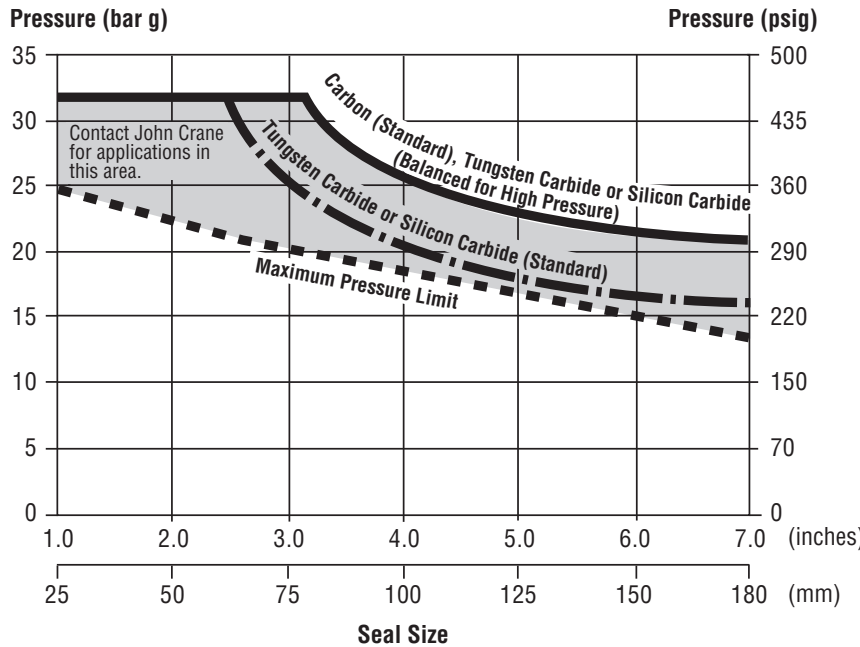

The basic pressure rating is for a standard seal, as shown in the typical arrangement, when installed according to the criteria given in this data sheet and generally accepted industrial practices.

The basic pressure rating assumes stable operation at 3600 rpm in a clean, cool, lubricating, non-volatile liquid with an adequate flush rate. When used with the multiplier factors, the basic pressure rating can be adjusted to provide a conservative estimate of the dynamic pressure rating.

Contact John Crane for process services outside this range for a more specific assessment of the dynamic pressure rating, or double-ply bellows pressure rating.

NOTES:

1. Basic pressure rating curve based on single-ply bellows.
2. Basic pressure rating curve is differential pressure applied to seal outside diameter.
3. Inside diameter differential pressure vs. temperature limits: if the inside diameter differential pressure is greater than 5 bar/75 psi or the operating temperature is greater than 315°C/600°F, consult John Crane.

Multiplier Factors

	Selection Consideration	Multiplier Factors	
		Carbon vs. SiC	SiC vs. SiC T/C vs. SiC
Speed	Up to 3600 rpm	x 1.00	x 1.00
	Above 3600 rpm	x (3600/speed)	x (3600/speed)
Sealed Fluid Lubricity	Petroleum/Gasoline, Kerosene, Lube Oil, etc...	x 1.00	x 1.00
	Water and Aqueous Solutions (< 80°C/176°F)	x 0.75	x 0.75
	Light Hydrocarbons (see Note 1)	x 0.60	(see Note 2)
Sealed Fluid Temperature (see Note 3)	Up to 80°C/176°F	x 1.00	x 1.00
	Up to 120°C/250°F	x 0.90	x 1.00
	Up to 205°C/400°F	x 0.80	x 1.00
	Up to 315°C/600°F	x 0.65	x 1.00
	Above 315°C/600°F	x 0.65	(see Note 4)

Example for Determining Pressure Rating Limits:

Seal: Type 604
 Size: 3.5" (89mm)
 Product: high viscosity gas oil
 Face material: carbon vs. silicon carbide
 Operating temperature: 325°C/620°F
 Operating speed: 3600 rpm

Example for determining dynamic pressure rating:

The maximum pressure for a particular application is the lesser of the maximum pressure limit curve or the pressure calculated when the multiplier factors are applied to the specific seal face material curve.

Maximum pressure limit curve:

19.5 bar(g)/283 psig max pressure

Carbon limit curve: 29.3 bar g/425 psig

Calculated limit: 29.3 bar g/425 psig x 1.00 x 1.00 x 0.65 = 19 bar g/276 psig

NOTES:

1. Specific gravity ≥ 0.6 and ratio of sealed pressure to vapor pressure > 1.5.
2. More details regarding the fluid and the operating conditions are required.
3. Temperature at the seal faces includes effects of flush, quench and cooling.
4. Contact John Crane for more information.

At 3600 rpm with the service conditions noted, an 3.5" (89mm) (Seal Size) Type 604 has a maximum operating pressure limit of 19 bar g/276 psig.

TYPE 604/606/609

HIGH-TEMPERATURE METAL BELLOWS SEALS

Technical Specification

Type 604 High-Temperature Metal Bellows

- A – Insert/Primary Ring
- B – Flexible Graphite Packing
- C – Bellows Assembly

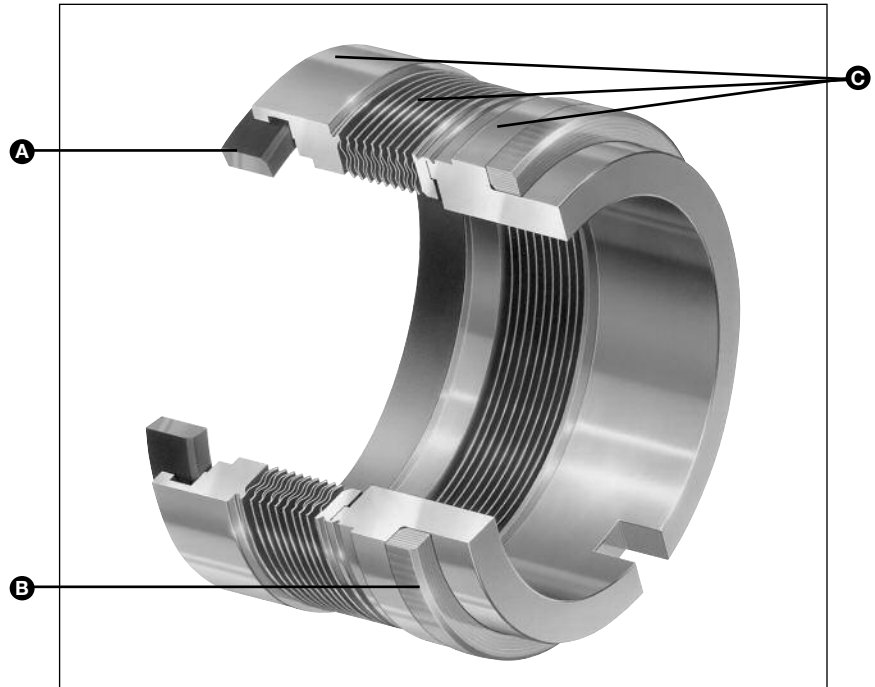

Type 606 High-Temperature Metal Bellows

- A – Socket Head Cap Screws
- B – Compression Ring
- C – Spacer Ring
- D – Bellows Assembly
- E – Set Screws
- F – Flexible Graphite Packing
- G – Drive Lugs
- H – Insert/Primary Ring

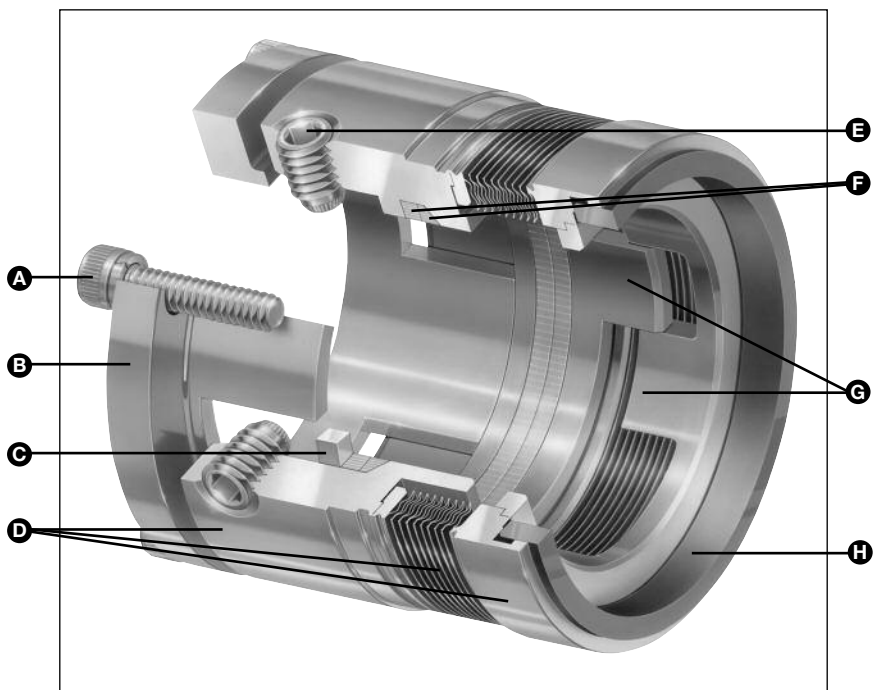

TYPE 604/606/609

HIGH-TEMPERATURE METAL BELLOWS SEALS

Technical Specification



North America	Europe	Latin America	Middle East & Africa	Asia Pacific
United States of America	United Kingdom	Brazil	United Arab Emirates	Singapore
Tel: 1-847-967-2400	Tel: 44-1753-224000	Tel: 55-11-3371-2500	Tel: 971-481-27800	Tel: 65-6518-1800
Fax: 1-847-967-3915	Fax: 44-1753-224224	Fax: 55-11-3371-2599	Fax: 971-488-62830	Fax: 65-6518-1803

If the products featured will be used in a potentially dangerous and/or hazardous process, your John Crane representative should be consulted prior to their selection and use. In the interest of continuous development, John Crane Companies reserve the right to alter designs and specifications without prior notice. It is dangerous to smoke while handling products made from PTFE. Old and new PTFE products must not be incinerated. ISO 9001 and ISO14001 Certified, details available on request.