

Type 57B/58B/58U

ELASTOMER O-RING SEALS

Technical Specification

- A – Face/Primary Ring
- B – Seat/Mating Ring
- C – O-ring
- D – Anti-X Ring
- E – Snap Ring
- F – Spring
- G – Disc
- H – Retainer

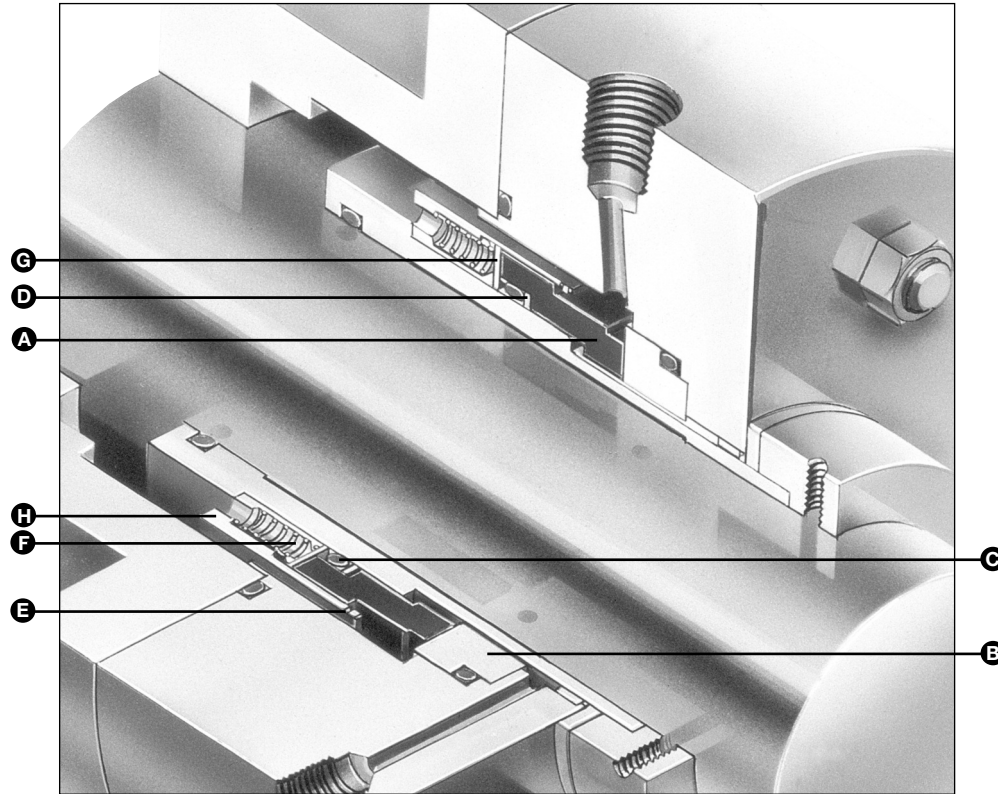

Product Description

The Type 57B and 58B are hydraulically balanced, multi-spring DIN 24960/EN 12756 seals. The Type 58U is an unbalanced multispring DIN24960/EN12756 seal. They are versatile designs using components common to other O-ring and wedge type seals. They allow easy repair, reduce inventory and permit a simple conversion to unbalanced or wedge seals.

- For use in general and high pressure sealing duties, including chemical processing, refinery and petrochemical plants.
- Complies with International Standard ISO 3069, European Standards EN 12756, DIN 24960, and BS 5257: 1975. Also comply with API 610 specifications.

Design Features

- 57B/58B has hydraulically balanced seal face giving lower face loading at high pressure
- Multiple spring arrangement ensures even loading of seal face.
- 57B accepts a maximum axial movement of 0.118"/±3.0mm

Performance Capabilities

- Temperature: –40°F to +500°F/–40°C to +260°C (depending on materials used)
- Pressure: Type 57B/58B: up to 900 psi(g)/62 bar(g)
Type 58U: up to 250 psi(g)/17 bar(g)
- Speed: up to 5000 fpm/25 m/s

Type 57B/58B/58U

ELASTOMER O-RING SEALS

Type 57B/58B Typical Arrangement

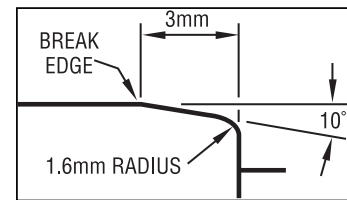
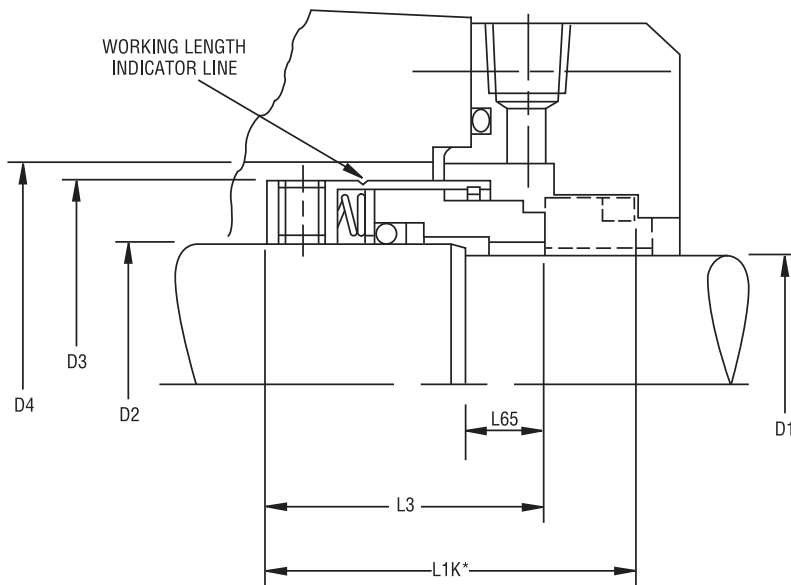

For ease of installation, the lead-in edge of the shaft or sleeve should be chamfered as shown.

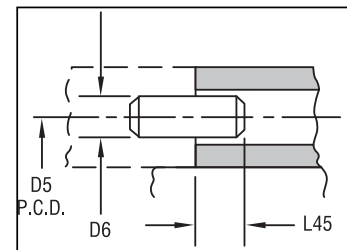

Alternative method of drive. Pin to be press fit in driving collar or impeller, and to engage in seal retainer as shown.

NOTE: Dimensions to DIN24960/ISO 3069

Type 57B and 58B Dimensional Data (mm)

Seal Size (mm)	Seal Size Code	D1h6	D2h6	D3	D4	D5	D6	L1(K)*	L3	L45	L65
14	0140	14	18	32	34	24.5	4.0	42.5	30.5	4.0	6.0
16	0160	16	20	34	36	26.5	4.0	42.5	30.5	4.0	6.0
18	0180	18	22	36	38	28.5	4.0	45.0	31.5	4.0	6.5
20	0200	20	24	38	40	30.5	4.0	45.0	31.5	4.0	6.5
22	0220	22	26	40	42	32.5	4.0	45.0	31.5	4.0	6.5
24	0240	24	28	42	44	34.5	4.0	47.5	34.2	4.0	6.7
25	0250	25	30	44	46	36.5	4.0	47.5	34.5	4.0	7.0
28	0280	28	33	47	49	39.5	4.0	50.0	37.5	4.0	7.5
30	0300	30	35	49	51	41.5	4.0	50.0	38.0	4.0	8.0
32	0320	32	38	54	58	45.0	4.0	50.0	38.0	4.0	8.0
33	0330	33	38	54	58	45.0	4.0	50.0	38.0	4.0	8.0
35	0350	35	40	56	60	47.0	4.0	50.0	38.0	4.0	8.0
38	0380	38	43	59	63	50.0	4.0	52.5	39.5	4.0	10.0
40	0400	40	45	61	65	52.0	4.0	52.5	39.5	4.0	10.0
43	0430	43	48	64	68	55.0	4.0	52.5	39.5	4.0	10.0
45	0450	45	50	66	70	57.0	4.0	52.5	39.5	4.0	10.0
48	0480	48	53	69	73	60.0	4.0	52.5	39.5	4.0	10.0
50	0500	50	55	71	75	62.0	4.0	57.5	44.0	4.0	11.5
53	0530	53	58	78	83	67.5	5.5	57.5	44.0	5.5	11.5
55	0550	55	60	80	85	69.5	5.5	57.5	44.0	5.5	11.5
58	0580	58	63	83	88	72.5	5.5	62.5	49.0	5.5	11.5
60	0600	60	65	85	90	74.5	5.5	62.5	49.0	5.5	11.5
63	0630	63	68	88	93	77.5	5.5	62.5	49.0	5.5	11.5
65	0650	65	70	90	95	79.5	5.5	62.5	49.0	5.5	11.5
70	0700	70	75	95	104	83.5	5.5	70.0	55.5	5.5	13.5
75	0750	75	80	104	109	89.5	5.5	70.0	55.5	5.5	13.5
80	0800	80	85	109	114	94.5	5.5	70.0	55.0	5.5	13.0
85	0850	85	90	114	119	99.5	5.5	75.0	60.0	5.5	13.0
90	0900	90	95	119	124	104.5	5.5	75.0	60.0	5.5	13.0
95	0950	95	100	124	129	109.5	5.5	75.0	60.0	5.5	13.0
100	1000	100	105	129	134	114.5	5.5	75.0	60.0	5.5	13.0

NOTE: Dimensions apply to all seal and seat types unless otherwise indicated.

*When used with a BP, BO, BC and BD seat/mating ring.

Type 57B/58B/58U

ELASTOMER O-RING SEALS

Type 58U Typical Arrangement

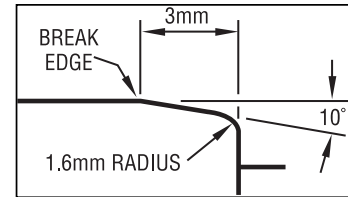
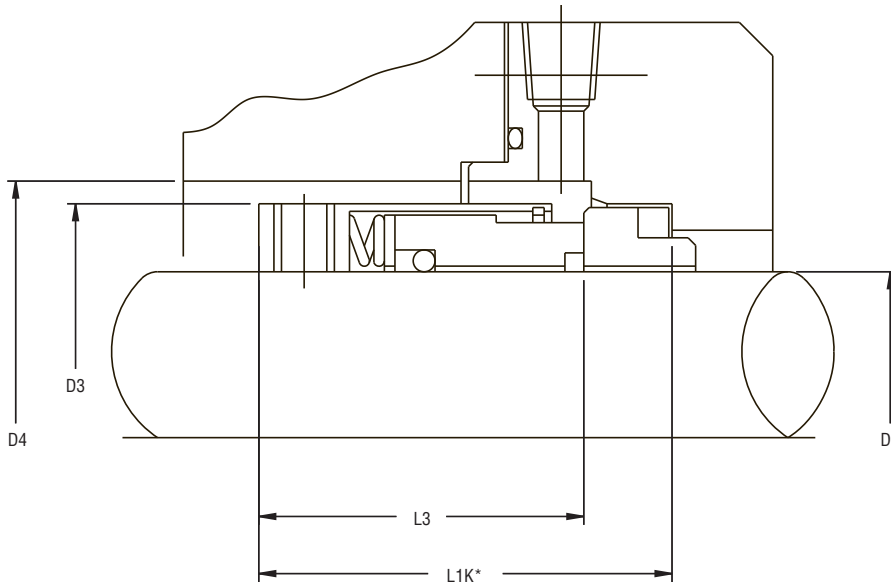

For ease of installation, the lead-in edge of the shaft or sleeve should be chamfered as shown.

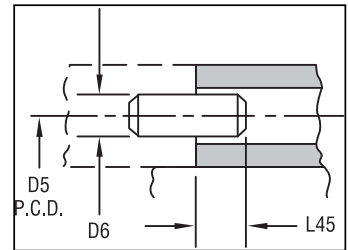

Alternative method of drive. Pin to be press fit in driving collar or impeller, and to engage in seal retainer as shown.

Type 58U Dimensional Data (mm)

Seal Size (mm)	Seal Size Code	D1h6	D3	D4	D5	D6	L1(K)*	L3	L45
14	0140	14	24	26	18.4	2.5	35.0	23.0	4.0
16	0160	16	26	28	20.4	2.5	35.0	23.0	4.0
18	0180	18	32	34	24.5	4.0	37.5	24.0	4.0
20	0200	20	34	36	26.5	4.0	37.5	24.0	4.0
22	0220	22	36	38	28.5	4.0	37.5	24.0	4.0
24	0240	24	38	40	30.5	4.0	40.0	26.7	4.0
25	0250	25	39	41	31.5	4.0	40.0	27.0	4.0
28	0280	28	42	44	34.5	4.0	42.5	30.0	4.0
30	0300	30	44	46	36.5	4.0	42.5	30.0	4.0
32	0320	32	46	48	38.5	4.0	42.5	30.5	4.0
33	0330	33	47	49	39.5	4.0	42.5	30.5	4.0
35	0350	35	49	51	41.5	4.0	42.5	30.5	4.0
38	0380	38	54	58	45.0	4.0	45.0	32.0	4.0
40	0400	40	56	60	47.0	4.0	45.0	32.0	4.0
43	0430	43	59	63	50.0	4.0	45.0	32.0	4.0
45	0450	45	61	65	52.0	4.0	45.0	32.0	4.0
48	0480	48	64	68	55.0	4.0	45.0	32.0	4.0
50	0500	50	66	70	57.0	4.0	47.5	34.0	4.0
53	0530	53	69	73	60.0	4.0	47.5	34.0	4.0
55	0550	55	71	75	62.0	4.0	47.5	34.0	4.0
58	0580	58	78	83	67.5	5.5	52.5	39.0	5.5
60	0600	60	80	85	69.5	5.5	52.5	39.0	5.5
63	0630	63	83	88	72.5	5.5	52.5	39.0	5.5
65	0650	65	85	90	74.5	5.5	52.5	39.0	5.5
68	0680	68	88	93	77.5	5.5	52.5	39.0	5.5
70	0700	70	90	95	79.5	5.5	60.0	45.5	5.5
75	0750	75	95	104	83.5	5.5	60.0	45.5	5.5
80	0800	80	104	109	89.5	5.5	60.0	45.0	5.5
85	0850	85	109	114	94.5	5.5	60.0	45.0	5.5
90	0900	90	114	119	99.5	5.5	65.0	50.0	5.5
95	0950	95	119	124	104.5	5.5	65.0	50.0	5.5
100	1000	100	124	129	109.5	5.5	65.0	50.0	5.5

NOTE: Dimensions apply to all seal and seat types unless otherwise indicated.

*When used with a BP, BO, BC and BD mating ring.

Type 57B/58B/58U

ELASTOMER O-RING SEALS

Basic Pressure Ratings

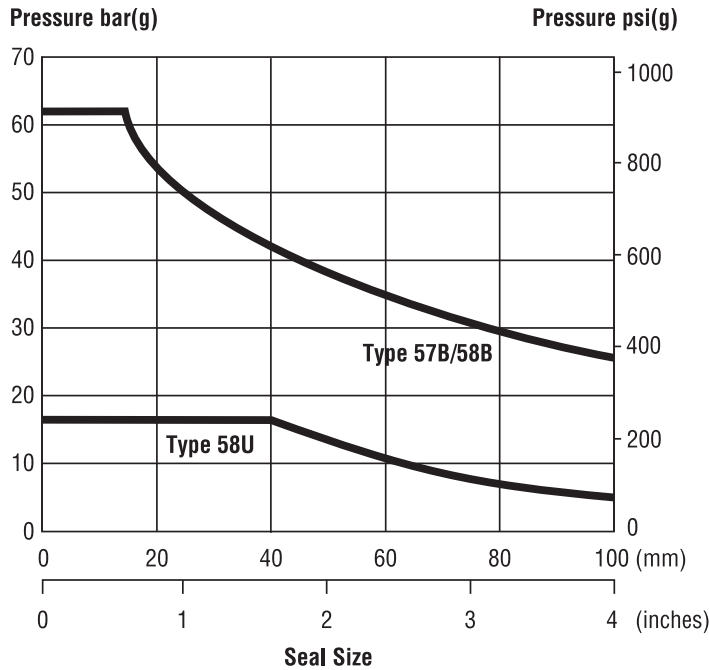

Carbon vs. Silicon Carbide or Tungsten Carbide
in a Lubricating Sealed Fluid at 85°F/30°C at 1,800 rpm

The basic pressure rating is based on a standard seal installed according to the criteria given in this data sheet and according to generally accepted industrial practices. The basic pressure rating assumes stable operation at 1,800 rpm in a clean, cool, lubricating, non-volatile liquid, with an adequate flush rate. When used with the multiplier factors, the basic pressure rating can provide a conservative estimate of the dynamic pressure rating.

Contact John Crane Engineering for process services outside this range and with more detailed application information in order to obtain the actual dynamic pressure rating.

NOTE: For silicon carbide vs. silicon carbide limits, consult John Crane.

Multiplier Factors

	Selection Considerations	Multiplier Factor
Sealed Fluid Lubricity	Petrol/Gasoline, Kerosene, or Better	x 1.00
	Water, Aqueous Solutions (<176°F/80°C)	x 0.75
	Flashing Hydrocarbons*	x 0.60
Sealed Fluid Temperature (For carbon only)	Up to 175°F/80°C	x 1.00
	From 175°F to 250°F/80°C to 120°C	x 0.90
	From 250°F to 355°F/120°C to 180°C	x 0.80
	From 355°F to 500°F/180°C to 260°C	x 0.60
Speed	From 400 to 1,800 rpm	x 1.00
	From 1,800 to 3,600 rpm	x 1,800 rpm/ new speed**
	Above 3,600 or <400 rpm	

Example for Determining Pressure Rating Limits:

Seal: 40mm diameter Type 58B
Product: water
Face materials: carbon vs. silicon carbide
Operating temperature: 140°F/60°C
Speed: 3,000 rpm

* The ratio of sealed pressure to vapor pressure must be greater than 1.5, otherwise consult John Crane. If the specific gravity is less than 0.60, consult John Crane.

**Contact John Crane for more information.

Using the basic pressure rating graph, the maximum pressure would be 900 psi(g)/62 bar(g).

From the multiplier factors chart, apply the multiplier factors for the specific service requirements to determine the maximum operating pressure for the application:

$$900 \text{ psi(g)/62 bar(g)} \times 0.75 \times 1.00 \times \frac{1,800}{3,000} = 405 \text{ psi(g)/27.9 bar(g)}$$

The maximum operating pressure of this 40mm diameter Type 58B seal is 405 psi(g)/27.9 bar(g).

Type 57B/58B/58U

ELASTOMER O-RING SEALS

Hydrostatic Pressure Limits

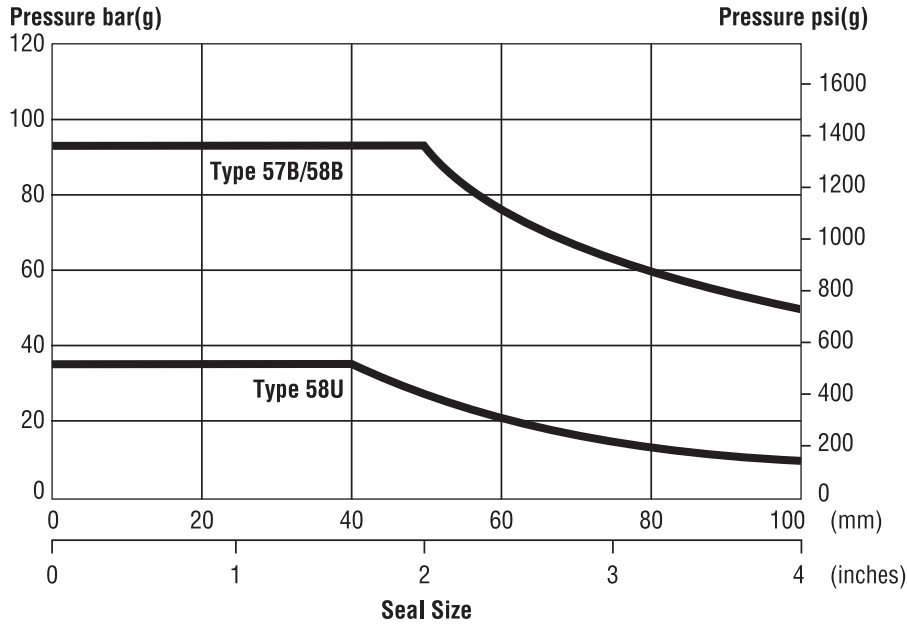

Materials of Construction

SEAL COMPONENTS	MATERIALS	
	Description	Standard
Primary Ring/Face	Resin-Impregnated Carbon Graphite	Sintered Silicon Carbide Antimony Impregnated Carbon Graphite
Snap Ring Set Screw Disc Retainer Springs	316 Stainless Steel	Alloy 400 (Monel [®]) Alloy C-276 (UNS N10276)
Anti-X Ring	Pure PTFE	—
Secondary Seal O-Ring	Nitrile Fluorocarbon Ethylene Propylene	Perfluoroelastomer

Monel is a registered trademark of Inco Alloys International, Inc.

john crane

Type 57B/58B/58U

ELASTOMER O-RING SEALS

Technical Specification

john crane

Type 57B/58B/58U

ELASTOMER O-RING SEALS

Technical Specification

Type 57B/58B/58U

ELASTOMER O-RING SEALS

Technical Specification



North America
 United States of America
 Tel: 1-847-967-2400
 Fax: 1-847-967-3915

Europe
 United Kingdom
 Tel: 44-1753-224000
 Fax: 44-1753-224224

Latin America
 Brazil
 Tel: 55-11-3371-2500
 Fax: 55-11-3371-2599

Middle East & Africa
 United Arab Emirates
 Tel: 971-481-27800
 Fax: 971-488-62830

Asia Pacific
 Singapore
 Tel: 65-6518-1800
 Fax: 65-6518-1803

If the products featured will be used in a potentially dangerous and/or hazardous process, your John Crane representative should be consulted prior to their selection and use. In the interest of continuous development, John Crane Companies reserve the right to alter designs and specifications without prior notice. It is dangerous to smoke while handling products made from PTFE. Old and new PTFE products must not be incinerated. ISO 9001 and ISO14001 Certified, details available on request.