



API PLAN 74 STEAM

SEAL SYSTEMS – STEAM

Installation, Operation & Maintenance Instructions

1. General

1.1 INTRODUCTION

Plan 74 Steam control panel may only be installed, commissioned and maintained by an authorized plant machinery specialist, paying close attention to these instructions and all other relevant regulations. Failure to do this relieves the manufactures from any liability or warranties.

This Instruction Manual is provided to familiarize the user with the Plan 74 Steam control panel arrangement and its use. The instructions must be read and applied whenever work is done on the Plan 74 Steam control panel and must be available to the operating and maintenance personnel.

These instructions will help to avoid danger and increase reliability. They should be used with the appropriate mechanical seal Instruction Manual.

The following important terms and definitions are used in this document.

1.2 EUROPEAN AND/OR UK DECLARATION OF INCORPORATION (MACHINERY DIRECTIVE 2006/42/EC, AND UK SI 2008 NO. 1597)

If appropriate this is attached.

1.3 EUROPEAN DECLARATION OF CONFORMITY (PRESSURE EQUIPMENT DIRECTIVE, 2014/68/EU)

This directive is not applicable to Plan 74 Steam control panel.

1.4 EUROPEAN AND/OR UK DECLARATION OF CONFORMITY (ATEX 2014/34/EU, AND EQUIPMENT AND UK SI 2016 NO. 1107)

These instructions are intended for use with system operating in Equipment Group II, category 2GD.

The Declaration covers the complete seal and system and the Maximum Surface temperature is recorded in the Mechanical Seal Instruction Manual.

If appropriate this is attached.

2. Safety and environment

The safety notes refer to the system supplied. They can never be exclusive, and must be used in connection with the relevant safety regulations for the machine, auxiliary equipment, plant and sealed product.

2.1 WARNING SYMBOLS

The following symbols are used in this instruction manual to highlight information of particular importance:



Danger
Mandatory instructions designed to prevent personal injury or extensive damage.



Warning of electric current

ATTENTION Special instructions or information to avoid damage to the system or its surroundings.

NOTE Information for easy installation and efficient operation.



Environmental note

Compliance is required with any additional warning signs affixed to the system.

2.2 SAFETY INSTRUCTIONS



ATTENTION

Every working practice that compromises personal safety is to be avoided. All safety requirements in this document must be strictly adhered to.

In the event of an operating problem, the machinery must be switched off immediately and made safe! Problems must be solved promptly.

Ensure suitable protective clothing is used when maintaining the system.

Plan 74 Steam control panel systems are commonly used with dual mechanical seal configurations to reduce the hazard potential from flammable, explosive, toxic or lethal process fluids. The intermediate, protective steam barrier, in certain failure modes, may risk being contaminated by the process fluid. During any maintenance operation operators must thus assume they will be exposed to the liquid or gaseous properties of the process fluid and have suitable protective gloves, clothing, respirators and equipment.

Particular note must be taken of the relevant guidelines for the electrical installations.

A slight leakage will occur during normal seal operation. Depending on the duty, this leakage can appear as a gas, a liquid or a solid. In case of a worn or defective seal the leakage will increase. The leakage may be hazardous or toxic, and a safe collection system is required.

Surface temperatures above 60°C/140°F should be protected against accidental contact. The panels may be mounted in a protective enclosure for this purpose.

The equipment sealed by this seal system must be operated within its recommended design limits.

Compounds containing PTFE, fluorocarbons and perfluoroelastomers should never be burnt as the fumes and residues are highly toxic. If this accidentally occurs protective equipment should be worn as hydrofluoric acid may be present

Additional equipment/flanges/joint seals used within the system are to be rated for the appropriate electrical and pressure requirements and are to be chemically compatible with the buffer gas and process fluid.

- During venting or draining of the buffer region it should be piped to a vent or reservoir where it can be safely contained or disposed.
- All above according to the local legislation.
- For further information and safe operating limits contact John Crane
- All periodical maintenance checks have to be in accordance with local legislation and rules.

All welding or cutting operations are forbidden without permission from John Crane.

If you are in any doubt please contact your local John Crane office for further information before proceeding.



API PLAN 74 STEAM

SEAL SYSTEMS – STEAM

Installation, Operation & Maintenance Instructions

2.3 ENVIRONMENTAL ASPECTS

2.3.1 COMPANY POLICY EXTRACT

"It is the policy of John Crane to manage its business activities in an environmentally responsible manner, comply with all relevant laws and regulations, prevent pollution, and continually improve its environmental performance, certification to the latest issue of ISO 14001 ensures compliance."



John Crane adopts the '**Design For the Environment**' (DFE) principle in making this product. Using this product will benefit the environment **directly** by:

- **Reducing waste** of precious resources through decreasing the risk of leakage and minimizing energy consumption.
- **Preventing pollution** through controlling harmful emissions to the atmosphere and ground contamination.
- **Preserving valuable materials** through the use of high quality durable materials.

2.3.2 RECYCLING

PRODUCT REFURBISHMENT

This product has been designed for long life.

DISPOSAL

When the product is considered to be beyond economical repair and potential reuse, it should be disposed of by **environmentally beneficial** means. The product can be disassembled with ease.

SCRAPPED COMPONENTS

These should be handled with extra care due to possible contamination. They should be **recycled** through **local** industrial recycling plants.

PACKAGING

All packaging materials used are made from **recyclable**, environmentally friendly materials.

When in doubt or for further information and advice on this subject, please consult **John Crane**.

3. Transportation and storage

Transport and store the system where possible in its original packaging.

It is necessary to protect and preserve the integrity of the equipment between shipment and installation/start-up at site. This is particularly important when extended periods of storage are envisaged.

Plan 74 systems may be shipped first to the rotating equipment vendor to be mounted on the rotating equipment baseplate complete with the connecting pipework. In this event follow the instructions as given in the rotating equipment IOM.

Plan 74 systems, which are to be mounted off the rotating equipment baseplate, shall be shipped directly to site and shall be packed in suitable crates or cases to protect them from damage during shipment. All openings to the system are closed and sealed for shipping. In this event follow the following instructions.

On arrival at site and before unloading for storage, a visual inspection of the crate/case should be carried out for signs of damage during shipment. In the event of any damage the crate/case must be opened, and the contents thoroughly examined for signs of equipment damage. All bolts and threaded connections should be checked for signs that they have come loose during transport. If any seals are broken, then the system is assumed to be contaminated and shall be cleaned accordingly. All loose connections or bolts should be correctly tightened to eliminate any loosening which has occurred during transportation or as part of the cleaning process.

If the parts are considered acceptable with no visual signs of damage, the crate/case should be properly closed again prior to storage.

After checking for shipment damage, the following recommendations should be undertaken to prevent deterioration arising from long term storage.

- Plan 74 Steam control panel system should be replaced in their original packaging and if possible the crate/case should be stored away from direct sunlight, in a well-ventilated building with a hard floor.
- Temperature control is not normally necessary, but large temperature fluctuations (>40°C/72°F) should be avoided.
- If stored outdoors, it is recommended that the crate/case be placed on square timber bearers resting on a concrete or similar hard surface.
- The crate/case must then be wrapped with waterproof tarpaulin to prevent ingress of water and dirt.
- Loose components or accessories in the case should be stored as above, after proper itemization.
- A weekly visual external inspection of the protection and preservation should be undertaken and any deficiencies noticed should be corrected without delay.
- The system must be stored far from backwater to avoid the MIC phenomenon (microbial corrosion).

NOTE Should water, condensation, sand, dirt or other contaminant enter the system, through package/tarpaulin damage or improperly positioned covers, the cause of the problem must be eliminated and the equipment thoroughly dried and cleaned before re-storing.

If used system parts are to be transported to the manufacturer or a third party they have to be cleaned, decontaminated and require safe handling instructions externally attached.

ATTENTION The system normally does not require any preservatives; it is resistant against most environmental conditions. Ensure preservatives and cleaning agents do not affect the elastomers.



API PLAN 74 STEAM

SEAL SYSTEMS – STEAM

Installation, Operation & Maintenance Instructions

4. Description of the system

4.1 FUNCTION OF THE SYSTEM

Where rotating machines (pumps, fans or mixers) work with hazardous fluids, it is common practice to install double mechanical seals which prevent leakage of the process fluid escaping into the surrounding environment.

Non contacting dry running gas seals are frequently used for this purpose.

The barrier fluid is clean dry steam, constantly supplied to the mechanical seal inter-space from a reliable source at a pressure greater than 2 bar (30 psi) above the product pressure. The Plan 74 Steam control panel is specifically designed for using steam as this barrier gas. The Plan 74 Steam control panel must maintain the correct pressure for the steam, and condition it to separate any condensate before delivery to the seal, and prevent condensate forming within the seal.

The Plan 74 Steam control panel consists of two panels, one upstream of the mechanical seal, and one downstream of the mechanical seal. The upstream panel includes a separating chamber to ensure that the steam supply to the seal is free of condensate particulates. A steam trap is present at the lowest point of the panel to release any condensate from the separation chamber. A check-valve between the upstream panel and the seal prevents contamination of the steam supply in an upset condition. Seal operating pressure is set by adjusting the control panel regulator in conjunction with the system pressure transmitter LCD read-out, and/or pressure gauges if fitted.

The downstream panel serves the purpose of allowing any condensate which forms in the seal to be routed to a steam trap to be released. The downstream panel is normally the location for the pressure indicating transmitter, and an additional pressure gauge.

Steam flows are visually monitored using the panel mounted pressure transmitter to provide a common signal indicating loss of gas supply pressure.

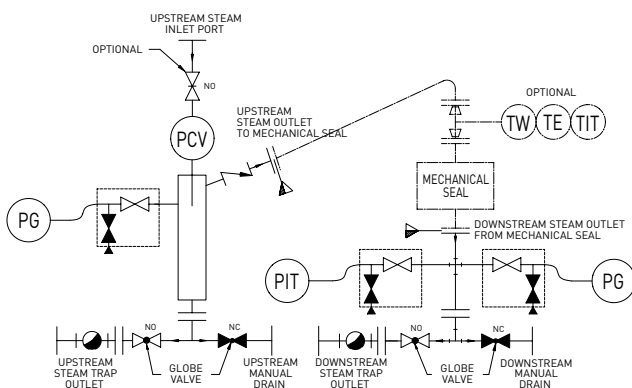

4.2 INSTRUMENTATION AND FITTINGS

The system is usually supplied with the following:

- Upstream steam supply inlet (flanged or threaded)
- Upstream panel outlet to seal (flanged or threaded)
- Upstream steam trap outlet (flanged or threaded)

- Upstream manual steam drain (flanged or threaded)
- Upstream pressure gauge (PG)
- Downstream steam inlet from seal (flanged or threaded)
- Alternative downstream steam inlet from seal - blanked (flanged or threaded)
- Downstream steam trap outlet (flanged or threaded)
- Downstream manual steam drain (flanged or threaded)
- Downstream pressure gauge (PG)
- Downstream pressure indicating transmitter (PIT)

And, upon request with the following options:

- Pressure switch (PS) instead of a PIT
- Temperature indicating transmitter (TIT) mounted on pipe extension. Supplied loose

5. Installation and assembly

5.1 BEFORE INSTALLATION

Prior to installation ensure that internally all connecting pipe work has been thoroughly cleaned. Remove protection caps from pipes and connections. Check all fittings/connections for damage replacing if necessary.

5.2 CONTROL PANEL MOUNTING

Refer to the appropriate arrangement drawing for mounting details.

It is recommended that piping between the each panel and the mechanical seal should be kept below 2 meters/72 inches in length wherever possible. If this length is exceeded consideration should be given to increased frictional losses and if necessary allowances must be made when setting the seal pressure.

The downstream panel must be mounted so that the steam inlet from the seal, and the downstream steam traps are below the mechanical seal, and the interconnecting pipework to the downstream panel must allow condensate to gravity drain to the steam traps.

With the steam supply isolated, connect the steam supply piping to the inlet connection on the upstream panel, connect the upstream panel outlet connection to the mechanical seal gas barrier in (GBI) connection. If a TIT is supplied, this must be mounted between the upstream outlet connection and the mechanical seal. Connect the mechanical seal gas barrier out (GBO) connection to the inlet connection of the downstream panel. Do not open steam supply at this time.

Route the outlets to the steam traps and vent valve to a safe location to expel steam and condensate.



It is recommended that all pipework be lagged, in order to maintain the steam temperature, and to protect personnel from accidental contact. Lagging should be applied around all pipework and components during installation and assembly, leaving room to read instruments and operative valves. If a protective enclosure is supplied, this should also be fitted before the system is brought up to temperature.



API PLAN 74 STEAM

SEAL SYSTEMS – STEAM

Installation, Operation & Maintenance Instructions

5.3 ELECTRICAL CONNECTIONS



Only authorized and qualified personnel are permitted to carry out work on electrical systems. International and local safety regulations must be followed in all cases.

Before connecting cables, check the electrical data on the name plate matches the available power supply and complies with the area hazard classification.

Refer to the diagrams in the terminal housing and the supplier's instruction manual for wiring instructions. Connect the electrical component using flexible conduit or armoured cable to assist removal of the component for maintenance purposes.

If passive switching elements are installed in potentially explosive areas you should add suitable protective devices, following the pertinent rules.

5.4 LEAK CHECK

During transit, tube fittings may work loose, check all fittings/connections for tightness. First checking that the buffer gas supply pressure is within the limits of the control panel slowly open the buffer gas supply line isolation valves allowing the control panel to pressurize.

Using a suitable leak testing liquid, check all joints and if necessary, rectify any leaks found.

6. Commissioning and Decommissioning

6.1 COMMISSIONING

Before starting the machine (pump or mixer) carry out the following operations:

ATTENTION Before commencing the start-up procedure, review and become familiar with all the available instructions concerning the equipment, especially the safety warnings.

A. Set the operating pressure to the 'operating pressure' on the nameplate (typically 2 barg/30 psig greater than the process pressure) by adjusting the regulator valve until the correct pressure is shown on the pressure transmitter LCD (and/or pressure gauge if fitted). Turning the regulator adjuster clockwise increases pressure and counter-clockwise decreases pressure.

B. Check that the pressure transmitter/switch set points are correctly adjusted to suit the duty: Refer to the table below.

Alarm Name	Instrument	Set Point	Notes
Low Pressure /Shutdown Required	Pressure Indicating Transmitter (PIT) or Pressure Switch (PS)	If barrier pressure drops below the operating pressure on the nameplate	REQUIRED
High Flow Alert	Flow Indicating Transmitter (FIT) or Flow Switch (FS)	If barrier flow rises significantly above the value indicated on the nameplate	RECOMMENDED

NOTE High flow alarms are not recommended on Plan 74 Steam control panels with steam barrier gas, as the flow includes both the consumption of the mechanical seal, condensation of the steam and the steam/condensate released by the steam traps, therefore flow monitoring is an unreliable method to monitor performance of the mechanical seal.

C. Slowly open the drain valve and allow steam to flow through the system.

D. Close the drain valve once the surface temperature of the piping reaches 120°C/250°F

E. Verify the operating pressure is set at the correct pressure

F. Start the machine.

G. During initial start-up, it is recommended that the steam pressure is regularly monitored for correct operation. Fine tune pressure setting if necessary.

6.2 NORMAL RUNNING

The equipment shall be kept clean and free from debris to allow ease of access and reading of the instrumentation. Care should be taken to prevent damage to the system from accidental knocks and/or exposure to excessive sources or heat. Disconnection of any part of the system should not be undertaken without the appropriate authorization and until all pressure has been completely discharged and system allowed to cool. All joints broken for maintenance should be plugged off to prevent ingress of dirt.

During normal operation the only attention required is to monitor the barrier steam pressure, and operation of the steam traps. Periodic visual checking (at least every 48 hours) of the pressure within the system is recommended.

6.3 DECOMMISSIONING



Work on the seal or system must only be carried out when the machine is stationary, and secured against any unforeseen start-up. Isolation from connections to pressurization sources must be carried out.

Before carrying out any work on the seal or system, the equipment must be shut down and the buffer region must be fully depressurized. Once this has been done the buffer gas supply to the panel can be isolated.

Do not isolate the steam barrier supply before the pump is made safe and the temperature has reduced to levels safe for handling.

Once the steam barrier supply is isolated carefully vent any residual pressure from the Plan 74 Steam control panel and interconnecting pipe work and drain any liquids before carrying out any maintenance. If the pump/panel is to be removed cover any open tubing fittings/connections to prevent contamination.

NOTE It is recommended that a pressure test is carried out on the system after any repair and before operation on the equipment.



API PLAN 74 STEAM

SEAL SYSTEMS – STEAM

Installation, Operation & Maintenance Instructions

7. Maintenance

7.1 Routine maintenance

Check the following as part of regular site walk-around checks for trouble-free operation:

- Check the condition of the steam traps (see Section 7.2).
- Barrier pressure. Compare with the operating pressure on the nameplate.
- Condition of alarm signals (see Section 7.3).

7.2 Steam traps

Steam traps have a finite life, the duration of which is determined by the quantity of condensate to be released from the system. If a steam trap has reached the end of its life, it will no longer operate, and condensate will begin to build up in the system.

To check the operation, visually check for signs that condensate is being released, and then slightly crack open the manual steam drain valve. If condensate is released, this indicates that the steam trap is no longer operating and liquid is building up inside the system. The steam trap(s) should then be replaced at the earliest opportunity.



While operating the manual drain, the system is pressurized with high temperature steam. Correct PPE must be worn, the drain must be directed to a safe location for the release of hot steam, and the valve should be opened by the absolute minimum to reduce the quantity of steam released, for personnel safety, and to prevent a loss of pressure in the Plan 74 Steam control panel.

It is recommended that the steam traps are checked after the first month of operation and thereafter at monthly intervals.

Irrespective of visual condition, it is recommended that the steam traps are replaced annually.

7.3 Signals and alarms

The instrumentation on the system has the specific purpose of signalling eventual malfunction of the mechanical seals. Possible alarm signals indicating a malfunction are as shown in Table 2.

Effect	Instrument	Action	Cause
Falling Pressure	Pressure Gauge (PG) or Pressure Indicating Transmitter (PIT)	A	C to E
Low Pressure/ Shutdown Required	Pressure Indicating Transmitter (PIT) or Pressure Switch (PS)	B	C to E

Actions

A	Investigate cause and monitor to ensure values do not breach safe limits
B	Shut down machine to prevent damage or loss of containment

Causes

C	Excessive leakage across the inboard seal or outboard seal
D	Pipe work/joint failure
E	Drop in the barrier gas supply pressure/flow

The signal from the pressure transmitter can be used either:

- LOCALLY (with a Klaxon and/or beacon)
- REMOTELY (in the control room)

Consult the specific instrument manufacturers manual should there be a malfunction.

If necessary for safety, the alarm signals could be used as a trip function.

7.4 Instrument maintenance

All instruments require regular calibration, following local processes and regulations. See the supplier's instruction manual for and additional instructions for maintenance of electrical instruments.

7.5 Spare parts

Spare parts must conform to the established technical specifications of the manufacturer. This is guaranteed with John Crane spare parts.

You are advised to stock the most important wear parts on site.

The following data is necessary for spare part orders:

- John Crane code/part number
- John Crane order/ref no.
- Part description
- Quantity

7.6 Annual maintenance checks

Disconnection shall be made by plant person in charge of authorization.

Before any maintenance operation the system, the machine must be stopped and depressurized, the barrier pressure must be fully discharged, and the equipment allowed to cool to ambient temperature.

A suitable container should be available to contain any liquid drained from the barrier system.

All parts requiring maintenance must be thoroughly decontaminated prior to any work commencing.

All joints should be checked for tightness and signs of steam barrier leakage. If present, all flange joints should be checked for tightness and, if necessary, gaskets changed using replacements available from John Crane.



API PLAN 74 STEAM

SEAL SYSTEMS – STEAM

Installation, Operation & Maintenance Instructions

8. Accompanying Documents

Installation Drawing (job specific) or Typical Drawing and Operational Data Sheet.

A name and data plate is fitted to each Plan 74 Steam control panel. It contains references and part numbers which must be quoted in any communication.

For replacement parts please contact your local John Crane office, quoting the system code number.

9. Cold Environments

For environments with low ambient temperatures, winterization features may be added to the Plan 74 Steam control panel. These may include:

- The panel may be supplied mounted in a heated enclosure. The heating element requires electrical connection as part of the installation and assembly procedure (see Section 6.2).
- Heat tracing and/or insulation may be required to maintain the temperature of the steam in the Plan 74 Steam control panel. This heat tracing and/or insulation may be supplied with the Plan 74 Steam control panel, or may be applied on site around all pipework and components during installation and assembly, leaving room to read instruments and operative valves.
- Heat tracing is likely to only be required during start-up or standby conditions.
- Care must be taken during commissioning and operation, that the Plan 74 Steam control panel is brought up to operating temperature before the machine is started, and the correct temperature is maintained throughout operation.



North America United States of America Tel: 1-847-967-2400	Europe United Kingdom Tel: 44-1753-224000	Latin America Brazil Tel: 55-11-3371-2500	Middle East & Africa United Arab Emirates Tel: 971-481-27800	Asia Pacific Singapore Tel: 65-6518-1800
---	--	--	---	---

If the products featured will be used in a potentially dangerous and/or hazardous process, your John Crane representative should be consulted prior to their selection and use. In the interest of continuous development, John Crane Companies reserve the right to alter designs and specifications without prior notice. It is dangerous to smoke while handling products made from PTFE. Old and new PTFE products must not be incinerated. ISO 9001 and ISO14001 Certified, details available on request.