



# API PLAN 74

## SEAL SYSTEMS

### Installation, Operation & Maintenance Instructions

## 1. General

### 1.1 INTRODUCTION

Plan 74 may only be installed, commissioned and maintained by an authorized plant machinery specialist, paying close attention to these instructions and all other relevant regulations. Failure to do this relieves the manufactures from any liability or warranties.

This Instruction Manual is provided to familiarize the user with the Plan 74 arrangement and its use. The instructions must be read and applied whenever work is done on the Plan 74, and must be available to operating and maintenance personnel.

These instructions will help to avoid danger and increase reliability. They should be used with the appropriate mechanical seal Instruction Manual.

The following important terms and definitions are used in this document.

### 1.2 EUROPEAN AND/OR UK DECLARATION OF INCORPORATION (MACHINERY DIRECTIVE 2006/42/EC, AND UK SI 2008 NO. 1597)

If appropriate this is attached.

### 1.3 EUROPEAN DECLARATION OF CONFORMITY (PRESSURE EQUIPMENT DIRECTIVE, 2014/68/EU)

This directive is not applicable to Plan 74.

### 1.4 EUROPEAN AND/OR UK DECLARATION OF CONFORMITY (ATEX 2014/34/EU, AND EQUIPMENT AND UK SI 2016 NO. 1107)

These instructions are intended for use with system operating in Equipment Group II, category 2GD.

The Declaration covers the complete seal and system and the maximum surface temperature is recorded in the Mechanical Seal Instruction Manual.

If appropriate this is attached.

## 2. Safety and environment

The safety notes refer to the system supplied. They can never be exclusive, and must be used in connection with the relevant safety regulations for the machine, auxiliary equipment, plant and sealed product.

### 2.1 WARNING SYMBOLS

The following symbols are used in this instruction manual to highlight information of particular importance:



**Danger**  
Mandatory instructions designed to prevent personal injury or extensive damage.



**Warning of electric current**

**ATTENTION** Special instructions or information to avoid damage to the system or its surroundings.

**NOTE** Information for easy installation and efficient operation.



**Environmental note**

Compliance is required with any additional warning signs affixed to the system.

**ATTENTION** Special instructions or information to avoid damage to the system or its surroundings.

**NOTE** Information for easy installation and efficient operation.

### 2.2 SAFETY INSTRUCTIONS



#### ATTENTION

Every working practice that compromises personal safety is to be avoided. All safety requirements in this document must be strictly adhered to.

In the event of an operating problem, the machinery must be switched off immediately and made safe! Problems must be solved promptly.

Ensure suitable protective clothing is used when maintaining the system.

Plan 74 systems are commonly used with dual mechanical seal configurations to reduce the hazard potential from flammable, explosive, toxic or lethal process fluids. The intermediate, protective barrier gas, in certain failure modes, may risk being contaminated by the process fluid. During any maintenance operation operators must thus assume they will be exposed to the liquid or gaseous properties of the process fluid and have suitable protective gloves, clothing, respirators and equipment.

Particular note must be taken of the relevant guidelines for the electrical installations.

A slight mechanical seal leakage will occur during normal seal operation. Depending on the duty, this leakage can appear as a gas, a liquid or a solid. In case of a worn or defective seal the leakage will increase. The leakage may be hazardous or toxic, and a safe collection system is required.

Surface temperatures above 60°C/140°F should be protected against accidental contact.

The equipment sealed by this seal system must be operated within its recommended design limits.

Compounds containing PTFE, fluorocarbons and perfluoroelastomers should never be burnt as the fumes and residues are highly toxic. If this accidentally occurs protective equipment should be worn as hydrofluoric acid may be present.

Additional equipment/flanges/joint seals used within the system are to be rated for the appropriate electrical and pressure requirements and are to be chemically compatible with the barrier gas and process fluid.

- During venting or draining of the buffer region it should be piped to a vent or reservoir where it can be safely contained or disposed.
- All above according to the local legislation.
- For further information and safe operating limits contact John Crane.
- All periodical maintenance checks have to be in accordance with local legislation and rules.

All welding or cutting operations are forbidden without permission from John Crane.

If you are in any doubt please contact your local John Crane office for further information before proceeding.



# API PLAN 74

## SEAL SYSTEMS

### Installation, Operation & Maintenance Instructions

## 2.3 ENVIRONMENTAL ASPECTS

### 2.3.1 COMPANY POLICY EXTRACT

*"It is the policy of John Crane to manage its business activities in an environmentally responsible manner, comply with all relevant laws and regulations, prevent pollution, and continually improve its environmental performance, certification to the latest issue of ISO 14001 ensures compliance."*



John Crane adopts the '**Design For the Environment**' (DFE) principle in making this product. Using this product will benefit the environment **directly** by:

- **Reducing waste** of precious resources through decreasing the risk of leakage and minimizing energy consumption.
- **Preventing pollution** through controlling harmful emissions to the atmosphere and ground contamination.
- **Preserving valuable materials** through the use of high quality durable materials.

### 2.3.2 RECYCLING

#### PRODUCT REFURBISHMENT

This product has been designed for long life.

#### DISPOSAL

When the product is considered to be beyond economical repair and potential reuse, it should be disposed of by **environmentally beneficial** means. The product can be disassembled with ease.

#### SCRAPPED COMPONENTS

These should be handled with extra care due to possible contamination. They should be **recycled** through **local** industrial recycling plants.

#### PACKAGING

All packaging materials used are made from **recyclable**, environmentally friendly materials.

When in doubt or for further information and advice on this subject, please consult **John Crane**.

## 3. Transportation and storage

Transport and store the system where possible in its original packaging.

It is necessary to protect and preserve the integrity of the equipment between shipment and installation/start-up at site. This is particularly important when extended periods of storage are envisaged.

Plan 74 systems may be shipped first to the rotating equipment vendor to be mounted on the rotating equipment baseplate complete with the connecting pipework. In this event follow the instructions as given in the rotating equipment IOM.

Plan 74 systems, which are to be mounted off the rotating equipment baseplate, shall be shipped directly to site and shall be packed in suitable crates or cases to protect them from damage during shipment. All openings to the system are closed and sealed for shipping. In this event follow the following instructions.

On arrival at site and before unloading for storage, a visual inspection of the crate/case should be carried out for signs of damage during shipment. In the event of any damage the crate/case must be opened, and the contents thoroughly examined for signs of equipment damage. All bolts and threaded connections should be checked for signs that they have come loose during transport. If any seals are broken, then the system is assumed to be contaminated and shall be cleaned accordingly. All loose connections or bolts should be correctly tightened to eliminate any loosening which has occurred during transportation or as part of the cleaning process.

If the parts are considered acceptable with no visual signs of damage, the crate/case should be properly closed again prior to storage.

After checking for shipment damage, the following recommendations should be undertaken to prevent deterioration arising from long term storage.

- Plan 74 system should be replaced in their original packaging and if possible the crate/case should be stored away from direct sunlight, in a well-ventilated building with a hard floor.
- Temperature control is not normally necessary, but large temperature fluctuations (>40°C/72°F) should be avoided.
- If stored outdoors, it is recommended that the crate/case be placed on square timber bearers resting on a concrete or similar hard surface.
- The crate/case must then be wrapped with waterproof tarpaulin to prevent ingress of water and dirt.
- Loose components or accessories in the case should be stored as above, after proper itemization.
- A weekly visual external inspection of the protection and preservation should be undertaken and any deficiencies noticed should be corrected without delay.
- The system must be stored far from backwater to avoid the MIC phenomenon (microbial corrosion).

**NOTE** Should water, condensation, sand, dirt or other contaminant enter the system, through package/tarpaulin damage or improperly positioned covers, the cause of the problem must be eliminated and the equipment thoroughly dried and cleaned before re-storing

If used system parts are to be transported to the manufacturer or a third party they have to be cleaned, decontaminated and require safe handling instructions externally attached.

**ATTENTION** The system normally does not require any preservatives; it is resistant against most environmental conditions. Ensure preservatives and cleaning agents do not affect the elastomers.



# API PLAN 74

## SEAL SYSTEMS

Installation, Operation & Maintenance Instructions

### 4. Description of the system

#### 4.1 FUNCTION OF THE SYSTEM

Where rotating machines (pumps, fans or mixers) work with hazardous fluids, it is common practice to install double mechanical seals which prevent leakage of the process fluid escaping into the surrounding environment.

Non contacting dry running gas seals are frequently used for this purpose.

The barrier fluid is a clean dry gas, normally Nitrogen, constantly supplied to the mechanical seal inter-space from a reliable source at a pressure greater than 2 bar (30 psi) above the product pressure.

The Plan 74 control panel includes a coalescing filter to ensure that the final barrier gas supply to the seal is free of particulates and moisture. Seal operating pressure is set by adjusting the control Plan 74 control panel regulator in conjunction with the system pressure transmitter LCD read-out (and/or pressure gauge if fitted).

Gas flows are visually monitored using the panel mounted flow transmitter and pressure transmitter to provide a common signal indicating either excess gas consumption and/or loss of gas supply pressure.

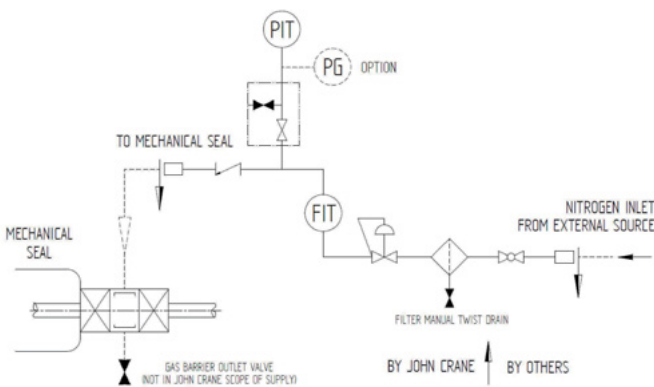

#### 4.2 INSTRUMENTATION AND FITTINGS

The system is usually supplied with the following:

- Barrier gas supply inlet (flanged or threaded)
- Panel outlet to seal (flanged or threaded)
- Pressure indicating transmitter (PIT)
- Flow indicating transmitter (FIT)

And, upon request with the following options:

- Pressure gauge (PG)
- Pressure switch (PS) instead of a PIT
- Flow indicator (FI) instead of FIT
- Flow switch (FS) with the flow indicator

### 5. Installation and Assembly

#### 5.1 BEFORE INSTALLATION

Prior to installation ensure that internally all connecting pipe work has been thoroughly cleaned. Remove protection caps from pipes and connections. Check all fittings/connections for damage replacing if necessary.

#### 5.2 CONTROL PANEL MOUNTING

Refer to the appropriate arrangement drawing for mounting details.

It is recommended that piping between the Plan 74 control panel and the mechanical seal should be kept below 2 metres (72 inches) in length wherever possible. If this length is exceeded, consideration should be given to increased frictional losses and, if necessary, allowances must be made when setting the seal pressure.

**It is advisable to install a vent connection in the interconnecting pipe work close to the seal chamber.**

With the gas supply isolated, connect the barrier gas supply piping to the inlet connection on the Plan 74 control panel and connect the panel outlet connection to the mechanical seal gas barrier in (GBI) connection. Do not open gas supply at this time.

#### 5.3 ELECTRICAL CONNECTIONS



**Only authorized and qualified personnel are permitted to carry out work on electrical systems. International and local safety regulations must be followed in all cases.**

Before connecting cables, check the electrical data on the name plate matches the available power supply and complies with the area hazard classification.

Refer to the diagrams in the terminal housing and the supplier's instruction manual for wiring instructions. Connect the electrical component using flexible conduit or armoured cable to assist removal of the component for maintenance purposes.

If passive switching elements are installed in potentially explosive areas you should add suitable protective devices, following the pertinent rules.

#### 5.4 LEAK CHECK

During transit, tube fittings may work loose, check all fittings/connections for tightness. First checking that the barrier gas supply pressure is within the limits of the Plan 74 control panel, slowly open the barrier gas supply line isolation valve allowing the control panel to pressurize.

Using a suitable leak testing liquid check all joints and if necessary, rectify any leaks found.



# API PLAN 74

## SEAL SYSTEMS

### Installation, Operation & Maintenance Instructions

## 6. Commissioning and Decommissioning

### 6.1 COMMISSIONING

Before starting the machine (pump or mixer) carry out the following operations:

- ATTENTION** Before commencing the start-up procedure, review and become familiar with all the available instructions concerning the equipment, especially the safety warnings.
- Set the operating pressure to the 'operating pressure' on the nameplate (typically 2 barg/30 psig greater than the process pressure) by adjusting the regulator valve until the correct pressure is shown on the pressure transmitter LCD (or pressure gauge if fitted). Turning the regulator adjuster clockwise increases pressure and counter-clockwise decreases pressure.
  - Purge the system of air by cracking open the vent connection (if fitted) or by carefully cracking open the fitting at the seal and allowing barrier gas to escape. After 10-15 seconds flow retighten the vent/fitting.
  - Recheck the operating pressure on the pressure gauge (if fitted) or pressure transmitter LCD and fine tune if necessary.
  - Check that the pressure transmitter/switch and flow transmitter/switch set points are correctly adjusted to suit the duty: Refer to the table below.

TABLE 1. Alarm Signals

Alarm Name	Instrument	Set Point	Notes
Low Pressure /Shutdown Required	Pressure Indicating Transmitter (PIT) or Pressure Switch (PS)	If barrier pressure drops below the operating pressure on the nameplate	REQUIRED
High Flow Alert	Flow Indicating Transmitter (FIT) or Flow Switch (FS)	If barrier flow rises significantly above the value indicated on the nameplate	RECOMMENDED

**NOTE** High flow alarms are recommended as indicators of significant deviations from normal running conditions; some fluctuation is expected during operation. The alarm value on the nameplate is normally several times larger than the normal running value, and is set based on the limits of barrier gas that can safely be injected into the machine.

- Start the machine
- During initial start-up it is recommended that the gas pressure/flow is regularly monitored for correct operation. Fine tune pressure setting if necessary.

### 6.2 NORMAL RUNNING

The equipment shall be kept clean and free from debris to allow ease of access and reading of the instrumentation. Care should be taken to prevent damage to the system from accidental knocks and/or exposure

to excessive sources or heat. Disconnection of any part of the system should not be undertaken without the appropriate authorization and until all pressure has been completely discharged and system allowed to cool. All joints broken for maintenance should be plugged off to prevent ingress of dirt.

During normal operation the only attention required is to monitor the barrier gas flow. Periodic visual checking (at least every 48 hours) of the pressure/flow within the system is recommended.

If the consumption rate of the barrier gas is low, this can result in a phenomenon where the check valve closes fully and does not open again until the pressure difference across the valve exceeds its cracking pressure. This results in sudden increases in flow when the valve opens, and then zero flow once it closes again, which will appear as pulsations in the flow indicator/indicating transmitter. This is normal and does not indicate a failure mode for the equipment. If the pulsations are large enough to trigger high flow alarms, these alarm values may need to be raised to avoid nuisance alarms.

### 6.3 DECOMMISSIONING



**Work on the seal or system must only be carried out when the machine is stationary, depressurized, and secured against any unforeseen start-up. Isolation from connections to pressurization sources must be carried out.**

Before carrying out any work on the seal or system, the equipment must be shut down and the barrier region must be fully depressurized. Once this has been done the barrier gas supply to the Plan 74 control panel can be isolated.

**Do not isolate the barrier gas supply before the pump is made safe.** Once the barrier gas supply is isolated carefully vent any residual pressure from the panel and interconnecting pipe work and drain of any liquids before carrying out any maintenance.

If the pump/panel is to be removed cover any open tubing fittings/connections to prevent contamination.

**NOTE** It is recommended that a pressure test is carried out on the system after any repair and before operation on the equipment.



# API PLAN 74

## SEAL SYSTEMS

### Installation, Operation & Maintenance Instructions

## 7. Maintenance

Check the following as part of regular site walk-around checks for trouble-free operation:

- Check the condition of the coalescing filter element for contamination (see Section 7.2).
- Barrier pressure. Compare with the operating pressure on the nameplate.
- Barrier flow. Compare with the normal flow rate observed.
- Condition of alarm signals (see Section 7.3).

### 7.2 Filter

It is recommended that the element is checked after the first month of operation and if no contamination is detected thereafter at 6-month intervals.

Irrespective of visual condition it is recommended that the filter element is replaced annually.



**The filter bowl is pressurized and no attempt should be made to remove it until the barrier gas supply has been isolated and all residual pressure in the system safely vented. Note that the machine must also be stopped and depressurized before removing the barrier gas pressure.**

### 7.3 SIGNALS AND ALARMS

A sudden or noticeably steady increase in the gas consumption should be considered abnormal and may indicate a deteriorating seal. The instrumentation on the system has the specific purpose of signalling eventual malfunction of the mechanical seals. Possible alarm signals indicating a malfunction are as shown in Table 2.

### 7.3 SIGNALS AND ALARMS

A sudden or noticeably steady increase in the gas consumption should be considered abnormal and may indicate a deteriorating seal. The instrumentation on the system has the specific purpose of signalling eventual malfunction of the mechanical seals. Possible alarm signals indicating a malfunction are as shown in Table 2.

TABLE 2. Possible Alarm Signals Indicating a Malfunction

Effect	Instrument	Action	Cause
Falling Pressure	Pressure Gauge (PG) or Pressure Indicating Transmitter (PIT)	A	D to G
Low Pressure/Shutdown Required	Pressure Indicating Transmitter (PIT) or Pressure Switch (PS)	B	D to G
Falling Flow	Flow Indicating Transmitter (FIT) or Flow Indicator (FI)	C	F or G
Rising Flow	Flow Indicating Transmitter (FIT) or Flow Indicator (FI)	A	D or E
Pulsations in the Flow	Flow Indicating Transmitter (FIT) or Flow Indicator (FI)	—	H
High Flow Alert	Flow Indicating Transmitter (FIT) or Flow Switch (FS)	B	D, E or H

#### Actions

A	Investigate cause and monitor to ensure values do not breach safe limits
B	Shut down machine to prevent damage or loss of containment
C	Check coalescing filter and gas supply

#### Causes

D	Excessive leakage across the inboard seal or outboard seal
E	Pipe work/joint failure
F	Drop in the barrier gas supply pressure/flow
G	Blockage of the coalescing filter
H	Actuation of the check valve – see Section 6.2

The signal from the pressure transmitter can be used either:

- LOCALLY (with a Klaxon and/or beacon)
- REMOTELY (in the control room)

Consult the specific instrument manufacturers manual should there be a malfunction.

If necessary for safety, the process the alarm signals could be used as a trip function.



# API PLAN 74

## SEAL SYSTEMS

Installation, Operation & Maintenance Instructions

### 7.4 INSTRUMENT MAINTENANCE

All instruments require regular calibration, following local processes and regulations. See the supplier's instruction manual for and additional instructions for maintenance of electrical instruments.

### 7.5 SPARE PARTS

Spare parts must conform to the established technical specifications of the manufacturer. This is guaranteed with John Crane spare parts.

You are advised to stock the most important wear parts on site.

The following data is necessary for spare part orders:

- John Crane code/part number
- John Crane order/ref no.
- Part description
- Quantity

### 7.6 ANNUAL MAINTENANCE CHECKS

Disconnection shall be made by plant person in charge of authorization.

Before any maintenance operation the system, the machine must be stopped and depressurized, then the barrier gas pressure must be fully discharged, and the equipment allowed to cool to ambient temperature. A suitable container should be available to contain any liquid drained from the barrier system.

All parts requiring maintenance must be thoroughly decontaminated prior to any work commencing.

All joints should be checked for tightness and signs of barrier gas leakage. If present, all flange joints should be checked for tightness and, if necessary, gaskets changed using replacements available from John Crane.

### 8. Accompanying documents

Installation Drawing (job specific) or Typical Drawing and Operational Data Sheet.

A name and data plate is fitted to each Plan 74 control panel. It contains references and part numbers which must be quoted in any communication.

**For replacement parts please contact your local John Crane office, quoting the system code number.**

### 9. Cold environments

For environments with low ambient temperatures, winterization features may be added to the Plan 74. These may include:

- The Plan 74 control panel may be supplied mounted in a heated enclosure. The heating element requires electrical connection as part of the installation and assembly procedure (see Section 6.2).
- Heat tracing and/or insulation may be required to maintain the temperature of the barrier gas in the Plan 74. This heat tracing and/or insulation may be supplied with the Plan 74 control panel, or may be applied on site around all pipework and components during installation and assembly, leaving room to read instruments and operative valves.
- Care must be taken during commissioning and operation, that the Plan 74 is brought up to operating temperature before the machine is started, and the correct temperature is maintained throughout operation.



**North America**  
United States of America  
Tel: 1-847-967-2400

**Europe**  
United Kingdom  
Tel: 44-1753-224000

**Latin America**  
Brazil  
Tel: 55-11-3371-2500

**Middle East & Africa**  
United Arab Emirates  
Tel: 971-481-27800

**Asia Pacific**  
Singapore  
Tel: 65-6518-1800

If the products featured will be used in a potentially dangerous and/or hazardous process, your John Crane representative should be consulted prior to their selection and use. In the interest of continuous development, John Crane Companies reserve the right to alter designs and specifications without prior notice. It is dangerous to smoke while handling products made from PTFE. Old and new PTFE products must not be incinerated. ISO 9001 and ISO14001 Certified, details available on request.