

1. Foreword

This manual relates to matters affecting the operation of the T93FR separation seal within compressor machinery. It covers areas directly associated with the installation, removal, operation and maintenance of the separation seal. For other related subjects, such as the correct operation of associated systems or guidance when conducting hazard analysis (as may be required under the European ATEX Directives), consult with the compressor equipment supplier and their documentation.

The T93FR separation seals are robust in operation. However, any incorrect handling or assembly fitting can easily lead to seal damage. Therefore, John Crane's T93FR separation seals may only be installed, commissioned and maintained by a fully trained and authorized plant machinery specialist. This person must pay close attention to these instructions, the John Crane seal installation drawing, compressor equipment supplier's manuals and documentation and all relevant regulations. Failure to do this relieves the manufacturer John Crane from any liability or warranties. It is strongly recommended that the seals are fitted by John Crane trained and approved technicians.

If there are any seal problems that need an urgent response, please contact your local John Crane sales representative.

2. Safety

The safety notes refer to the arrangement supplied. They can never be exclusive, and must be used in conjunction with the relevant safety regulations for the machine, auxiliary equipment, plant and sealed fluid.

2.1 Warning symbols

The following symbols are used in this instruction manual to highlight information of particular importance



Danger

Mandatory instructions designed to prevent personal injury or extensive damage.

ATTENTION Special instructions or information to avoid damage to the system or its surroundings.

NOTE Information for easy installation and efficient operation.

Please comply with any additional warning signs on the system.

2.2 Safety instructions



Prior to any installation, removal, operation and maintenance of the T93FR separation seal, all personnel involved in these activities must have read and understood this document before the commencement of any work. If there is not adequate understanding, contact John Crane for further advice.

All personnel involved in the installation, operation and maintenance of the separation seal must have adequate training and understanding with regards to:

- The separation seals being used.
- The equipment being worked on, including any relevant auxiliary equipment and systems.

- All tooling and equipment associated with fitting and removing seals.

- The environment in which work is being carried out.

- Health, safety and environmental issues associated with the above points including all relevant local site, national and international health, safety and environmental procedures and regulations.

Any working practice that compromises safety must be avoided.

All personnel involved in the installation, removal, operation and maintenance of the separation seals must be authorized by the responsible party to work on the equipment that the seals are fitted to.

At all times, adequate personal protection equipment should be worn/used. This equipment needs to be suitable for the environment and surroundings that a person is working within.

At all stages in work relating to the separation seal, reference must be made to the John Crane installation drawing, this document and the compressor equipment supplier's manuals and documentation and all relevant regulations.

Separation seal cartridge disassembly is not required for normal operation and maintenance and must never be undertaken other than by a John Crane trained technician approved for the seal type being worked on. Where seals require inspection and refurbishment, please contact John Crane.

Modifications and/or alterations of the separation seal in any way are not permitted without the authority of John Crane. Failure to obtain this authority relieves the manufacturer John Crane from any liabilities or warranties.

In the event of an operating problem, the machinery must be immediately switched off and made safe. Problems must be solved promptly.

A small controlled gas flow (commonly called the seal leakage) will occur within the separation seal during normal seal operation. In cases of a worn or defective seals, the leakage volumes will increase. This leakage may be hazardous, toxic and or explosive.

Attention is also drawn to the fact that, on its own, separation seal leakage may not be dangerous. However, if it was to combine with other gases, liquids and/or substances with increased or decreased pressure and temperature or be subjected to heat and/or an ignition source, then the mixture may become hazardous, toxic and/or explosive.



All leakage will need to be collected and directed to a safe location by the equipment and systems that the separation seals are fitted/connected to. This needs to occur under all circumstances including when the separation seals ARE and ARE NOT working normally. It is the responsibility of the compressor/machine manufacturers and equipment operators to ensure that the systems and procedures are in place to accommodate this and that these systems provide adequate health and safety to all people, as well as protection for the environment.

In the rare case of catastrophic seal failures, a bulk escape of process gas and/or buffer gas within the compressor casing can occur past the separation seal. This leakage may be hazardous, toxic and/or explosive. It is the responsibility of the compressor/machine manufacturers and equipment operators to ensure that systems and procedures are in place to deal with this occurrence and that these systems provide adequate health and safety to all people, as well as protection for the environment.

Hot surfaces have to be protected against accidental contact.

Separation seals can become exposed to extreme conditions, particularly during process upset and seal failure. Suitable personal protection equipment must be worn during handling, removal and disassembly of previously used seals. This includes gloves, coveralls and footwear, as well as protective headgear appropriate to the location.

In addition, hazardous chemicals and dust can be present within the separation seals. A suitable FFP3 respirator is therefore recommended. (Apart from potentially unknown chemicals in the process fluids, if gross over-heating has occurred, hydrofluoric acid and other noxious compounds may be formed). Follow the local relevant guidelines for the safe and environmentally friendly disposal of assembly lubricants, supplied fluids and scrapped components.

When returning separation seals to John Crane, customers MUST confirm in writing that the specific seals being returned are safe to handle and provide any additional safety-critical information on request. This is further discussed in Appendix I of this document.

3. Seal Installation and Removal

NOTE Where the T93FR seal is supplied as an individual cartridge unit, follow these guidelines for installation and removal.

Where the T93FR seal is supplied as part of a dry gas seal cartridge, follow the dry gas IOM guidelines for installation and removal.



Any lifting equipment used for the installation and extraction of the separation seals must be adequate for the situation and comply to all health and safety requirements.

Any tooling used for the installation and extraction of the separation seals must be suitable for the duty it is being used for, in good condition and comply to all health and safety requirements.

3.1 Seal preparation

NOTE Seal installation and extraction tools are not supplied by John Crane. Consult the compressor equipment supplier's manuals and documentation for any special tool requirement or recommendations. An assessment of required fitting tooling should be made prior to carrying out any installation or removal of the separation seals and this tooling should be made available.

ATTENTION John Crane supplies separation seals in purpose-designed transportation cases and wrapped within cellophane or sealed bags. On initial unpacking of the seal from the case:

- Check packaging for visible signs of damage.
- Check consignment is complete with all items being present when compared to the list of items provided within the case.
- Open all packaging carefully. If sharp instruments such as knives or scissors are used, take care not to damage the O-ring sealing elements.

If there are any issues, contact John Crane.

Prior to installation, the entire outer surface of the separation seal cartridge including the seal bore should be clean and dry.



Do not fit the separation seal if the outside of the seal cartridge is significantly dirty, stained with hydrocarbon tar deposits or wetted with fluids as this may indicate the seal has been internally contaminated. In such an event contact John Crane.

Never clean the separation seal with cleaning fluids or solvents that could enter the cartridge and attack vulnerable components such as the O-rings or cause corrosion.

ATTENTION In the case of very minor dirt or fluid present on the outside of the separation seal cartridge that can be easily cleaned away and there is no risk of internal seal contamination, then it is possible to continue with seal installation. If in any doubt, contact John Crane.

All O-rings fitted to the outside diameter and in the bore of the cartridge should be carefully examined for damage such as cuts or crushing. If damaged, they should be replaced with a correct part from the spares/installation kit, in accordance with the installation drawing.

On certain separation seal designs, tolerance rings are located within the seal sleeve bore of the seal (Figure 1). The function of these tolerance rings is to centralize the seal rotor on the compressor shaft or other components. If during service the tolerance rings have become damaged and crushed then they can be replaced as per the instructions of Appendix II.

FIGURE 1. Sleeve fitted with tolerance strip

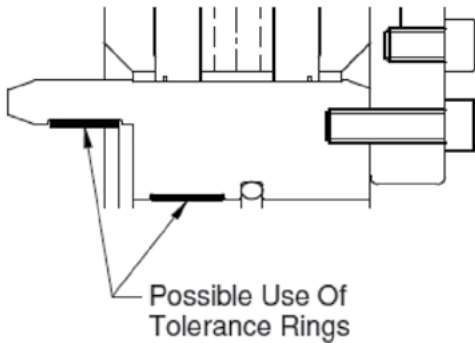

ATTENTION Carefully check all external screws on the cartridge for any signs of looseness that may have occurred. If any have become loose, re-tighten using an appropriate Allen key. If in any doubt, contact John Crane before installing the separation seal.

3.2 Compressor preparation



The compressor cavity into which the separation seal is fitted must be in accordance with the seal Installation drawing.

Prior to any work being carried out on the compressor, it must be in a safe condition. All pressures within the compressor casing need to be atmospheric pressure with no differential pressures present (including partial vacuum conditions). No hazardous or toxic gases or liquids must be present and any required decontamination procedures must be carried out. For further information, consult the compressor equipment supplier's manuals and documentation.

The compressor casing and shaft must be adequately earthed and electrical earth continuity must be maintained. See compressor equipment suppliers manual and documentation for details.

The following text assumes that the compressor has been made safe and that the required installation and extraction tools are available.

To provide lubrication between the compressor shaft and the separation seal rotor during installation, John Crane recommends the use of either:

- Dow Corning MolyKote® G-N Paste or MolyKote® G-N Plus Paste
- Jet-Lube White Knight™ anti-seize compound

The above individual substances should not be mixed and must be applied sparingly, and only at the seal bore/compressor shaft interface.

Installation, Operation & Maintenance Instructions

For any O-ring situated on the outside diameter only of the seal cartridge (outside diameter of the retainers of the seal stator), sparingly lubricate with a thin layer of silicone grease.

ATTENTION Under no circumstances must silicone grease be used for shaft/seal sleeve assembly lubrication otherwise shaft sleeve galling can occur.

Any excessive silicone grease and anti-seize compound must be removed, and care taken to prevent ingress of these lubricants into the separation seal during cartridge installation.

The suitability of alternative lubricants should be confirmed with John Crane.

1. Clean the entire area within the compressor into which the separation seal fits. Ensure that it is free from defects and any rough or sharp edges and burrs that could damage the seal on installation.
2. Ensure that the compressor shaft is positioned correctly to the compressor casing to allow fitting of the separation seal. Both the axial and radial alignment needs to be considered. Ensure that the shaft is angularly aligned with the casing such that any pin positions, keys, bolts or other features in the shaft and casing are aligned with the corresponding features within the separation seal with the installation plates fitted (see seal installation drawing and Figure 2). Consult the compressor equipment supplier's manual and documentation for appropriate method for shaft and casing alignment.

FIGURE 2. Separation seal with installation plates fitted

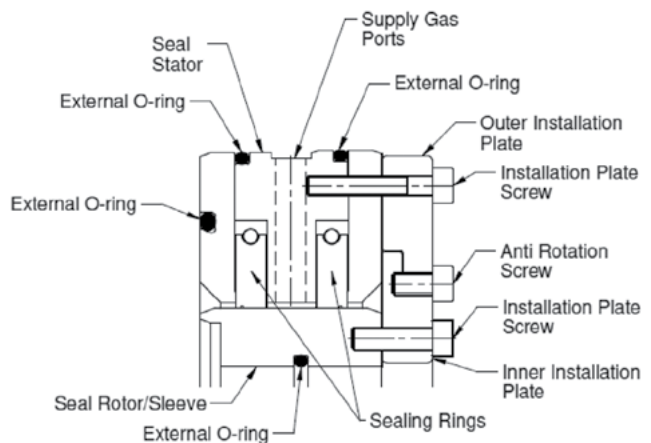

The compressor shaft should be locked to prevent it from moving while fitting the separation seal into position. For further information, consult the compressor equipment supplier's manuals and documentation.

3. If the T93FR separation seals have not been previously fitted to the compressor or if there is a new rotor, check that the seal chamber is in accordance with the installation drawings.
4. Apply a thin film of anti-seize compound to the compressor shaft.
5. Axial positioning shims or spacers may be provided. If supplied, these need to be adjusted by appropriate machining to achieve the correct rotor to stator working position. Once correctly adjusted, fit shims or spacers into the compressor or to seal cartridge as shown on the installation drawing or compressor equipment suppliers manuals and documentation.

3.3 Fitting the separation seals



Ensure that the separation seal cartridge is the correct one for the compressor shaft end that it is being fitted to. Consult equipment supplier's manuals and documentation to ascertain correct part numbers and compare these against the seal cartridge part numbers and the seal installation drawings.

1. Loosen all the screws of both the inner and outer installation plate fitted to the separation seal by one turn each only (see Figure 2). Do not loosen screws excessively.
2. Carefully position the separation seal onto the shaft. Where required, use appropriate lifting equipment to achieve this task.
3. Align any key ways, pins, slots, holes or other features within the separation seal with corresponding features sited within the compressor casing and shaft or other already fitted components. If there is minor angular misalignment between the compressor casing, compressor shaft and seal, remove any anti-rotation screw within the installation plates (Figure 2) and rotate the seal rotor until alignment is achieved. If misalignment is excessive see Compressor Preparation, number 2.
4. Using the fitting tools provided by the compressor manufacturer (or suitable studding and jacking bar), carefully and evenly jack the separation seal assembly into position by applying jacking force to the seal stator.



When fitting the separation seal, it is imperative that it is kept square to the shaft axis in order to prevent it binding onto the shaft.

5. When the separation seal is fully engaged home, remove all fitting tools.
6. Remove the seal installation plates and their screws as per the installation drawing.
7. Secure the seal stator into the compressor casing and the seal rotor to the shaft using the appropriate components as shown on the installation drawing or if not shown, then as per the compressor equipment supplier's manual and documentation.



Any John Crane supplied screws used to retain separation seal components must be tightened adequately. Where these screws are secured into non John Crane supplied parts, then consult with the compressor equipment suppliers manuals and documentation for any bolt torque requirements.

It is essential that the separation seal rotor is effectively locked onto the compressor shaft and the seal retainer effectively locked within the compressor chamber and that any locking devices are fully secured and tightened. Please consult the compressor equipment suppliers manuals and documentation.

Prior to any attempt to rotate the shaft, the separation seal installation plates and associated screws must be removed.

Complete compressor assembly as per the compressor equipment supplier's manuals and documentation.

If compressor shaft has been locked, ensure this has been removed prior to any compressor operation. Consult compressor equipment supplier's manual and documentation for further information.

3.4 Removal of the separation seal



Before removal of the separation seal, the compressor needs to be in a safe state. All pressures within the compressor casing need to be atmospheric pressure with no differential pressures present (including partial vacuum conditions). No hazardous or toxic gases or liquids must be present and any required decontamination procedures must be carried out. For further information, consult the compressor equipment supplier's manuals and documentation.

In accordance with the compressor equipment supplier's instructions, disassemble the compressor to the point where there is access to the separation seal.



The compressor shaft should be locked to prevent it from moving while removing the separation seal from the compressor. For further information, consult the compressor equipment supplier's manuals and documentation.

1. Carefully study the installation drawing. All devices that secure the separation seal stator and rotor to the compressor casing or shaft must be removed.
2. Fit the separation seal installation plates as identified on the installation drawing. It is not necessary to fit the anti-rotation screw (see Figure 2).
3. Fit the removal tools as provided by the compressor manufacturer (or suitable studding and jacking bar) to facilitate separation seal removal.
4. Fit any required lifting equipment.
5. Using these tools, extract the separation seal cartridge from the compressor housing by applying a jacking force to the seal stator.

- Remove the seal cartridge from the shaft. Use any required lifting equipment.



It is imperative that while extracting the separation seal cartridge, that the cartridge is kept square to the shaft axis in order to prevent it binding onto the shaft. If the separation seal is removed without the appropriate installation plates, severe damage may occur to the seal cartridge or the compressor shaft and cavity.

4. Commissioning Procedure



Once the separation seals have been installed into the compressor and prior to commissioning of the separation seals, all commissioning procedures as required by the compressor equipment supplier must be carried out and the compressor must be in a safe condition before any pressure is applied to the compressor or the compressor shaft is rotated or the compressor is operated. For further information, consult the compressor equipment supplier's manuals and documentation. The following text assumes that the compressor is in a safe condition in accordance with the above and that any required procedures have been carried out.

Prior to any bearing lubrication oil operation/ circulation, the separation seal needs to be commissioned and operating with the seal gas supply turned on. Separation seal gas needs to remain operational and the gas supply needs to remain on for the full time that bearing lubrication oil is in operation and circulating. The separation gas seal supply gas can only be turned off after the lubrication oil circulation is turned off. Failure to do this will result in contamination of the separation seal with lubrication oil.

Prior to the process gas being applied to any dry gas seal or process side of the separation seal, the separation seal needs to be commissioned and operating with the seal gas supply turned on.

Separation seal gas needs to remain operational and the gas supply needs to remain on for the full time that process gas is being applied. The separation gas seal supply gas can only be turned off after the process gas is no longer being applied and not before. Failure to do this will result in the possibility of process gas flowing through and past the separation seal.

4.1 Static test

This task should be undertaken following separation seal cartridge installation and prior to starting the compressor.

Installation, Operation & Maintenance Instructions

- Follow carefully the instructions in any relevant Dry Gas Seal IOM. The following points are additional and relate specifically to the separation seal.
- If not already done so as part of the dry gas seal commissioning then with the equipment drive coupling disconnected, it is recommended where possible to rotate the compressor shaft to ensure freedom of movement.
- Commission the separation seal system and ensure that it is functioning correctly.
- Pressurise the separation seals to the required operation pressure for the application.
- If excess supply gas consumption is observed or excessive leakage close to or greater than alarm settings is observed, then the compressor needs to be made safe and the cause of the high leakage rectified.

4.2 Dynamic operation

- Commence normal start up procedure as defined by the compressor equipment supplier's manual and documentation. Periodically record the separation seal supply gas consumption or leakage rate during the first four hours of operation or until full compressor operating conditions are reached dependent on which is longer.
- If excessive supply gas consumption or leakage is observed (i.e. close to or greater than alarm settings) then appropriate action should be taken to investigate the cause of the problem, including where necessary the shut down of the compressor.

5. Compressor Operation and Maintenance with T93FR

The separation seals are designed to cover the widest range of operating parameters and require virtually no maintenance. It is recommended that the seals should be continuously monitored (especially supply gas consumption or leakage) and data recorded using the compressor logging system. A trend of changing gas consumption, leakage, temperature, vibration or other parameters being monitored at or around the separation seal may give forewarning of a seal problem.

The following notes are intended for guidance.



OPERATING AND ENVIRONMENTAL CONDITIONS

The separation seal must not be subjected to operating conditions, environmental conditions, substances and fluids outside those defined by the contract of separation seal supply, the installation drawing and this document.

The separation seal supply gas must always be applied to the seal at the correct operating conditions before the bearing lubrication oil starts to circulate and only be turned off after the bearing lubrication system is turned off. Failure to do this will result in contamination of the separation seal with lubrication oil.



The separation seal supply gas must always be applied to the seal at the correct operating conditions before process gas is applied to any dry gas seal or process side of the separation seal. Separation seal supply gas can only be turned off after process gas is no longer applied.

Failure to do this will result in the possibility of process gas flowing through and past the separation seal.

Filters for the separation seal supply gas should be coalescing type and have a minimum efficiency of 99.9% for particles less than or equal to 10µm (beta ratio $\beta_1 \geq 1000$). Where required, gas conditioning systems should be employed to ensure clean gas supply and the removal of any liquids. Seal performance issues relating to contamination of any kind will not be covered by the seal warranty. John Crane can advise further on contamination issues and gas conditioning as required.

For optimum seal life, separation seals should be operated within the conditions as defined within the contract of seal supply. Compressor maintenance and satisfactory monitoring of operation parameters should be carried out to ensure this is the case and where performance trends are exceeding these conditions, corrective actions should be implemented prior to reaching alarm conditions. Examples of where this is good practice relates to parameters such as supply gas consumption, seal leakage, gas cleanliness and compressor vibration. If during operation an alarm value is encountered then this should be investigated and the cause rectified immediately. The separation seals should not operate continuously above alarm values. Separation seals must not be operated above any of the set trip values for compressor performance.

Compressor trip should be activated and the cause of the problem investigated if there is:

- Loss of separation seal supply gas.
- Excessive consumption of separation seal supply gas, such that an upstream pressure to downstream pressure across the separation seal sealing rings cannot be maintained.
- Excessive leakage and flow of gas to vent lines beyond trip.

The separation seal is not designed to accommodate reversive pressure unless this is stated within the conditions of the application. Where not stated as the conditions of the application, reverse pressure must be avoided.

While small quantities of bearing oil and/or hydrocarbon condensate on the surfaces of the separation seal are generally not detrimental, the general ingress of these substances into the seal must be avoided to permit good sealing performance and long life. Seals contaminated with bearing oil and/or hydrocarbon condensate should

Installation, Operation & Maintenance Instructions

not be operated. Contaminated seals should only be inspected and cleaned by a John Crane trained and approved technicians.

ATTENTION Check monthly for oil in the atmospheric vent lines between the separation seal and the dry gas seal. Drain any oil in these lines, and rectify the cause. If the level of oil is significant, the separation seal and any corresponding dry gas seal needs to be checked for contamination.

For periods of shutdown or if the compressor is stored for a prolonged time the separation seal should be isolated by blanking off all connecting ports.

Washing/cleaning of compressors

It is the practice of some compressor operators to "wash" or clean their machines internally while in service. John Crane can not recommend that such practices are applied in relation to the dry gas seals and the separation seal due to the danger of loosening contaminant within the compressor and then this becomes lodged in key areas of the seals. Where compressor washing is practiced, then the seals should at all times be buffered by a suitable clean gas supply fed inboard between the seal and the machine's labyrinth. Corrosive or reactive chemicals must not come into contact with the gas seal. Only gases, liquids and chemicals which have been specified in the contract of seal supply should be allowed to come into contact with the separation seals.

NOTE T93LR separation seals are bi-directional and reverse rotation is permissible.

6. Storage

John Crane separation seals should always be stored as follows:

- Seals and/or spare components should remain in their original packaging and purpose-built transportation case until required. After use, seals should always be returned to their case for further storage.
- Separation seals should always be stored as complete seal cartridge units with the installation plates properly fitted as shown on the installation drawings.
- The seals within their transportation cases should be stored indoors in a clean, dry environment at a temperature between 15° to 25°C/ 59° to 77°F.
- Care should be taken to position the transportation case such that the top of the case remains in the top position.
- Care should be taken to ensure that excessively heavy items are not placed on top of the transportation case, nor that cases are stacked in an unsafe manner.

The transportation case that the seals were originally dispatched in is suitable for subsequent shipments of fully assembled seals.



TYPE 93FR

SEPARATION SEAL

Installation, Operation & Maintenance Instructions

ATTENTION If the separation seals are to be stored inside the compressor for long periods, it is necessary to ensure that they do not become contaminated in any way and adequate precautions need to be taken to prevent this. If the compressor is shipped with the seals in situ, the shaft should be restrained to prevent movement and potential seal damage. All compressor connections should be sealed off, after ensuring that the atmosphere within the machine is dry. Preserving oil should not be allowed to contact the seal.

7. Service life

Separation seal cartridges need routine refurbishment at regular intervals. It is recommended that seals are returned to John Crane for refurbishment during regular scheduled shut downs.

The vast majority of T93LR separation seals are fitted with O-rings. In ideal conditions, seals equipped with O-rings have an expected storage and installed service time of up to 10 years combined. John Crane recommends sending spare seals back for inspection (health check) after storage, prior to installation.

However, the length of the successful installed service period will vary depending on the seal environment. For applications with intermittent and wet or dirty processes, the service life may be reduced. Seal condition should be assessed in operation by monitoring trends with separations seal gas consumption and/or leakage levels.

8. Transportation

ATTENTION It is essential that the separation seals are suitably packaged and always transported in the purpose-built transportation case supplied by John Crane.

The seals should be assembled as a cartridge unit with the installation plates fitted (preventing movement between the seal rotor and stator).

Any "loose" items placed inside the transportation case must be securely wrapped to prevent transit damage. For other shipping procedures see Appendix I.

For shipments over 16kg: To ensure safe handling, all items exceeding this weight threshold must be secured on pallets in addition to using the purpose-built transportation case.

For other shipping procedures see Appendix I.

APPENDIX I. Returning seals to John Crane

All separation seals should be returned to John Crane for any refurbishment. Prior to refurbishment, customers must confirm in writing that the specific seals being returned are safe to handle and provide any additional safety-critical information on request. John Crane can provide a suitable form for this purpose.

The following information must be made available on the shipping documentation.

1. Installation drawing numbers
2. Cartridge numbers
3. Value (for insurance only)
4. Commodity code 84842000000

For refurbishment, contact your local John Crane sales representative for shipping details of your nearest John Crane Turbomachinery Service Center.

APPENDIX II. Replacing tolerance rings

On certain separation seal designs, tolerance rings can be located within the sleeve bore (see Figure 1 and II.a). The function of these tolerance rings is to centralize the seal sleeve on the compressor shaft or on other rotor components. The tolerance ring fits into a groove machined into the bore of the sleeve and is glued in place. If the tolerance rings have become damaged and crushed during service they can be replaced as per the instructions below, though this may adversely affect the seal balance.

Exercise extreme care when handling tolerance ring as the edges can be sharp. Wear appropriate gloves throughout the fitting process.

The method of installing a tolerance ring is as follows:

1. Spare tolerance ring will be supplied within the separation seal spare kit. This will be secured in place with a two part quick acting adhesive such as Loctite Multi Bond (not supplied by John Crane).
2. For the tolerance ring already fitted to the seal, observe that the dimples of the tolerance ring are in the direction of the compressor shaft. When replacing tolerance ring, it should always be installed with the dimples in the correct direction and the gap in the same location as originally supplied. See Figure II.a.

FIGURE II.A

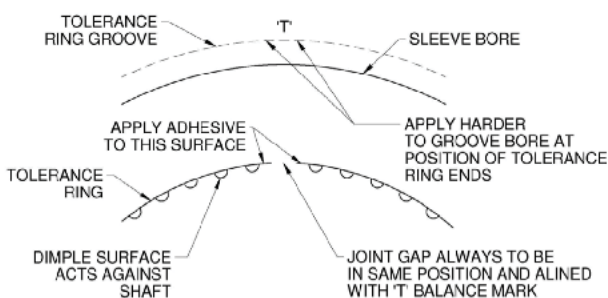

Installation, Operation & Maintenance Instructions

3. For the damaged tolerance ring to be removed, mark the location of the tolerance ring gap with an appropriate pen.
4. Remove the old tolerance ring and all traces of adhesive or weld joint debris from the groove in the sleeve bore.
5. Using a small pair of tin-snips, carefully cut a new tolerance ring between "waves" to slightly longer length than required.
6. With the dimples of the ring on the inside of curve (see point 2), curl the tolerance ring to the best possible fit of the groove.
7. Trim the tolerance ring length such that a 5mm/0.200" gap is established between the ends of the tolerance ring when fitted into the groove. Cut the chamfered profile as shown in Figure II.b. on both ends.

FIGURE II.B

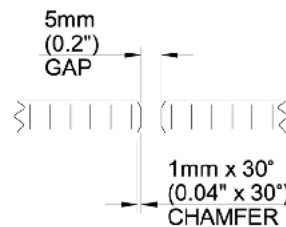

8. Clean the tolerance ring and the sleeve bore grooves with a suitable solvent.
9. The tolerance ring is held in place by a two part quick acting adhesive such as Loctite Multi Bond. Apply adhesive sparingly to three waves only at one end of the replacement tolerance ring.
10. Ensuring the tolerance ring gap is in the correct position, apply hardener to the sleeve groove over a similar length.
11. Locate the tolerance ring within its groove. Apply thumb pressure to the tolerance ring in the region of the adhesive until the adhesive has set.
12. Repeat steps 9, 10 and 11 for the other end of the replacement tolerance ring ensuring that the ring is pushed fully back around the circumference of the groove.
13. When the adhesive is fully set, remove any excess adhesive from the seal bore that interferes with seal fitting.

ATTENTION

It is essential the tolerance ring is fully located in the appropriate groove. If excessive glue is used, it can result to shaft damage.



TYPE 93FR

SEPARATION SEAL

Installation, Operation & Maintenance Instructions



North America United States of America Tel: 1-847-967-2400	Europe United Kingdom Tel: 44-1753-224000	Latin America Brazil Tel: 55-11-3371-2500	Middle East & Africa United Arab Emirates Tel: 971-481-27800	Asia Pacific Singapore Tel: 65-6518-1800
---	--	--	---	---

If the products featured will be used in a potentially dangerous and/or hazardous process, your John Crane representative should be consulted prior to their selection and use. In the interest of continuous development, John Crane Companies reserve the right to alter designs and specifications without prior notice. It is dangerous to smoke while handling products made from PTFE. Old and new PTFE products must not be incinerated. ISO 9001 and ISO14001 Certified, details available on request.