

- A – Mating ring
- B – Primary ring
- C – Retainer
- D – Springs
- E – O-rings
- F – Set screws

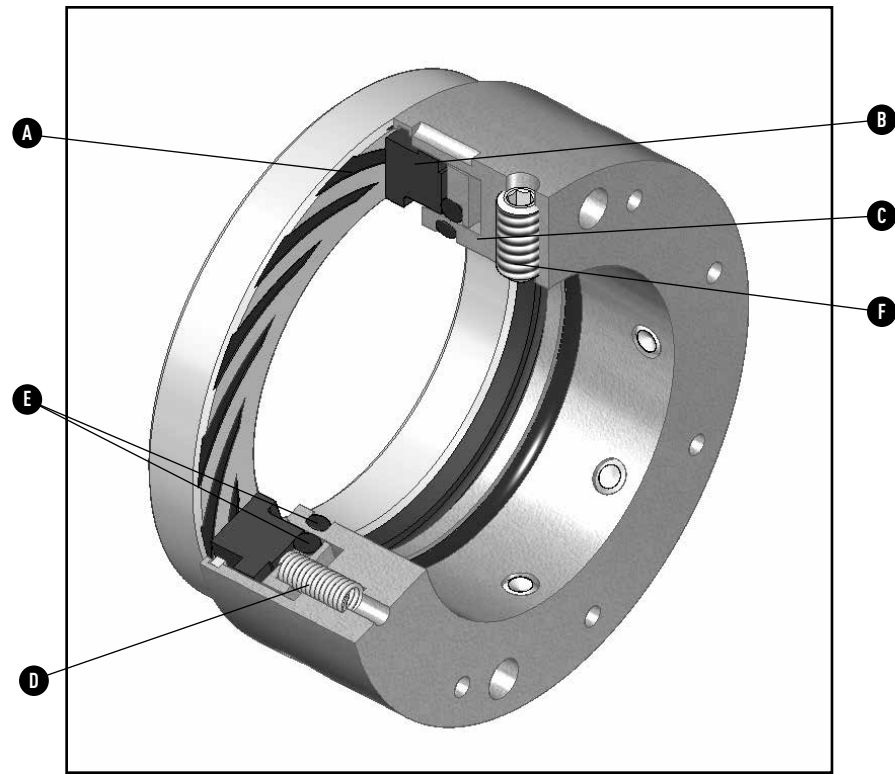

Bi-directional pattern optional



### Product Description

The type 28SCB is a compact dry running non-contacting gas seal designed for secondary containment.

Secondary containment seals perform in response to primary seal leakage or failure and represent a less complex alternative to a dual unpressurized (tandem) seals using a Plan 52 lubrication system.

Normal leakage from the primary seal is small and measured in ppm. The use of a containment seal gland and buffer gas injection moves vaporous leakage to a flare system. The 28SCB is typically applied with a Plan 72/76 secondary seal support system. When called upon to seal gross primary seal leakage, 28SCB closes down to run as a contacting wet seal directing leakage to a flare system or drain.

### Performance Capabilities\*

- Temperature: -20°F to 500°F/-29°C to 260°C\*\*
- Pressure: Up to 232 psig/16 barg (gas operation)  
Up to 1,160 psig/80 barg (liquid operation)\*
- Speed: 1,450 to 3,600 rpm\*

\*For pressure and speeds outside this range, please consult John Crane Engineering.

\*\*See Elastomer Temperature Limits

### Design Features

- Balanced design allows higher gas pressure operation
- Non-contacting seal — near zero wear or maintenance, no need for liquid face lubrication, low power usage, high vapor recovery system or flare pressure tolerance
- Unidirectional and bidirectional mating rings
- Compact short axial length
- Simplified dual containment using Plan 72/76
- Spiral groove pattern on mating ring pumps a small amount of inert buffer gas from the outside diameter towards the ungrooved portion of the mating ring. This compressed gas cushion separates the primary seal face and mating ring and creates a non-contacting seal
- Contains process liquid in the event of primary seal failure and handles up to 1,160 psig/80 barg in contacting mode
- Can operate in a vacuum as outside mounted single seal
- Can operate as a single seal in a blower, fan and turbine with safe, clean and dry gas

# TYPE 28SCB

## DRY-RUNNING, SECONDARY CONTAINMENT BALANCED GAS SEAL

Technical Specification

### Type 28SCB Typical Arrangement/Dimensional Data

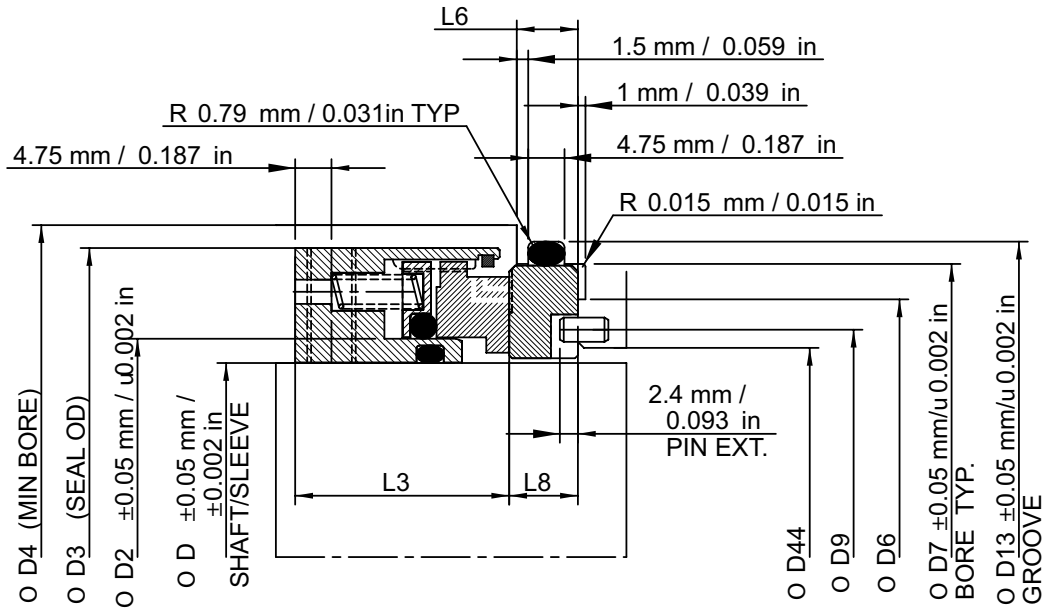

### Type 28SCB Dimensional Data (mm)

Seal Size (mm)	Size Code	D	D2	D3	D4	D6	D7	D9	D13	D44	L3	L6	L8
25.4	0254	25.40	31.75	55.50	61.49	42.06	51.33	34.14	57.18	29.36	28	8	9
28.5	0285	28.58	34.93	58.67	64.67	45.16	54.43	37.34	60.27	32.46	28	8	9
31.7	0317	31.75	38.10	61.85	67.84	48.36	57.63	40.49	63.47	35.66	28	8	9
34.9	0349	34.93	41.28	65.02	71.02	51.56	60.83	43.69	66.68	38.86	28	8	9
38.1	0381	38.10	44.45	68.20	74.19	54.76	64.03	46.84	69.88	42.06	28	8	9
41.2	0412	41.28	47.63	71.37	77.37	57.86	67.13	50.04	72.97	45.16	28	8	9
44.4	0444	44.45	50.80	74.55	80.54	61.06	70.33	53.19	76.17	48.36	28	8	9
47.6	0476	47.63	53.98	77.72	83.72	64.26	73.53	56.39	79.38	51.56	28	8	9
50.8	0508	50.80	57.15	80.90	86.89	67.46	76.73	59.54	82.58	54.76	28	8	9
53.9	0539	53.98	60.33	84.07	90.07	70.56	79.83	62.74	85.67	57.86	28	8	9
57.1	0571	57.15	63.50	87.25	93.24	73.76	83.03	65.89	88.87	61.06	28	8	9
60.3	0603	60.33	66.68	90.42	96.42	76.96	86.23	69.09	92.08	64.26	28	8	9
63.5	0635	63.50	69.85	93.60	99.59	80.16	89.43	72.24	95.28	67.46	28	8	9
66.6	0666	66.68	73.03	96.77	102.77	83.26	92.53	75.44	98.37	70.56	28	8	9
69.8	0698	69.85	76.20	99.95	105.94	86.46	95.73	78.59	101.57	73.76	28	8	9
73.0	0730	73.03	79.38	107.14	113.13	92.84	102.92	81.79	108.76	76.96	30	9	10
76.2	0762	76.20	82.55	110.31	116.31	96.04	106.12	84.94	111.96	80.16	30	9	10
79.3	0793	79.38	85.73	113.49	119.48	99.14	109.22	88.14	115.06	83.26	30	9	10
82.5	0825	82.55	88.90	116.66	122.66	102.34	112.42	91.29	118.26	86.46	30	9	10
85.7	0857	85.73	92.08	119.84	125.83	105.54	115.62	94.49	121.46	89.66	30	9	10
88.9	0889	88.90	95.25	123.01	129.01	108.74	118.82	97.64	124.66	92.86	30	9	10
92.0	0920	92.08	98.43	126.19	132.18	111.84	121.92	100.84	127.76	95.96	30	9	10
95.2	0952	95.25	101.60	129.36	135.36	115.04	125.12	103.99	130.96	99.16	30	9	10
98.4	0984	98.43	104.78	132.54	138.53	118.24	128.32	107.19	134.16	102.36	30	9	10
101.6	1016	101.60	107.95	135.71	141.71	121.44	131.52	110.34	137.36	105.56	30	9	10
104.7	1047	104.78	111.13	138.89	144.88	124.54	134.62	113.54	140.46	108.66	30	9	10
107.9	1079	107.95	114.30	142.06	148.06	127.74	137.82	116.69	143.66	111.86	30	9	10
111.1	1111	111.13	117.48	145.24	151.23	130.94	141.02	119.89	146.86	115.06	30	9	10
114.3	1143	114.30	120.65	148.41	154.41	134.14	144.22	123.04	150.06	118.26	30	9	10

### Type 28SCB Dimensional Data (inches)

Seal Size (inches)	Size Code	D	D2	D3	D4	D6	D7	D9	D13	D44	L3	L6	L8
1.000	0254	1.000	1.250	2.185	2.421	1.656	2.021	1.344	2.251	1.156	1.103	0.315	0.354
1.125	0285	1.125	1.375	2.310	2.546	1.778	2.143	1.470	2.373	1.278	1.103	0.315	0.354
1.250	0317	1.250	1.500	2.435	2.671	1.904	2.269	1.594	2.499	1.404	1.103	0.315	0.354
1.375	0349	1.375	1.625	2.560	2.796	2.030	2.395	1.720	2.625	1.530	1.103	0.315	0.354
1.500	0381	1.500	1.750	2.685	2.921	2.156	2.521	1.844	2.751	1.656	1.103	0.315	0.354
1.625	0412	1.625	1.875	2.810	3.046	2.278	2.643	1.970	2.873	1.778	1.103	0.315	0.354
1.750	0444	1.750	2.000	2.935	3.171	2.404	2.769	2.094	2.999	1.904	1.103	0.315	0.354
1.875	0476	1.875	2.125	3.060	3.296	2.530	2.895	2.220	3.125	2.030	1.103	0.315	0.354
2.000	0508	2.000	2.250	3.185	3.421	2.656	3.021	2.344	3.251	2.156	1.103	0.315	0.354
2.125	0539	2.125	2.375	3.310	3.546	2.778	3.143	2.470	3.373	2.278	1.103	0.315	0.354
2.250	0571	2.250	2.500	3.435	3.671	2.904	3.269	2.594	3.499	2.404	1.103	0.315	0.354
2.375	0603	2.375	2.625	3.560	3.796	3.030	3.395	2.720	3.625	2.530	1.103	0.315	0.354
2.500	0635	2.500	2.750	3.685	3.921	3.156	3.521	2.844	3.751	2.656	1.103	0.315	0.354
2.625	0666	2.625	2.875	3.810	4.046	3.278	3.643	2.970	3.873	2.778	1.103	0.315	0.354
2.750	0698	2.750	3.000	3.935	4.171	3.404	3.769	3.094	3.999	2.904	1.103	0.315	0.354
2.875	0730	2.875	3.125	4.218	4.454	3.655	4.052	3.220	4.282	3.030	1.181	0.356	0.394
3.000	0762	3.000	3.250	4.343	4.579	3.781	4.178	3.344	4.408	3.156	1.181	0.356	0.394
3.125	0793	3.125	3.375	4.468	4.704	3.903	4.300	3.470	4.530	3.278	1.181	0.356	0.394
3.250	0825	3.250	3.500	4.593	4.829	4.029	4.426	3.594	4.656	3.404	1.181	0.356	0.394
3.375	0857	3.375	3.625	4.718	4.954	4.155	4.552	3.720	4.782	3.530	1.181	0.356	0.394
3.500	0889	3.500	3.750	4.843	5.079	4.281	4.678	3.844	4.908	3.656	1.181	0.356	0.394
3.625	0920	3.625	3.875	4.968	5.204	4.403	4.800	3.970	5.030	3.778	1.181	0.356	0.394
3.750	0952	3.750	4.000	5.093	5.329	4.529	4.926	4.094	5.156	3.904	1.181	0.356	0.394
3.875	0984	3.875	4.125	5.218	5.454	4.655	5.052	4.220	5.282	4.030	1.181	0.356	0.394
4.000	1016	4.000	4.250	5.343	5.579	4.781	5.178	4.344	5.408	4.156	1.181	0.356	0.394
4.125	1047	4.125	4.375	5.468	5.704	4.903	5.300	4.470	5.530	4.278	1.181	0.356	0.394
4.250	1079	4.250	4.500	5.593	5.829	5.029	5.426	4.594	5.656	4.404	1.181	0.356	0.394
4.375	1111	4.375	4.625	5.718	5.954	5.155	5.552	4.720	5.782	4.530	1.181	0.356	0.394
4.500	1143	4.500	4.750	5.843	6.079	5.281	5.678	4.844	5.908	4.656	1.181	0.356	0.394

### Mating Ring Groove Pattern

'CCW' Mating Ring

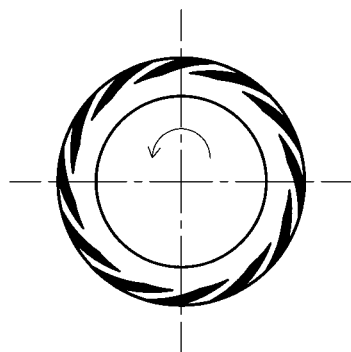

- Shaft rotation is counterclockwise
- Facing spiral groove pattern
- Mating ring is stationary

'CW' Mating Ring

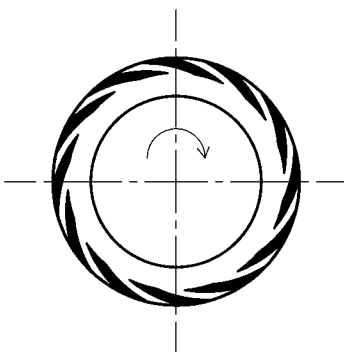

- Shaft rotation is clockwise
- Facing spiral groove pattern
- Mating ring is stationary

'BI' Mating Ring

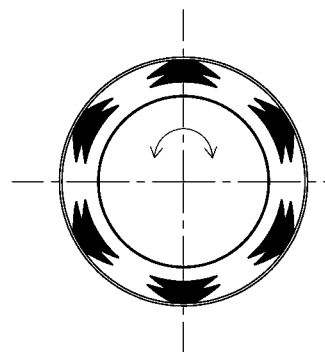

- Shaft rotation is bidirectional
- Facing spiral groove pattern
- Mating ring is stationary

### Materials of Construction

Seal Components	Materials	
Description	Standard	Options
Primary ring	Antimony impregnated carbon (9048)	—
Mating ring	Tungsten carbide (9205)	Silicone carbide (9221)
O-rings	Fluoroelastomer (9549)	Perfluoroelastomer (9579) Nitrile (9501) Ethylene propylene (9561)
Springs	Hastelloy C-276 (0690)	316 Stainless steel (0550)
Retainer	316 stainless steel (0550)	Alloy C-276 (0690) Alloy 20CB 3SS (0560)
Set screws Thrust ring Snap ring	316 stainless steel (0550)	Alloy C-276 (0690)

### Elastomer Temperature Limits

Material	Temperature
Fluoroelastomer (9549)	-20°F to 401°F/-29°C to 205°C
Perfluoroelastomer (9579)	0°F to 500°F/-18°C to 260°C
Nitrile (9501)	-40°F to 225°F/-40°C to 107°C
Ethylene propylene (9561)	-50°F to 300°F/-45°C to 149°C

### Criteria for Installation

Shaft Sleeve	Limits
Shaft diameter	+0.000"/+0.00 mm -0.002"/-0.05 mm
Shaft finish	63 µin Ra / 1.6 µm Ra
Shaft runout	0.002"/0.050 mm
Shaft end play	0.005"/0.13 mm
Squareness	0.003"/0.08 mm FIM
Concentricity	0.005"/0.13 mm FIM



**North America**  
United States of America  
Tel: 1-847-967-2400  
Fax: 1-847-967-3915

**Europe**  
United Kingdom  
Tel: 44-1753-224000  
Fax: 44-1753-224224

**Latin America**  
Brazil  
Tel: 55-11-3371-2500  
Fax: 55-11-3371-2599

**Middle East & Africa**  
United Arab Emirates  
Tel: 971-481-27800  
Fax: 971-488-62830

**Asia Pacific**  
Singapore  
Tel: 65-6518-1800  
Fax: 65-6518-1803

If the products featured will be used in a potentially dangerous and/or hazardous process, your John Crane representative should be consulted prior to their selection and use. In the interest of continuous development, John Crane Companies reserve the right to alter designs and specifications without prior notice. It is dangerous to smoke while handling products made from PTFE. Old and new PTFE products must not be incinerated. ISO 9001 and ISO 14001 Certified, details available on request.