



TYPE 8628VL

MULTIPHASE LUBRICATING ETHANE PIPELINE SEAL

Technical Specification

- A – Primary Ring
- B – Mating Ring
- C – Spring
- D – Retainer
- E – Labyrinth
- F – Sleeve

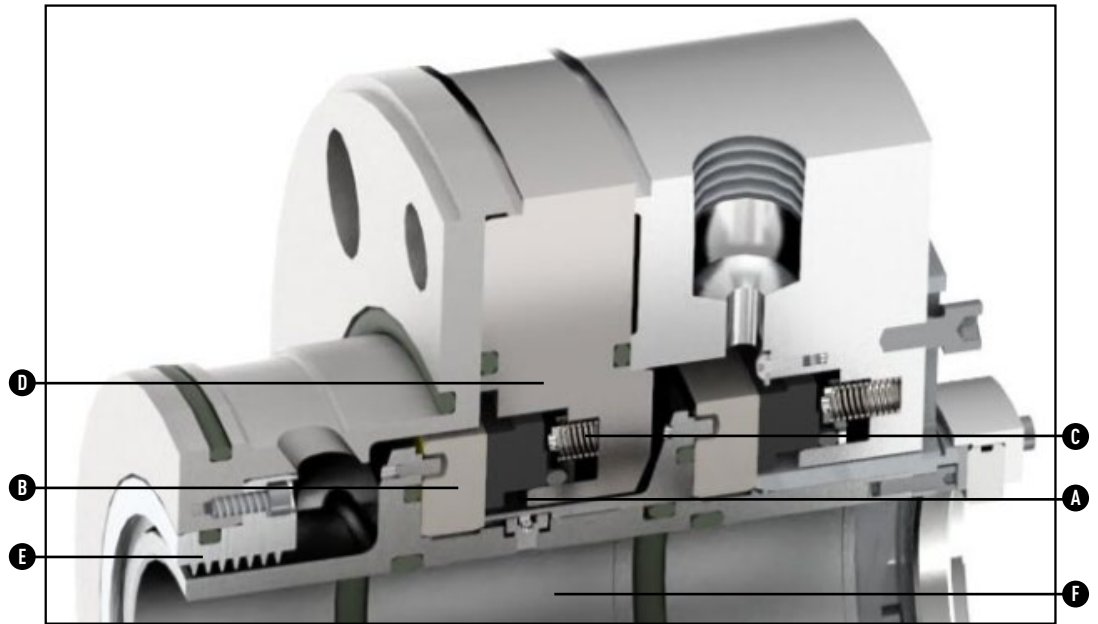

Product Description

John Crane's Type 8628VL is a standardised pusher mechanical seal using spiral groove face technology, designed specifically for difficult multi-phase ethane pipeline applications, with a focus on meeting the demanding requirements of ethane pipeline pumping station duties. Available as a dual arrangement, the seal can be configured to suit both the operator and pipeline needs.

- The main risk of seal failure in these applications is due to the numerous problems associated with start-up conditions, potentially resulting in high leakage preventing startup of the pump. The omni phase groove design of the Type 8628VL completely eliminates these common problems.
- By allowing operation without the potential for seal problems, the Type 8628VL provides longevity and reliability even in the most difficult pipeline applications.
- Seals can be repaired easily at any John Crane Service Center.

Performance Capabilities

- Temperatures:
-26°C to 121°C (-15°F to 250°F)
- Pressures:
103 barg (1500 psig) dynamic operating
124 barg (1800 psi) static operating
155 barg (2250 psig) static structural integrity
- Speed:
1450 to 3600 rpm
Up to 25.4 m/s (5000 fpm)

Design Features

- A film riding, non-contacting sealing solution that uses spiral groove technology to seal ethane at pipeline pressures without face contact.
- Unlike face contacting seals (typically tandem seals that use API plan 12 (filtered flush) and plan 76 that depend upon liquid ethane for lubrication or sophisticated lubrication systems that use special barrier fluids, the Type 8628VL from John Crane is non-contacting and uses process fluid and vapourisation to deliver reliable lubrication & extended MTBR for pipeline operators.
- Sealing purity ethane and ethylene in both static and dynamic conditions with a non-contacting multi-phase lubricating spiral groove design that operates reliably in super critical fluids, vapour, or liquid phases, creating hydrodynamic lift and a fully non-contacting seal face.
- Non-contacting operation results in no face wear, often 48 months of MTBR and superior reliability.



TYPE 8628VL

MULTIPHASE LUBRICATING ETHANE PIPELINE SEAL

Technical Specification

Type 8628VL Typical Arrangement

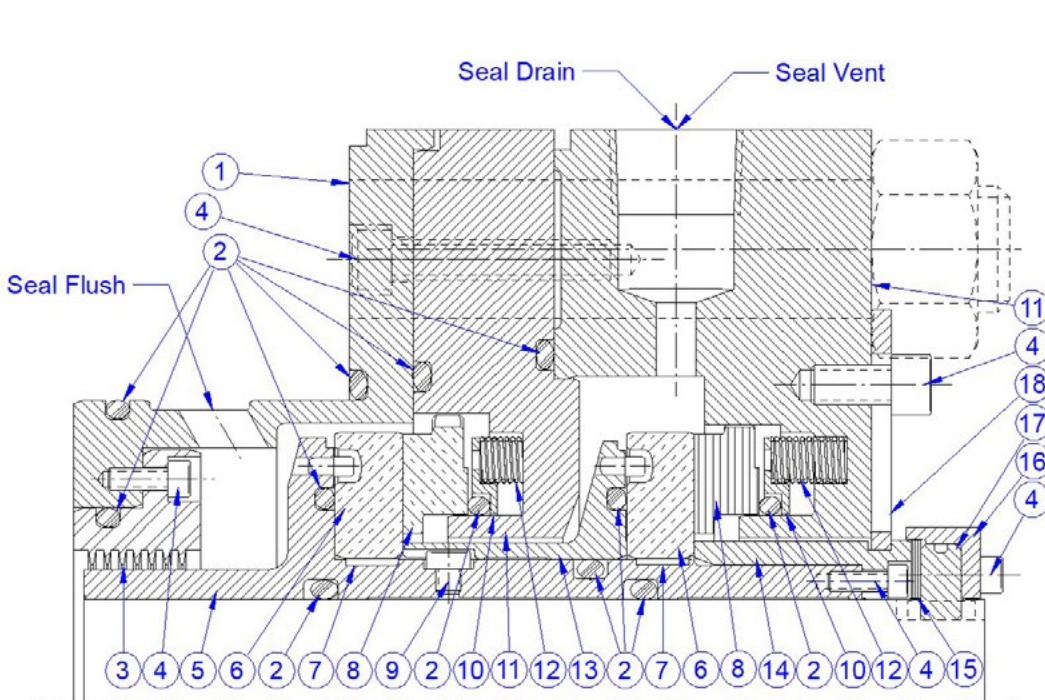

- 1 – Labyrinth Adapter
- 2– O-ring
- 3– Labyrinth
- 4– Cap Screw
- 5– Sleeve
- 6– Mating Ring
- 7– Tolerance Ring
- 8– Primary Ring
- 9– Drive Screw
- 10– Spring Disc
- 11– Retainer
- 12– Spring
- 13– Spacer Sleeve
- 14– Collar
- 15– Shim
- 16– Retaining Collar
- 17– Thrust Ring
- 18– Spacer

Type 8628VL General Installation Instruction

1. Be sure to read all instructions carefully before installing seal.
2. John Crane's Type 8628VL seals are precision products and are shipped as completely assembled cartridge seals for ease of installation.
3. Review the application specific installation (Layout) drawing and become familiar with the seal components, their location and function within the cartridge. The application specific seal may differ from that shown here.
4. Seals are uni-directional and can only be operated in the correct direction of shaft rotation (Clockwise or Counter-Clockwise). Be sure that you are installing the appropriate seal in the pump position which ensures the correct direction of shaft rotation.

Installation Criteria for Pump Shaft / Sleeve

Shaft/Sleeve	Limits
Surface Finish	1.6 μm / 63 Ra
Ovality/Out of Roundness (Shaft)	0.025 mm / 0.001"
End Play/Axial Float Allowance	\pm 0.13 mm / 0.005"



TYPE 8628VL

MULTIPHASE LUBRICATING ETHANE PIPELINE SEAL

Technical Specification

Dynamic Pressure Rating

Type 8628VL Dynamic Pressure Rating

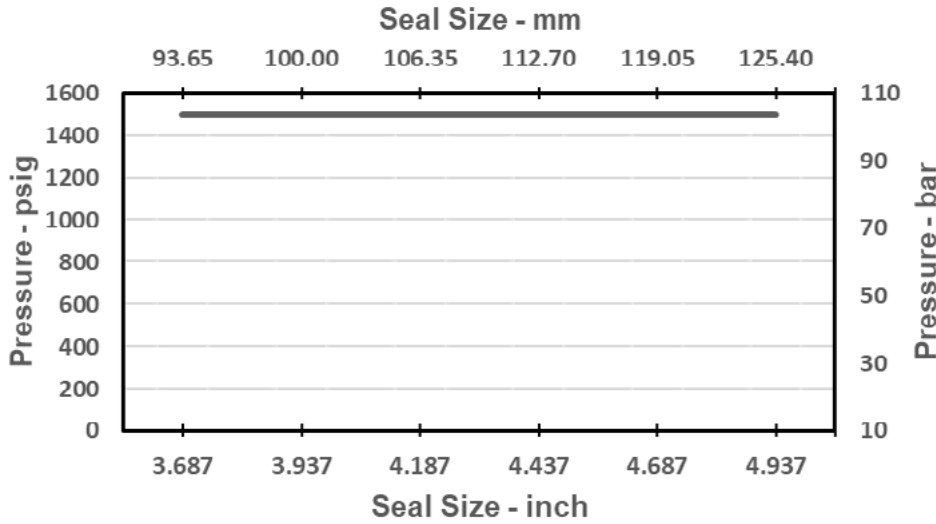

Materials of Construction

SEAL COMPONENTS	MATERIALS	
	Description	Options
Primary Ring	Silicon Carbide (Inboard) Carbon (Outboard)	
Mating Ring	Silicon Carbide	
O-ring	Flurocarbon	Buna
Seal Adaptive Hardware	410 Stainless Steel	NACE Compliant 410 S.S.



North America
United States of America
Tel: 1-847-967-2400

Europe
United Kingdom
Tel: 44-1753-224000

Latin America
Brazil
Tel: 55-11-3371-2500

Middle East & Africa
United Arab Emirates
Tel: 971-481-27800

Asia Pacific
Singapore
Tel: 65-6518-1800

If the products featured will be used in a potentially dangerous and/or hazardous process, your John Crane representative should be consulted prior to their selection and use. In the interest of continuous development, John Crane Companies reserve the right to alter designs and specifications without prior notice. It is dangerous to smoke while handling products made from PTFE. Old and new PTFE products must not be incinerated. ISO 9001 and ISO14001 Certified, details available on request.