

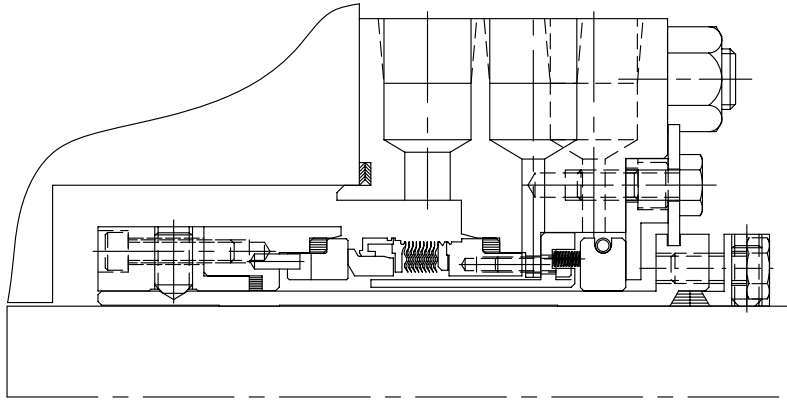

1604HTC/2609HTC/ 3609HTC/2609HTL/3609HTL

SEAL SYSTEMS

Installation, Operation & Maintenance Instructions



Foreword

These instructions are provided to familiarize the user with the seal and its designated use. The instructions must be read and applied whenever work is done on the seal, and must be kept available for future reference.

ATTENTION These instructions are for the installation and operation of a seal as used in rotating equipment and will help to avoid danger and increase reliability. The information required may change with other types of equipment or installation arrangements. These instructions must be read in conjunction with the instruction manuals for both the pump and any ancillary equipment.

If the seal is to be used for an application other than that originally intended or outside the recommended performance limits, John Crane must be contacted before its installation and use.

Any warranty may be affected by improper handling, installation, or use of this seal. Contact John Crane for information as to exclusive product warranty and limitations of liability.

If questions or problems arise, contact your local John Crane or the original equipment manufacturer, as appropriate.

ATTENTION John Crane mechanical seals are precision products and must be handled appropriately. Take particular care to avoid damage to lapped sealing faces and to flexible sealing rings. Do not excessively compress the seal before or during installation.

Safety instructions

1. The following designations are used in the installation instructions to highlight instructions of particular importance.

NOTE Refers to special information on how to install or operate the seal most efficiently.

ATTENTION Refers to special information or instructions directed towards the prevention of damage to the seal or its surroundings.



Refers to mandatory instructions designed to prevent personal injury or extensive damage to the seal or its surroundings.

2. Installation, removal and maintenance of the seal must be carried out only by qualified personnel who have read and understood these installation instructions.
3. The seal is designed exclusively for sealing rotating shafts. The manufacturer cannot be held liable for use of the seal for purposes other than this.
4. The seal must only be used in technically perfect condition, and must be operated within the recommended performance limits in accordance with its designated use set out in these installation instructions.
5. If the pumped fluid is hazardous or toxic, appropriate precautions must be taken to ensure that any seal leakage is adequately contained. Further information on sealing hazardous or toxic fluids should be obtained from John Crane prior to seal installation.
6. Fluorocarbon components should never be burned or incinerated as the fumes and residue can decompose. Protective gloves should be worn as hydrofluoric acid may be present.
7. PTFE components should never be burned or incinerated as the fumes are highly toxic.

Before starting the equipment

1. Check the pump at the coupling for proper alignment of the driver or motor.
2. Ensure that the gland plate nuts/bolts are securely tightened according to the pump manual instructions and all screws are securely fastened.
3. Complete the assembly of the pump and turn the shaft (by hand if possible) to ensure free rotation.
4. Consult all available equipment operating instructions to check for correctness of all piping and connections, particularly regarding seal recirculation/flush, heating or cooling requirement and services external to the seal.

ATTENTION This mechanical seal is designed to operate in a liquid so the heat energy it creates is adequately removed. The following check should be carried out not only after seal installation, but also after any period of equipment inactivity.



1604HTC/2609HTC/ 3609HTC/2609HTL/3609HTL

SEAL SYSTEMS

Installation, Operation & Maintenance Instructions

5. Check that the seal chamber fluid lines are open and free of any obstruction, and ensure that the seal chamber is properly vented and filled with liquid. Refer to the pump instruction manual.

ATTENTION Dry-running, often indicated by a squealing noise from the seal area, will cause overheating and scoring or other damage to the sealing surfaces, resulting in excessive leakage or a much shortened seal life.



Before startup, ensure that all personnel and assembly equipment have been moved to a safe distance so there is no contact with rotating parts on the pump, seal, coupling or motor.

WARNING Seal installation should be handled only by qualified personnel. If questions arise, contact the local John Crane representative. Improper use and/or installation of this product could result in injury to the person and/or harmful emissions to the environment, and may affect any warranty on the product. Please contact the company for information as to exclusive product warranty and limitations of liability.

Operating conditions

GENERAL INSTRUCTIONS

Study the engineering layout drawing to confirm the proper seal arrangement for the pump being used. The following instructions describe the standard configurations.

To assure satisfactory operation, handle seal with care. Take particular caution to see that the lapped sealing faces are not scratched or damaged.

TYPICAL TYPE 1604HTC SEAL ARRANGEMENT

- | | |
|----------------------------------|-------------------------|
| 1 – Mating ring adaptor assembly | 9 – Set screw |
| 2 – Mating ring | 10 – Locking washer |
| 3 – 604HTC head assembly | 11 – Hex head cap screw |
| 4 – Bushing | 12 – Gland bolts |
| 5 – Sleeve | 13 – Gland |
| 6 – Sleeve packing | 14 – Gland packing |
| 7 – Packing follower | 15 – Steam guide |
| 8 – Hex head cap screw | |

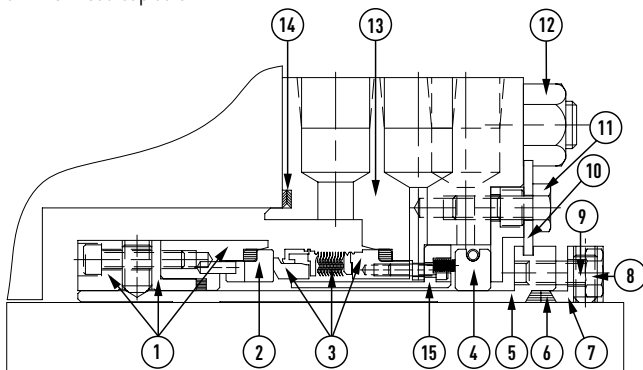

TYPICAL TYPE 2609HTC/3609HTC SEAL ARRANGEMENT

- | | |
|-----------------------------------|-------------------------------------|
| 1 – 609HTC rotary assembly | 9 – Set screw |
| 2 – Mating ring assembly | 10 – Spacer |
| 3 – 609 or 609HTC rotary assembly | 11 – Hex head cap screw |
| 4 – Mating ring assembly | 12 – Gland bolts |
| 5 – Sleeve | 13 – Gland |
| 6 – Sleeve packing | 14 – Gland packing |
| 7 – Packing follower | 15 – Dual scroll pumping device |
| 8 – Hex head cap screw | 16 – Flow guide (diverter optional) |

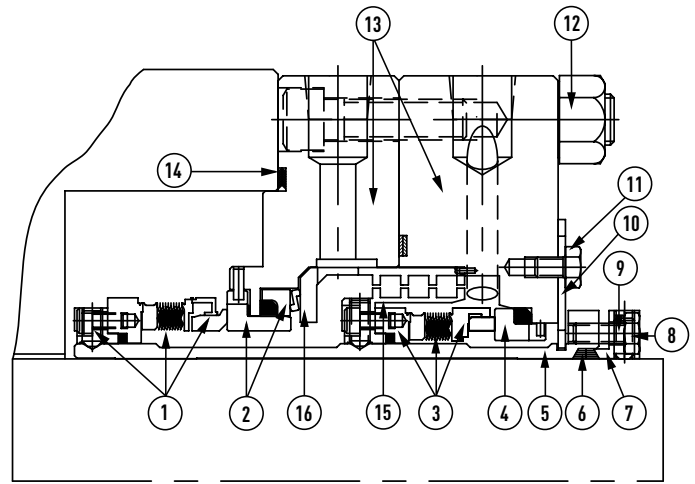

TYPICAL TYPE 2609HTL/3609HTL SEAL ARRANGEMENT

- | | |
|--------------------------|-------------------------------------|
| 1 – 609 Rotary assembly | 9 – Set screw |
| 2 – Mating ring assembly | 10 – Spacer |
| 3 – 609 rotary assembly | 11 – Hex head cap screw |
| 4 – Mating ring assembly | 12 – Gland bolts |
| 5 – Sleeve | 13 – Gland |
| 6 – Sleeve packing | 14 – Gland packing |
| 7 – Packing follower | 15 – Dual scroll pumping device |
| 8 – Hex head cap screw | 16 – Flow guide (diverter optional) |

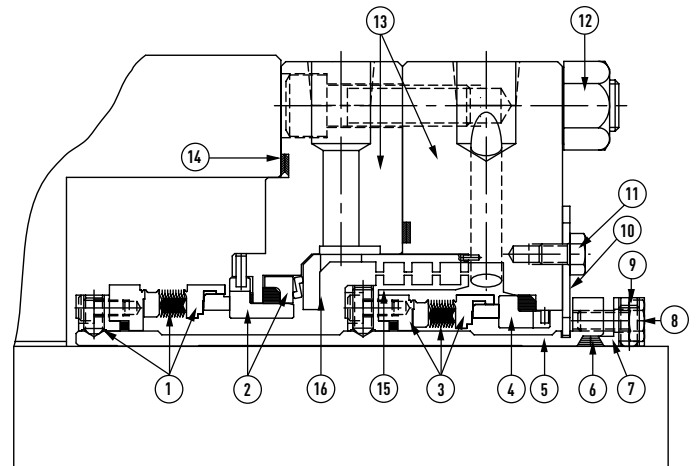



1604HTC/2609HTC/ 3609HTC/2609HTL/3609HTL

SEAL SYSTEMS

Installation, Operation & Maintenance Instructions

PREPARING THE EQUIPMENT

1. Check the seal chamber dimensions and finishes.

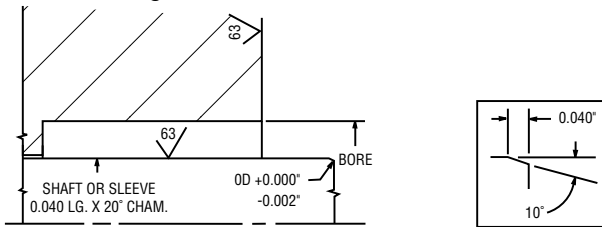

2. Measure axial end play (0.005"/0.13mm FIM max.).

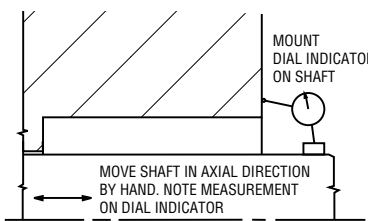

3. Determine squareness of seal chamber face to shaft (0.001" per inch/0.001mm per mm of shaft diameter FIM max.), and shaft concentricity to the seal chamber.

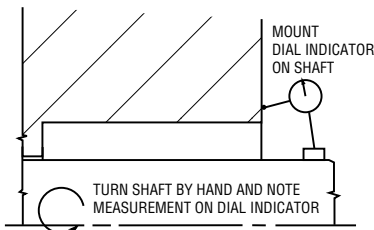

4. Measure shaft runout (0.001mm per mm/0.001" per inch of shaft diameter FIM max.).

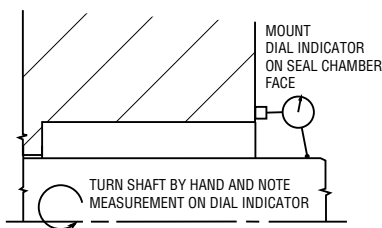

NOTE: If measured dimensions exceed those values given, correct the equipment to meet specifications prior to seal installation.

Installing the seal in an overhung pump

1. Disassemble the seal chamber housing. Wipe the shaft/sleeve clean. Take the complete cartridge assembly from its package. Do not disassemble or alter the unit.
2. Slide the packing follower and sleeve packing as far as possible onto the shaft/sleeve, towards the bearings. Slide the complete cartridge assembly as far as possible onto the shaft/sleeve, towards the bearings. Reassemble the seal chamber housing and the impeller.

3. With the gland packing in place, slide the complete assembly into position against the face of the seal chamber. Assemble the gland bolts finger tight. Continue tightening alternately until secure. Do not distort the gland by overtightening.
4. Leave the locking washers or spacers in place to maintain the setting position of the cartridge seal.
5. If the assembly drawing calls for holes or countersinks to be drilled under the cartridge sleeve set screws, remove the set screws and mark their location. Unbolt the cartridge gland and remove the impeller, the seal chamber housing and the cartridge assembly. Drill the shaft/sleeve in the positions marked. Repeat steps 1-4.
6. Tighten the hex head cap screws to compress sleeve packing.
7. Tighten the cartridge sleeve set screws evenly. (If the shaft/sleeve has been drilled, ensure that the set screws align with the appropriate drilled holes).
8. Remove the locking washers/spacers, or rotate/slide the locking washer/spacer to clear the slot in the cartridge sleeve.
9. Complete reassembly of the pump, frequently turning the shaft by hand to check for free rotation. If the shaft will not turn, the seal has been improperly set.

ATTENTION Refer to assembly drawing and/or pump manual for piping connections and coupling alignment. Proceed as indicated.

Installing the seal between bearings

1. Disassemble the bearings and bearing housings. Take both complete cartridges from their packages. Do not disassemble or alter the units.
2. Slide the complete cartridge assemblies onto the shaft/sleeves, being careful not to damage the packings inside the cartridge sleeves. Slide the packing follower and sleeve packing as far as possible onto the shaft/sleeve.
3. Reassemble the bearing housings and bearings, and complete all required axial adjustments to the pump rotating assembly.
4. With the gland packing in place, slide the complete assembly into position against the face of the seal chamber. Assemble the gland bolts finger tight. Continue tightening alternately until secure. Do not distort the gland by overtightening.
5. Leave the locking washers or spacers in place to maintain the setting position of the cartridge seal.
6. If the assembly drawing calls for holes or countersinks to be drilled under the cartridge sleeve set screws, remove the set screws and mark their location. Unbolt the cartridge gland and remove the bearings, bearing housings, and cartridge assemblies. Drill the shaft/sleeves in the positions marked. Repeat steps 1-4.
7. Tighten the hex head cap screws to compress sleeve packings.
8. Tighten the cartridge sleeve set screws evenly. (If the shaft/sleeve has been drilled, ensure that the set screws align with the appropriate drilled holes).



1604HTC/2609HTC/ 3609HTC/2609HTL/3609HTL

SEAL SYSTEMS

Installation, Operation & Maintenance Instructions

9. Remove the locking washers/spacers, or rotate/slide the locking washer/spacer to clear the slot in the cartridge sleeve.
10. Complete reassembly of the pump, frequently turning the shaft by hand to check for free rotation. If the shaft will not turn, the seal has been improperly set.

ATTENTION Refer to assembly drawing and/or pump manual for piping connections and coupling alignment. Proceed as indicated.

Decommissioning the equipment

1. Ensure that the equipment is electrically isolated.



If the equipment has been used on toxic or hazardous fluids, ensure that the equipment is correctly decontaminated and made safe prior to commencing work. Remember, fluid is often trapped during draining and may exist outside the seal. The pump instruction manual should be consulted to check for any special precautions.

2. Ensure that the equipment is isolated by the appropriate valves. Check that the fluid is drained and pressure is fully released.

Maintenance

No maintenance of a seal is possible while installed. It is recommended that a spare seal unit and mating ring be held in stock to allow immediate replacement of a removed seal.

It is recommended that used seals be returned to a John Crane service location. Rebuilding to as-new specifications must be carried out by qualified personnel.



It is the responsibility of the equipment user to ensure that any parts being sent to a third party have appropriate safe handling instructions externally attached to the package.

Quality assurance

This seal has been assembled in accordance with John Crane quality assurance standards and with proper maintenance and use will give safe and reliable operation to the maximum recommended performance as shown in any relevant approved John Crane publication.

Ordering information

1. Cartridge seal size = solid shaft or sleeve outside diameter (OD).
2. For other material combinations or size considerations, consult the local John Crane representative.

Materials of construction

Description	Materials
Bellows:	Alloy 718
Adaptive Hardware:	300 series stainless steel
Faces:	Premium Grade Carbon, Tungsten Carbide Nickel Bound, or Silicon Carbide Reaction Bonded, Sealide-C*
Static Seals:	Flexible Graphite

Performance capabilities

Temperature:	Up to -100°F to 800°F/-75°C to 425°C
Pressure:	Up to 300 psig/20 barg
Speed:	Type 1604HTC: Up to 50 mps/10,000 fpm Type 2609HTC/3609HTC/2609HTL/3609HTL: Up to 25 mps/5,000 fpm



North America
United States of America
Tel: 1-847-967-2400

Europe
United Kingdom
Tel: 44-1753-224000

Latin America
Brazil
Tel: 55-11-3371-2500

Middle East & Africa
United Arab Emirates
Tel: 971-481-27800

Asia Pacific
Singapore
Tel: 65-6518-1800

If the products featured will be used in a potentially dangerous and/or hazardous process, your John Crane representative should be consulted prior to their selection and use. In the interest of continuous development, John Crane Companies reserve the right to alter designs and specifications without prior notice. It is dangerous to smoke while handling products made from PTFE. Old and new PTFE products must not be incinerated. ISO 9001 and ISO14001 Certified, details available on request.