

Low Temperature Design

- A – Spacer Ring
- B – Compression Ring
- C – Retaining Ring
- D – Wave Spring
- E – O-ring
- F – Vent/Drain Connection
- G – Seat/Mating Ring
- H – Insert
- I – Bellows Assembly
- J – Housing
- K – Spacer

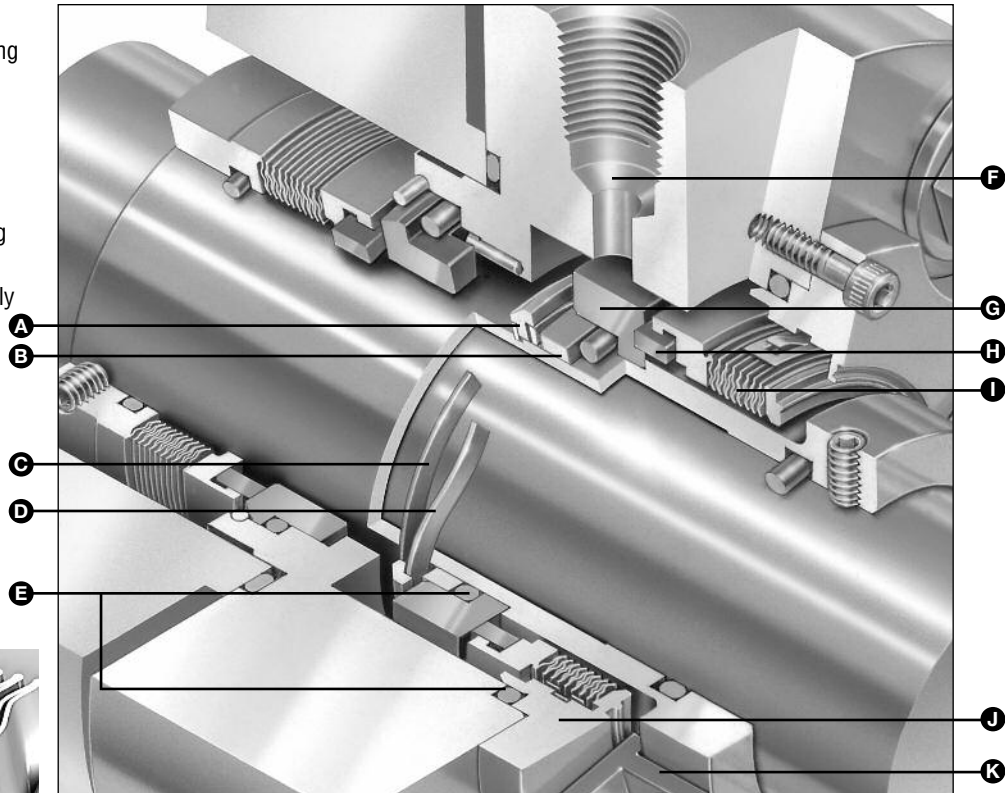

Welded Metal Bellows

Product Description

The Type ECS is a dry-running seal for emission containment and safety/back-up.

- An effective solution in meeting emission requirements while eliminating the need for liquid barrier systems
- Contain any nominal leakage from the primary seal and acts as a backup providing an additional level of safety during process or system upsets
- As a self-contained cartridge, the outer ECS is used with either a rotating or stationary John Crane primary seal of a bellows or pusher design

Design Features

- Successfully controls volatile organic compound (VOC), and volatile hazardous air pollutant (VHAP) emissions
- Available in low and high temperature designs
- Optimized tribopair ensures long-life with low face wear and heat generation
- Stationary mounted, uniformly loaded bellows plates produce closely controlled seal face loads for extended and reliable performance

Performance Capabilities - Low Temp.

- Temperature: up to 204°C/400°F (depending on elastomer specified)
- Pressure:
 - dynamic containment (wet): up to 20 bar g/300 psig
 - static containment (wet and dry): up to 31 bar g/450 psig
 - dynamic (dry): up to 1 bar g/15 psig
- Speed: up to 25 m/s/5000 fpm (Consult John Crane for applications outside these limits.)
- End play/axial float allowance: 0.08mm/0.003"
- Shaft Runout: 0.001mm/0.001" FIM max. per mm/inch of shaft diameter
- Check basic pressure rating and performance capabilities of your appropriate primary seal selection

TYPE ECS SEAL

METAL BELLOWS DRY-RUNNING SECONDARY CONTAINMENT

Technical Specification

High Temperature Design

- A – Spacer Ring
- B – Retaining Ring
- C – Wave Spring
- D – Compression Ring
- E – Vent/Drain Connection
- F – Housing
- G – Seat/Mating Ring
- H – Ball Drive
- I – Bellows Assembly
- J – Packing
- K – Insert
- L – Spacer

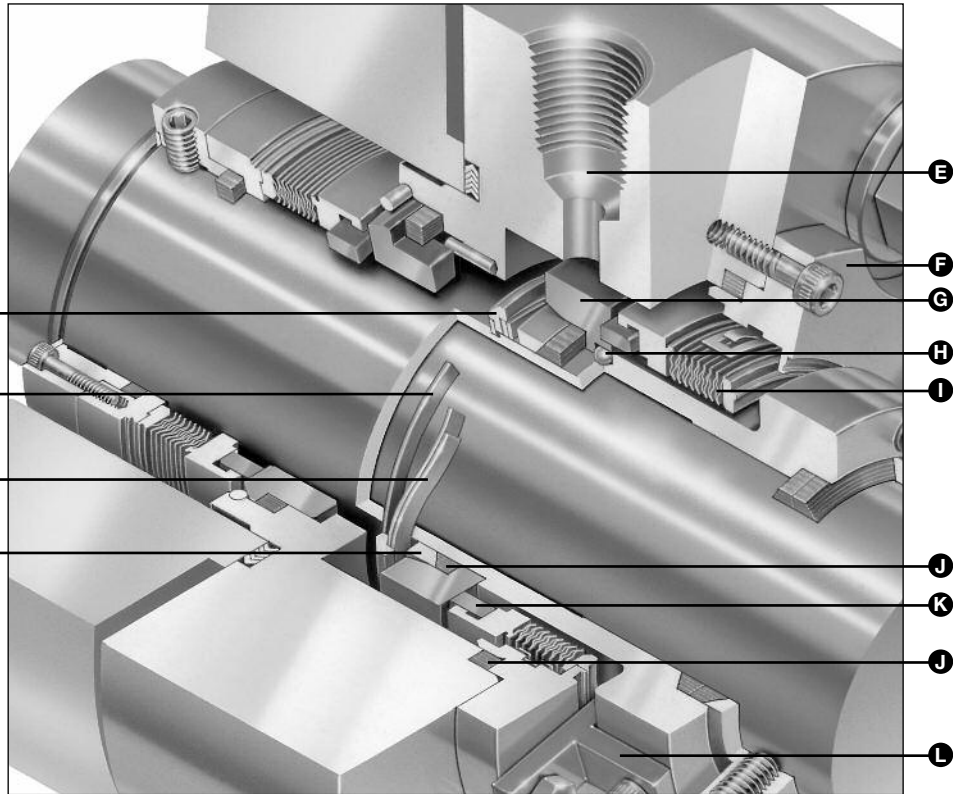

Performance Capabilities - High Temp.

- Temperature: up to 425°C/800°F
- Pressure:
 - dynamic containment (wet): up to 20 bar g/300 psig
 - static containment (wet and dry): up to 31 bar g/450 psig
 - dynamic (dry): up to 1 bar g/15 psig
- Speed: up to 25 m/s/5000 fpm
- End play/axial float allowance: 0.08mm/0.003"
- Shaft runout: 0.001mm/0.001" FIM max. per mm/inch of shaft diameter.
- Check basic pressure rating and performance capabilities on your appropriate primary seal selection.

Design Features

- Utilizes flexible graphite secondary seals for high temperature applications.
- Positive ball drive distributes torsional stresses more evenly than other drive mechanisms.
- Constructed of Alloy 718 bellows for its high temperature, high strength and corrosion resistance capabilities.

Mating Ring Assembly – High Temp.

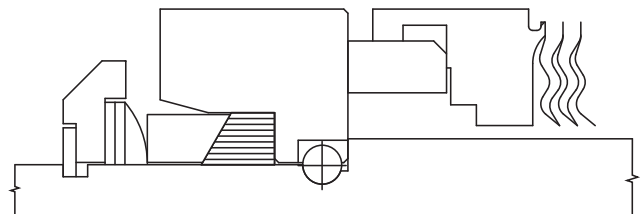

NOTE: One wave spring is used with perfluoroelastomer packing.

TYPE ECS SEAL

METAL BELLOWS DRY-RUNNING SECONDARY CONTAINMENT

Typical Low Temperature ECS Arrangement

Type 670 primary seal with
low temperature ECS outer seal

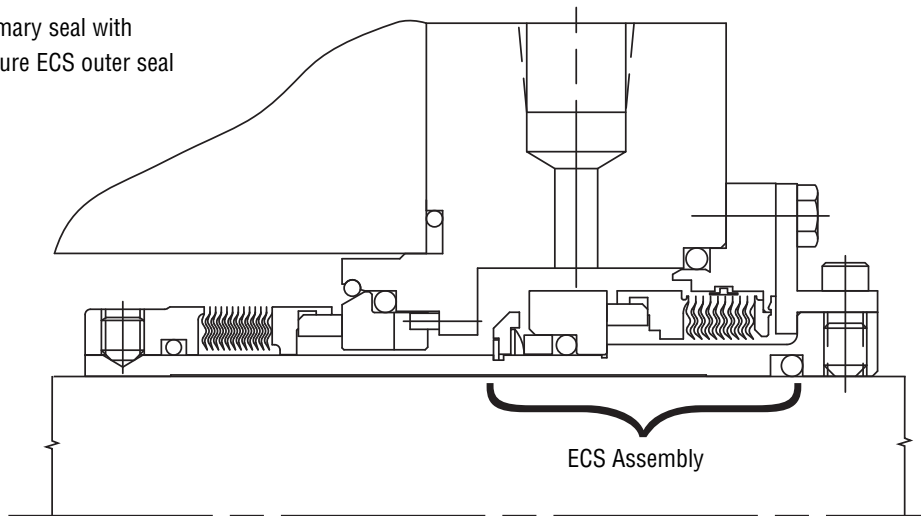

Typical High Temperature ECS Arrangements

Type 604 stationary primary seal
with high temperature ECS outer seal

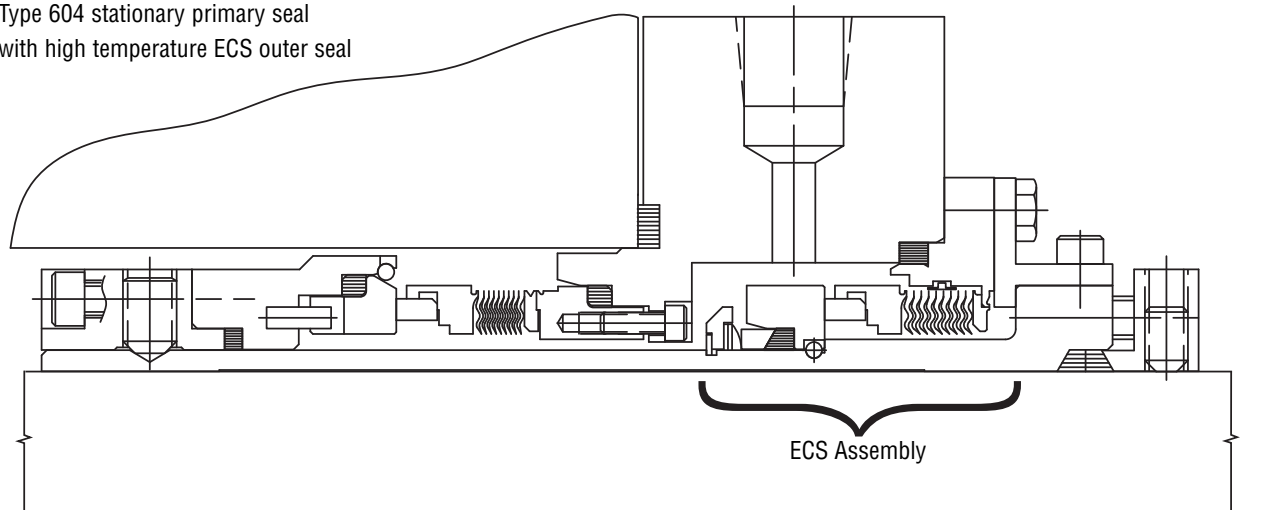

Type 609 rotating primary seal
with high temperature ECS outer seal

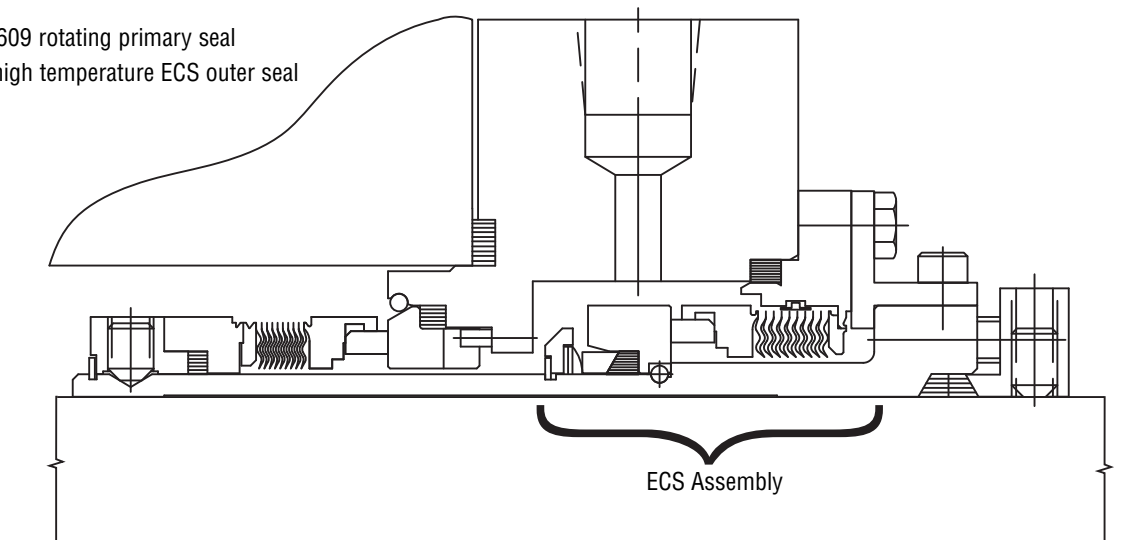

Materials of Construction - Low Temperature

SEAL COMPONENTS	MATERIALS	
	Description	Standard
Seat/Mating Ring	Silicon Carbide Reaction Bonded	—
Bellows	AM-350 (UNS S35000)	Alloy C-276 (UNS N10276) Alloy 718 (UNS N07718)
Insert	Special Carbon Grade	—
Packing	Fluorocarbon	Perfluoroelastomer
Wave Spring	17-7 pH Stainless Steel	—
Retaining Ring	302 Stainless Steel	—
Housing	316L Stainless Steel	—

Materials of Construction - High Temperature

SEAL COMPONENTS	MATERIALS	
	Description	Standard
Seat/Mating Ring	Silicon Carbide Reaction Bonded	—
Bellows	Alloy 718 (UNS N07718)	—
Insert	Special Carbon Grade	—
Packing	Flexible Carbon Graphite	Perfluoroelastomer
Wave Spring	17-7 pH Stainless Steel	—
Retaining Ring	302 Stainless Steel	—
Ball Drive	440 Stainless Steel	—
Housing	316L Stainless Steel	—

TYPE ECS SEAL

METAL BELLOWS DRY-RUNNING SECONDARY CONTAINMENT

Typical Piping Plans for Low Temperature ECS

Leakage from the primary seal is captured and sent to the flare or vapor recovery system in emission sensitive applications, or sent to a drain for collection in specific applications where leakage is in liquid form. If a nitrogen purge is used, the cavity pressure should not exceed 1 bar g/15 psig. Typically, nitrogen can be introduced at approximately 0.10 to 0.15 bar/1 to 2 psi greater than the flare or vapor recovery system pressure to further reduce potential emissions.

A pressure regulator is recommended when the flare or vapor recovery system can operate at a negative pressure. The pressure regulator will maintain a positive pressure in the outer seal cavity.

The following piping plans are recommended per API 682 Second Edition for emission containment seals.

API Plan 71

Typically this plan is used when a buffer gas may be used in the future.

- F = Flush
- GBI = Gas Buffer Inlet, plugged
- CSV = Containment Seal Vent, plugged
- CSD = Containment Seal Drain, plugged
- V = Vent

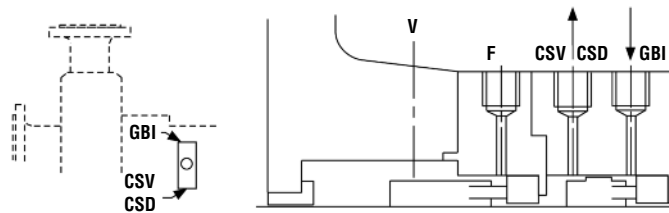

API Plan 72

Externally supplied gas buffer may be used alone to dilute seal leakage or in conjunction with Plan 75 or 76 to help sweep leakage into a closed collection system. Pressure of buffer gas is lower than process side pressure of inner seal.

- F = Flush
- GBI = Gas Buffer Inlet
- CSV = Containment Seal Vent
- CSD = Containment Seal Drain
- PI = Pressure Indicator
- FI = Flow Indicator
- V = Vent

When specified:

PCV = Pressure Control Valve, used to limit buffer gas pressure to prevent reverse pressurization of inner seal and/or limit pressure applied to containment seal.

FIL = Coalescing Filter, used to ensure solids and/or liquids which might be present in buffer gas supply do not contaminate seals.

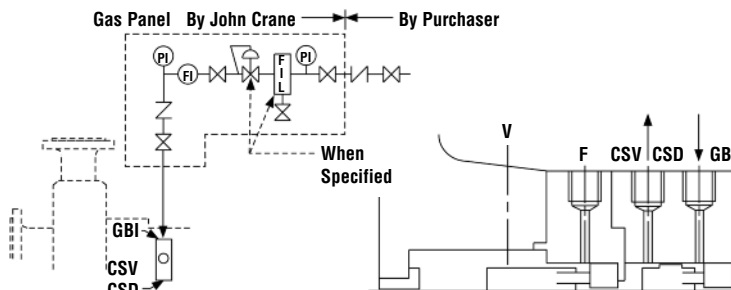

API Plan 75

Containment seal drain for condensing leakage. This plan is used when fluid condenses at ambient temperatures.

Valves to be installed per figure and must be accessible for operator use relative to ground clearance and other obstructions.

- F = Flush
- GBI = Gas Buffer Inlet
- CSV = Containment Seal Vent
- CSD = Containment Seal Drain
- LSH = Level Switch High
- PSH = Pressure Switch High
- V = Vent

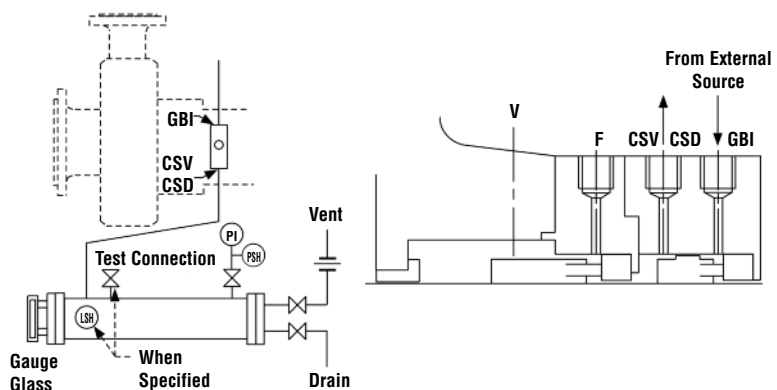

TYPE ECS SEAL

METAL BELLOWS DRY-RUNNING SECONDARY CONTAINMENT

Typical Piping Plans for Low Temperature ECS (continued)

API Plan 76

Containment seal chamber drain for non-condensing leakage. This plan is used when pumped fluid does not condense at ambient temperatures.

1 Tubing shall be 1/2" minimum in accordance with API 682 Auxiliary Piping Systems and shall rise continuously from the CSV connection to the piping/instrument harness.

2 Harness shall be 1/2" minimum pipe in accordance with API 682 Auxiliary Piping Systems. Harness shall be supported from overhead structure or side stand such that no strain is put on tubing connected to seal gland.

F = Flush

GBI = Gas Buffer Inlet

CSV = Containment Seal Vent

CSD = Containment Seal Drain

LSH = Level Switch High

PSH = Pressure Switch High

V = Vent

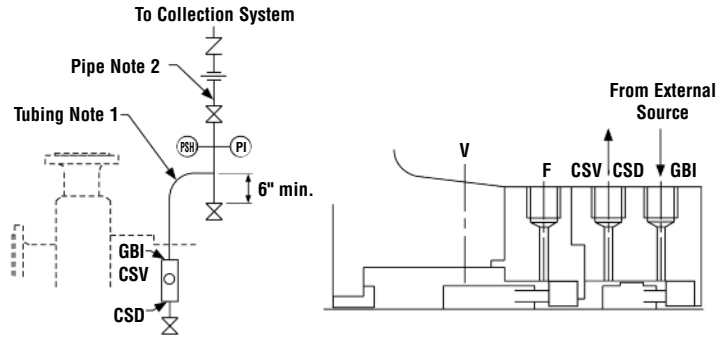

Typical Piping Plans for High Temperature ECS - Safety/Back-up Applications

If coking is a concern, continuously purging the ECS cavity with dry steam can be considered (injection pressures should be no more than 0.3 bar/5 psi).

F = Flush

GBI = Gas Buffer Inlet, plugged

CSV = Containment Seal Vent, plugged

CSD = Containment Seal Drain, plugged

V = Vent

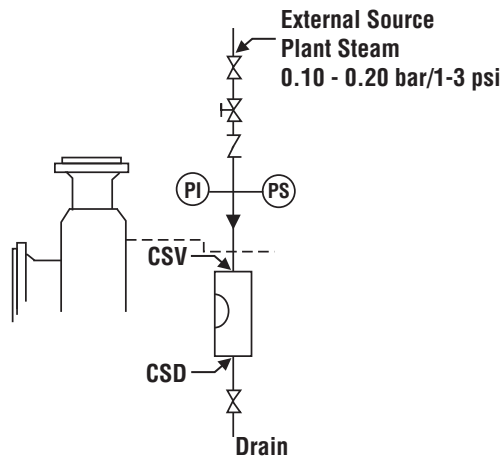
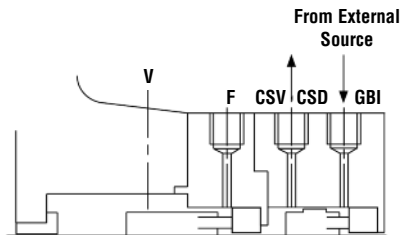

TYPE ECS SEAL

METAL BELLOWS DRY-RUNNING SECONDARY CONTAINMENT

TYPE ECS SEAL

METAL BELLOWS DRY-RUNNING SECONDARY CONTAINMENT

Technical Specification



North America
 United States of America
 Tel: 1-847-967-2400
 Fax: 1-847-967-3915

Europe
 United Kingdom
 Tel: 44-1753-224000
 Fax: 44-1753-224224

Latin America
 Brazil
 Tel: 55-11-3371-2500
 Fax: 55-11-3371-2599

Middle East & Africa
 United Arab Emirates
 Tel: 971-481-27800
 Fax: 971-488-62830

Asia Pacific
 Singapore
 Tel: 65-6518-1800
 Fax: 65-6518-1803

If the products featured will be used in a potentially dangerous and/or hazardous process, your John Crane representative should be consulted prior to their selection and use. In the interest of continuous development, John Crane Companies reserve the right to alter designs and specifications without prior notice. It is dangerous to smoke while handling products made from PTFE. Old and new PTFE products must not be incinerated. ISO 9001 and ISO14001 Certified, details available on request.