

# EAR DRIVE O-RING SEAL

## TYPE 5610V/5610VQ/5620VP

Technical Specification

- A – Face/Primary Ring
- B – Ear Drive Retainer
- C – Nonclogging Wave Spring
- D – Anti-Extrusion Ring  
(Only sizes above  
75mm / 3.000".)
- E – O-ring

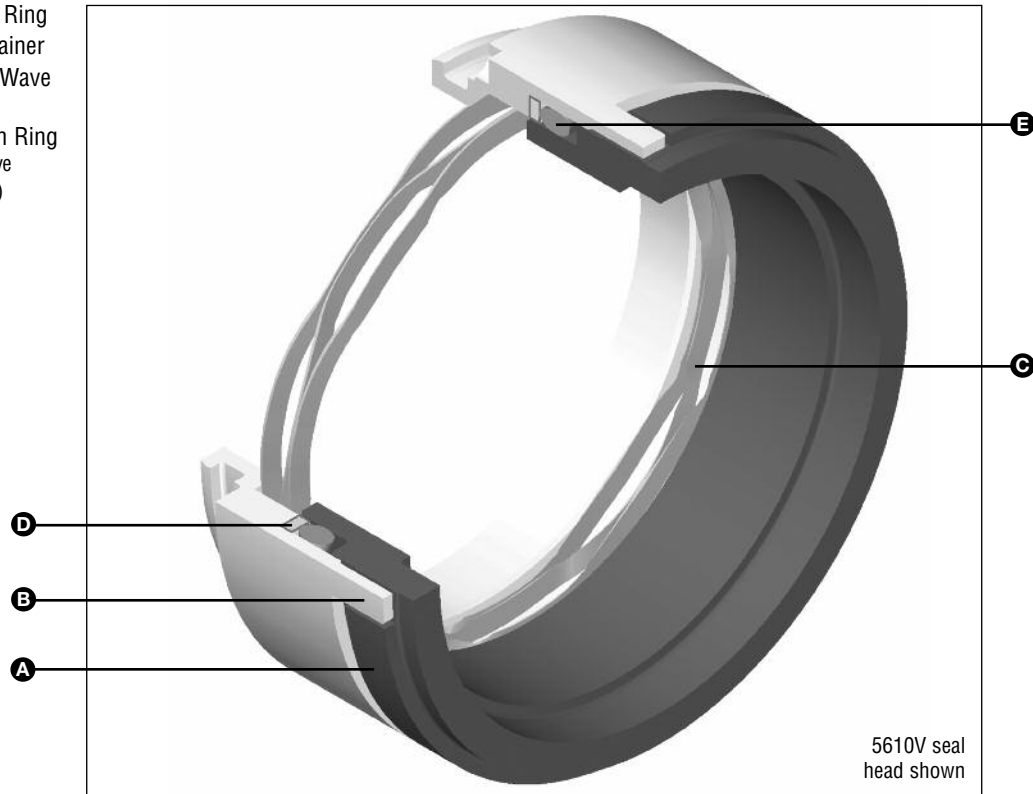

### Product Description

The specially engineered, fully interchangeable ear drive O-ring seal head extends the functionality of the 5600 series product line for standard ANSI and large bore pumps.

The Type 5610V is a single cartridge using the ear drive O-ring pusher seal head.

The Type 5610VQ is a single cartridge arrangement using the ear drive O-ring pusher seal head along with a quench gland containing a carbon ring throttle bushing.

The Type 5620VP is a dual cartridge arrangement using the ear drive O-ring pusher seal head.

### Performance Capabilities

- Temperature:  
-30°C to 205°C / -20°F to 400°F
- Pressure: up to 75mm / 3.000": 21 bar g/300 psig max.  
over 75mm / 3.000": 13 bar g/200 psig max.
- Speed: up to 25 m/s / 5000 fpm
- End play/axial float allowance: 0.13mm/0.005"
- Runout/out of squareness: 0.05mm/0.002"

### Design Features

- Ear driven primary ring ensures maximum seal life under a wider range of operating conditions
- Retrofits with existing 5600 seal heads
- Optimized primary ring design provides greater reliability
- Nonclogging wave spring is located outside of the product

# EAR DRIVE O-RING SEAL

TYPE 5610V/5610VQ/5620VP

Technical Specification

**Type 5610V**

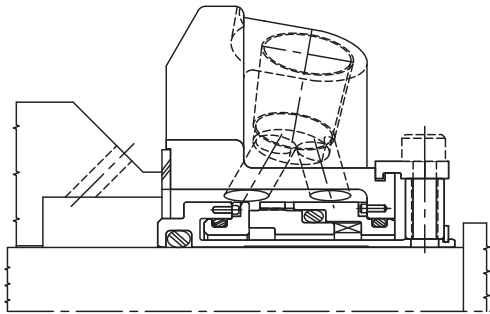

**Type 5620VP**

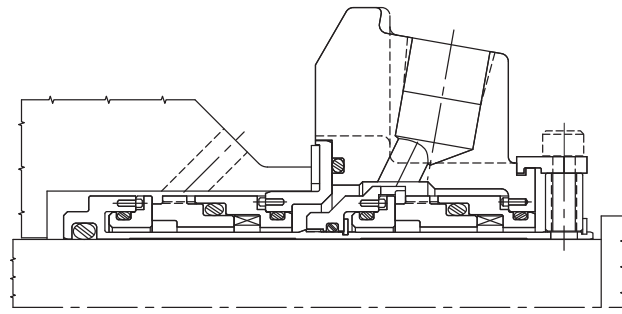

**Type 5610VQ**

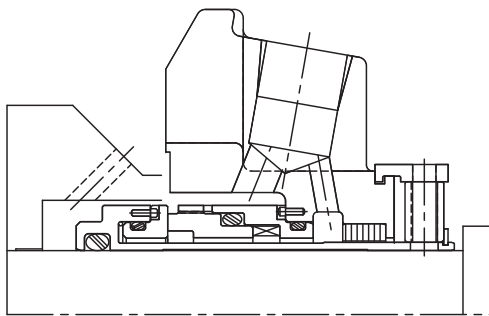

**Type 5610V Seal Head**



## Materials of Construction

SEAL COMPONENTS	MATERIALS	
	Standard	Options
Description		
Face/Primary Ring	Resin-Impregnated Carbon	Sintered Silicon Carbide Nickel Binder Tungsten Carbide
Retainer Anti-Extrusion Ring	316 Stainless Steel	Alloy 20CB3 SS (UNS N8020) Alloy C-276 (UNS N10276) Titanium
O-ring	Fluoroelastomer Ethylene Propylene	Perfluoroelastomer Buna-N Neoprene
Spring	Alloy C-276 (UNS N10276)	—



**North America**  
United States of America  
Tel: 1-847-967-2400  
Fax: 1-847-967-3915

**Europe**  
United Kingdom  
Tel: 44-1753-224000  
Fax: 44-1753-224224

**Latin America**  
Brazil  
Tel: 55-11-3371-2500  
Fax: 55-11-3371-2599

**Middle East & Africa**  
United Arab Emirates  
Tel: 971-481-27800  
Fax: 971-488-62830

**Asia Pacific**  
Singapore  
Tel: 65-6518-1800  
Fax: 65-6518-1803

If the products featured will be used in a potentially dangerous and/or hazardous process, your John Crane representative should be consulted prior to their selection and use. In the interest of continuous development, John Crane Companies reserve the right to alter designs and specifications without prior notice. It is dangerous to smoke while handling products made from PTFE. Old and new PTFE products must not be incinerated. ISO 9001 and ISO14001 Certified, details available on request.