

METAL BELLOWS SEAL

3604/3604HTC/3604HTCDP

Technical Specification

- A – Inner Bellows Assembly
- B – Primary Ring
- C – Packing
- D – Inner Mating Ring
- E – Flow Guide
- F – Spiral Wound Gasket
- G – Inner Gland
- H – Dual Scroll Pumping Device
- I – Outer Bellows Assembly
- J – Packing Follower
- K – Sleeve
- L – Outer Gland
- M – Outer Mating Ring
- N – Bushing
- O – Setting Spacer
- P – Mating Ring Retainer

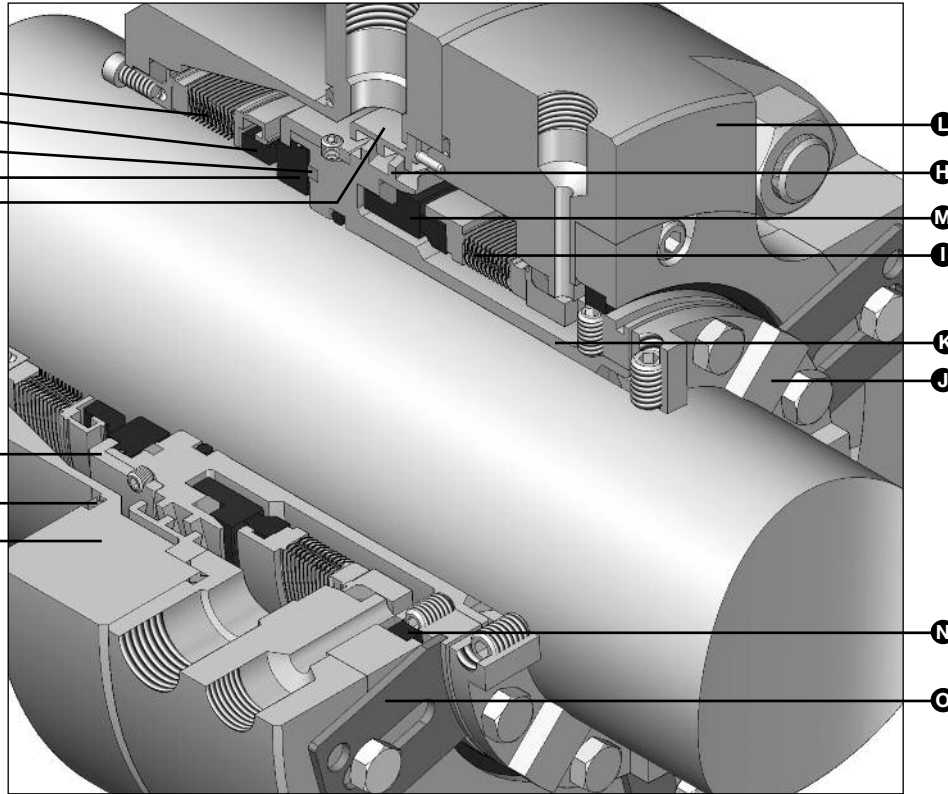

Welded Metal Bellows

Type 3604HTC

Product Description

- Type 3604 - Dual pressurized stationary bellows cartridge seal Type C, Arrangement 3. Type 604 stationary inner and outer seal
- Type 3604HTC - Dual pressurized stationary bellows cartridge seal Type C, Arrangement 3 that utilizes Type 604HTC technology
- Type 3604HTCDP - Dual pressurized stationary bellows cartridge seal Type C, Arrangement 3 that utilizes Type 604HTC double-ply technology for higher pressure applications

The Type 3604HTC and 3604HTCDP API 682/ISO 21049 cartridge seals utilize High-Temperature Corrosion Resistant (HTC) sealing technology for superior seal face stability at elevated temperatures. Enhanced seal face stability is achieved by minimizing thermal and mechanical forces that can contribute to seal face distortion extending your MTBR in many services.

A double-ply version is available that greatly improves pressure carrying capability to reliably seal demanding higher pressure applications in a face-to-face cartridge arrangement. A taper bore inner gland design is used to promote fluid movement and cooling around the inner seal face pair.

Stationary bellows designs are often used in high-temperature applications as they can accommodate high shaft-to-seal chamber misalignment. The design includes both a pressure retained and a positively retained inner mating ring which has the ability to handle higher reverse pressure conditions.

Performance Capabilities

- Temperature: -75°C to 425°C/-100°F to 800°F
- Pressure: single-ply: vacuum to 20 bar/300 psi
(Consult basic pressure rating curve)
double-ply: Vacuum to 42 bar/600 psi
(Maximum pressure rating can vary, consult John Crane Engineering for maximum double-ply pressure rating for your specific application)
- Speed: up to 50 m/s/10,000 fpm
- Shaft Size: 30mm to 110mm/1.5" to 4.33"

Design Features

- API 682/ISO 21049 qualified
- HTC technology. All-Inconel® metallurgy
- Stationary bellows design to accommodate high shaft-to-seal chamber misalignment
- Positively and pressure retained inner mating ring
- Sealide-C advanced silicon carbide composite
- ID and OD pressure capability - withstands reverse pressurization
- Internal dual scroll pumping device
- Carbon throttle bushing for effective containment
- Double-ply bellows for higher pressure applications
- Steam quench connection optional
- Tapered bore inner gland promotes fluid movement for enhanced cooling

METAL BELLOWS SEAL

3604/3604HTC/3604HTCDP

Typical Type 3604 API Type C Arrangement 3 - Dual Cartridge

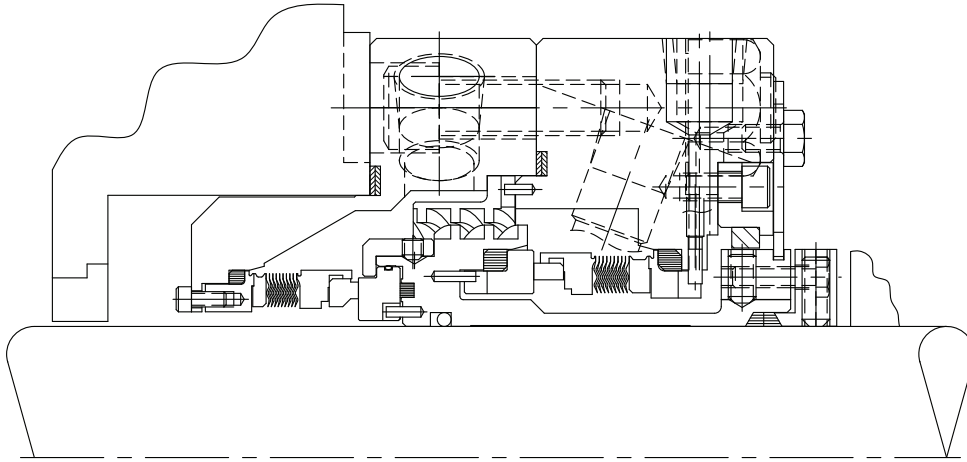

A dual stationary Type 3604 seal with Type 604 inner seal and Type 604 outer seal.

Typical Type 3604HTC/3604HTCDP API Type C Arrangement 3 - Dual Cartridge

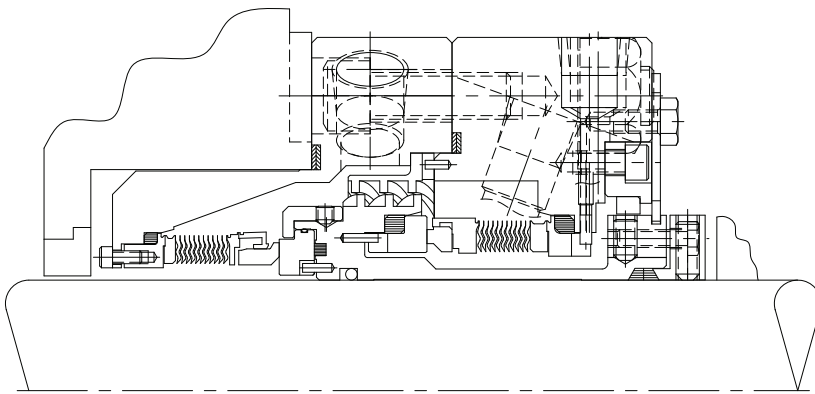

A dual seal with a Type 604HTC or 604HTCDP inner seal and Type 604 or 604DP outer seal. Typically used with API Plan 53(A, B, C).

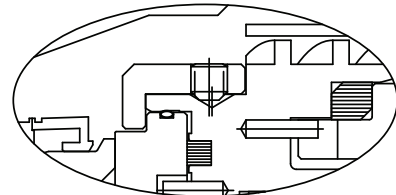

Retained Mating Ring for Reverse Pressure and Vacuum Service

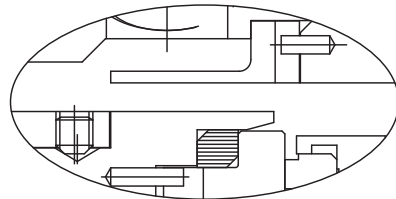

Non-internal circulation device arrangement. Typically used with API Plan 54.

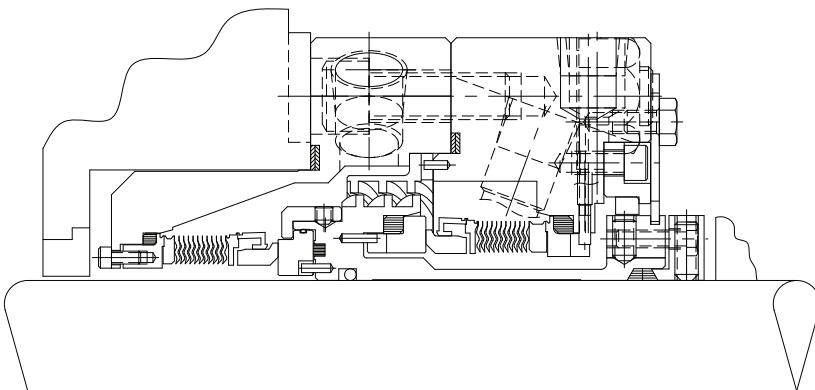

A dual seal with a Type 604HTC or 604HTCDP inner seal and Type 604HTC or 604HTCDP outer seal. Typically used with API Plan 53(A, B, C).

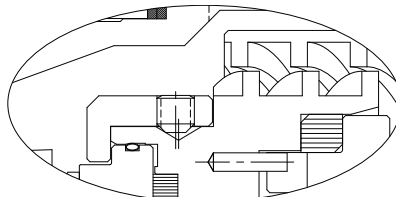

Dual Scroll Pumping Device

Basic Pressure Rating 3604HTC

Type 3604HTC OD Pressure Rating (Single-ply)

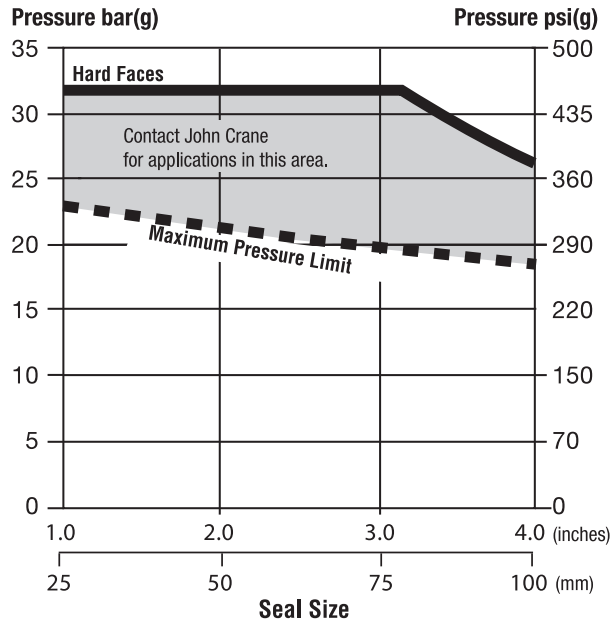

NOTES:

1. Basic pressure rating curve based on single-ply bellows.
2. Basic pressure rating curve is differential pressure applied to seal outside diameter.
3. Consult John Crane for double-ply pressure rating.

Type 3604HTC ID Pressure Rating (Single-ply)

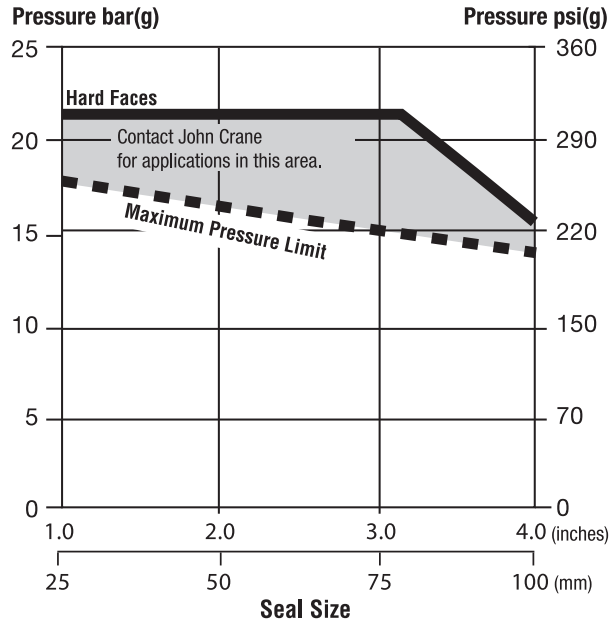

NOTES:

1. Basic pressure rating curve based on single-ply bellows.
2. For applications above 315°C/600°F and 13.8 barg/200 psig, consult John Crane.
3. For arrangement 3 seals, use differential pressure limits recommended in API 682/ISO 21049.
4. Consult John Crane for applications outside these limits and for double-ply pressure rating.

The basic pressure rating is for a standard seal, as shown in the typical arrangement, when installed according to the criteria given in this data sheet and generally accepted industrial practices.

The basic pressure rating assumes stable operation at 3600 rpm in clean, cool, lubricating non-volatile liquid with an adequate flush rate. When used with the Multiplier Factors, the Basic Pressure Rating can be adjusted to provide a conservative estimate of the dynamic pressure rating.

Contact John Crane for process services outside this range for a more specific assessment of the dynamic pressure rating. Contact John Crane for double-ply pressure rating.

Multiplier Factors

	Selection Considerations	Multiplier Factors SiC vs. SiC T/C vs. SiC
Speed	Up to 3600 rpm Above 3600 rpm	x 1.00 X (3600/speed)
Sealed Fluid Lubricity	Petrol/Gasoline, Kerosene, or Better Water and Aqueous Solutions (<80°C/176°F) Flashing Hydrocarbons (see Note 1)	x 1.00 x 0.75 (see Note 2)
Sealed Fluid Temperature (see Note 3)	Up to 80°C/175°F Up to 120°C/250°F Up to 205°C/400°F Up to 315°C/600°F Above 315°C/600°F	x 1.00 x 1.00 x 1.00 x 1.00 (see Note 4)

Example for Determining Pressure Rating Limits:

Seal: type 3604HTC

Size: 89mm/3.5" diameter

Product: high viscosity gas oil

Face material: sealide-c vs. silicon carbide

Operating temperature: 325°C/620°F

Operating speed: 3600 rpm

Example for determining dynamic pressure rating:

The maximum pressure for a particular application is the lesser of the maximum pressure limit curve or the pressure calculated when the multiplier factors are applied to the specific seal face material curve.

Maximum pressure limit curve:

19.5 barg/283 psig max. pressure

Hard face limit curve: 28 barg/406 psig

Calculated limit:

28 barg/406 psig x 1.00 x 1.00 = 28 barg/406 psig.

At 3600 rpm with the service conditions noted, an 89mm/3.5" Type 3604HTC has a maximum operating OD pressure limit of 19.5 barg/283psig.

*The ratio of sealed pressure to vapor pressure must be greater than 1.5, otherwise consult John Crane. If the specific gravity is less than 0.60, consult John Crane.

NOTES:

- Specific gravity ≥ 0.6 and ratio of sealed pressure to vapor pressure > 1.5 .
- More details regarding the fluid and the operating conditions are required.
- Temperature at the seal faces includes effects of flush, quench and cooling.
- Contact John Crane for more information.

Basic Pressure Rating 3604

Type 3604 OD and ID Pressure Rating (Single-ply)

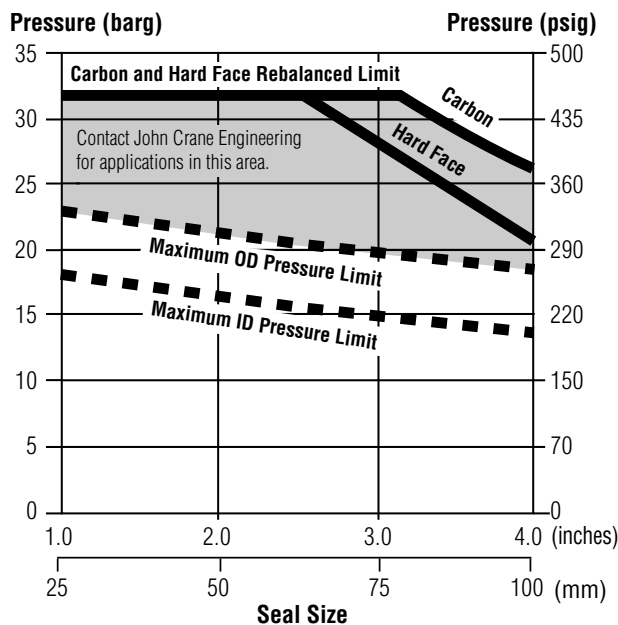

NOTES:

- Basic pressure rating curve based on single-ply bellows.
- For arrangement 3 seals, use differential pressure limits recommended in API 682/ISO 21049.
- Consult John Crane for applications outside these limits and for double-ply pressure rating.
- Refer to multiplier factors to determine pressure rating limits.

The basic pressure rating is for a standard seal, as shown in the typical arrangement, when installed according to the criteria given in this data sheet and generally accepted industrial practices.

The basic pressure rating assumes stable operation at 3600 rpm in clean, cool, lubricating non-volatile liquid with an adequate flush rate. When used with the multiplier factors, the basic pressure rating can be adjusted to provide a conservative estimate of the dynamic pressure rating.

Contact John Crane for process services outside this range for a more specific assessment of the dynamic pressure rating. Contact John Crane for double-ply pressure rating.

METAL BELLOWS SEAL

3604/3604HTC/3604HTCDP

Technical Specification

Materials of Construction 3604HTC and 3604HTCDP

SEAL COMPONENTS	3604HTC/3604HTCDP with TYPE 604 OUTER SEAL	3604HTC and 3604HTCDP with TYPE 604HTC OUTER SEAL
Description		
Inner Mating Ring	Silicon Carbide Reaction Bonded	Silicon Carbide Reaction Bonded
Inner Primary Ring	Sealide-C (Tungsten Carbide & Silicon Carbide Option)	Sealide-C (Tungsten Carbide and Silicon Carbide Option)
Inner Primary Ring Adapter	Alloy 718 (UNS N07718)	Alloy 718 (UNS N07718)
Inner Adapter	Alloy 718 (UNS N07718)	Alloy 718 (UNS N07718)
Outer Mating Ring	Silicon Carbide Reaction Bonded	Silicon Carbide Reaction Bonded
Outer Primary Ring	Premium Grade Carbon	Sealide-C (604HTC)
Outer Primary Ring Adapter	Alloy 42 (UNS K94100)	Alloy 718 (UNS N07718)
Outer Adapter	Alloy 625 (UNS N06625)	Alloy 718 (UNS N07718)
Bellows	Alloy 718 (UNS N07718)	Alloy 718 (UNS N07718)
Adaptive Hardware	316 Stainless Steel	316 Stainless Steel
Static Seals	Flexible Graphite	Flexible Graphite

Materials of Construction 3604

SEAL COMPONENTS	3604 SEAL	
Description	Standard	Options
Mating Ring	Silicon Carbide Reaction Bonded	—
Primary Ring Inner	Premium Grade Carbon	<ul style="list-style-type: none"> • Tungsten Carbide Nickel Bound • Silicon Carbide
Primary Ring Outer	Premium Grade Carbon	—
Primary Ring Adapter	Alloy 42 (UNS K94100)	—
Adapter	Alloy 625 (UNS N06625)	—
Bellows	Alloy 718 (UNS N07718)	—
Adaptive Hardware	316 Stainless Steel	—
Static Seals	Flexible Graphite	—

Double-ply Technology

John Crane double-ply bellows utilizes a laminated double-ply construction that greatly improves strength and pressure carrying capability with a relatively low spring rate.

The design principle can be illustrated by comparing it to the simple leaf spring. A spring comprised of a single, thick, metal member with the strength necessary to support a certain load would result in much too stiff a spring. But when the strength is obtained by using a "stack" of separate, individually flexing thin leaf elements, spring rate is well within desired limits.

John Crane combines the double-ply construction with our effective nesting ripple plate shape and 45° tilt angle capable of sealing demanding higher pressure applications.

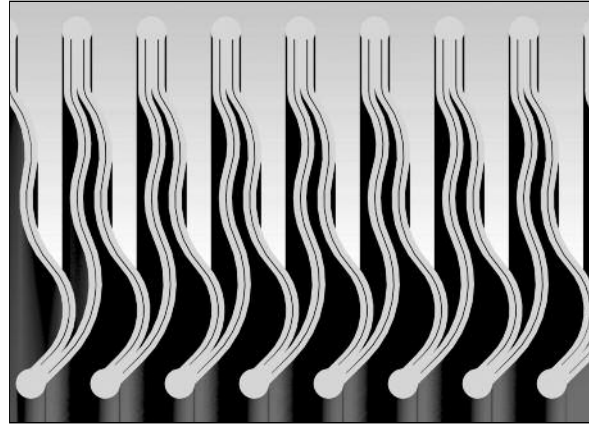

HTC Technology

The HTC seal provides an effective solution in sealing corrosive fluids at elevated temperatures by utilizing a complete all-Inconel® metallurgy and unique face seal technology that provides exceptional stability across a wide range of pressure/temperature conditions.

An effective means of ensuring seal reliability is by controlling seal face distortion, which directly affects the operating conditions at the sealing surface. The HTC incorporates pressure compensating seal faces and thermally compliant components that ensure exceptional seal face flatness stability that resists any compromising effects from temperature and pressure. Such exceptional face stability can result in reduced leakage and longer seal life.

In dual seal arrangements, this rugged seal is capable of handling reverse pressurization. In a dual unpressurized bellows arrangement, the primary seal is designed to contain a buffer reverse pressure. In a pressurized dual seal arrangement, the primary seal is normally operating with reverse barrier pressure and is designed to contain the process pressure in the event of loss of barrier pressure.

The HTC has proven to be a superior design for high temperature, corrosive applications up to 425°C/800°F.

Sealide-C Advanced Silicon Carbide Composite Primary Ring

Sealide-C is a state-of-the-art, sintered silicon carbide with low friction and the inherent lubricity of free graphite. This silicon carbide is a tough, hard, heat resistant, long wearing, inert seal face material. When compared with other face materials, Sealide-C provides improved corrosion resistance, improved thermal shock resistance, and lower running face temperatures.

Welded Metal Bellows

Design features:

- Optimum 45° tilt angle
- Three-sweep radius
- Nesting ripple plate design
- Static secondary seal
- Light spring loads

Bellows benefits:

- Uniform plate rigidity and stress distribution
- Enhanced fatigue strength
- Pressure-balanced by design
- Less Heat
- Lower power consumption

Inconel®

- Inconel® 718 nickel-chromium iron alloy is excellent for use in corrosive environments at elevated temperatures.
- This heat-treatable alloy retains excellent mechanical properties over a wide temperature range. Alloy 718 is utilized for the bellows plates and unique shell design and is the highest strength bellows material available.
- Meets NACE MR0175/MR0103 requirements.

Recommendations for Viscous Fluids

0 - 3500 cSt: Hard Face Material

3500 - 10,500 cSt: Consult John Crane

NOTE: SSU (Saybolt Universal Seconds) approximately equals cSt (centistoke)
 $\times 4.6347 \text{cP (centipoise)} = \text{cSt (centistoke)} \times \text{specific gravity.}$

Typical Applications

- Hydrocarbons
- Aromatic fractionation products (benzene, toluene, solvents, etc.)
- Crude oil fractionation products (fuel oil, lubricating oil, gasoline, etc.)
- Chemicals, caustics, some acids, aqueous solutions, lubricating liquids
- Heat transfer fluids

Angular and Radial Movement

Excessive runout will have a detrimental effect on seal performance in the form of component wear or excessive leakage.

API 682/ISO 21049 limits runout as follows:

- Centering of the seal is to be by a register fit. The register fit surface shall be concentric to the shaft and have a total indicated runout (FIM) of not more than 0.005"/125 micrometers
- Squareness of the seal chamber face to the shaft shall not exceed 0.0005" per inch of seal chamber bore (15 micrometers per cm)
- Runout of the sleeve outer diameter to the inner diameter shall be 0.001"/25 micrometers FIM
- Shaft-to-sleeve diametrical clearance shall be 0.001" to 0.003"/25 to 75 micrometers

Inconel is a registered trademark of Inco Alloys International, Inc.



North America	Europe	Latin America	Middle East & Africa	Asia Pacific
United States of America	United Kingdom	Brazil	United Arab Emirates	Singapore
Tel: 1-847-967-2400	Tel: 44-1753-224000	Tel: 55-11-3371-2500	Tel: 971-481-27800	Tel: 65-6518-1800
Fax: 1-847-967-3915	Fax: 44-1753-224224	Fax: 55-11-3371-2599	Fax: 971-488-62830	Fax: 65-6518-1803

If the products featured will be used in a potentially dangerous and/or hazardous process, your John Crane representative should be consulted prior to their selection and use. In the interest of continuous development, John Crane Companies reserve the right to alter designs and specifications without prior notice. It is dangerous to smoke while handling products made from PTFE. Old and new PTFE products must not be incinerated. ISO 9001 and ISO14001 Certified, details available on request.