

CARTRIDGE SPLIT SEALS



DESIGN BENEFITS

- Easy and fast installation
- Factory pre-built assembly
- Pressure-balanced primary ring for increased pressure capability
- Reduces costly unscheduled outages
- Extends operational life of your equipment

PRODUCT DESCRIPTION

■ ■ ■ ■ We know the challenges you face in maintaining the reliability of your pumps and rotating shaft equipment. As a result, we developed the 3740 and 3740XL with your time, money, and man-power in mind. This wet-running split seal has been created for use in all cooling water, condensate vertical lift and wastewater pumps and equipment.

CARTRIDGE SPLIT SEALS

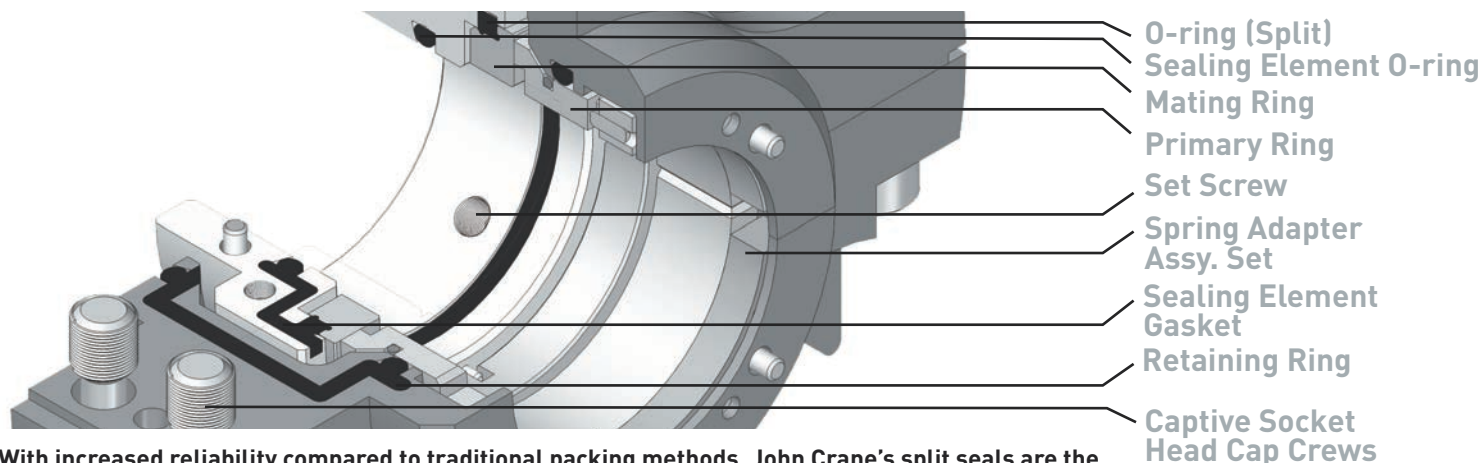

With increased reliability compared to traditional packing methods, John Crane's split seals are the answer. Without leakage from packing, bearing contamination and failure is significantly reduced, leading to increased equipment efficiency. Time-consuming packing adjustments are eliminated and lower frictional horsepower requirements reduce energy costs. The 3740XL can improve cost savings up to 66% over competitive split seals and 55% over packing.

Seal Type	Applications	Dry-running capability with large shaft run-out	Large Shaft Rotating Equipment (→ 6.000"/ 150mm)	Hard faces available for abrasive service	Suitable for field repair
3740	pumps			X	X
3740D	pumps, mixers, agitators	X			X
3740XL	large pumps, mixers, agitators, screw feeders, water turbines		X	X	X

PERFORMANCE CAPABILITIES

Seal Type	Pressure Limits	Speed Limits	Temperature Limits
3740	Excursion 450 psi(g)/131 bar(g) Continuously 300 psi(g)/20.7 bar(g)	Up to 3500 fpm/17.8 m/s	Up to 250°F/121°C
3740D	Vacuum to 80 psi(g)/5.5 bar(g)	400 fpm/2 m/s	275°F/135°C
3740XL	Up to 200 psi(g)/13.8 bar(g)	Up to 3500fpm/17.8m/s	Up to 250°F/121°C

Together, we will work with you to keep your mission-critical operations up and running, with support and guidance from our experienced team.



North America
United States of America
Tel: 1-847-967-2400
Fax: 1-847-967-3915

Europe
United Kingdom
Tel: 44-1753-224000
Fax: 44-1753-224224

Latin America
Brazil
Tel: 55-11-3371-2500
Fax: 55-11-3371-2599

Middle East & Africa
United Arab Emirates
Tel: 971-481-27800
Fax: 971-488-62830

Asia Pacific
Singapore
Tel: 65-6518-1800
Fax: 65-6518-1803

If the products featured will be used in a potentially dangerous and/or hazardous process, your John Crane representative should be consulted prior to their selection and use. In the interest of continuous development, John Crane Companies reserve the right to alter designs and specifications without prior notice. It is dangerous to smoke while handling products made from PTFE. Old and new PTFE products must not be incinerated. ISO 9001 and ISO 14001 Certified, details available on request.