

# TYPE 670/676/680

## LOW-TEMPERATURE METAL BELLOWS SEALS

Technical Specification

- A – Set screws
- B – Shaft packing
- C – Bellows assembly
- D – Insert/primary ring

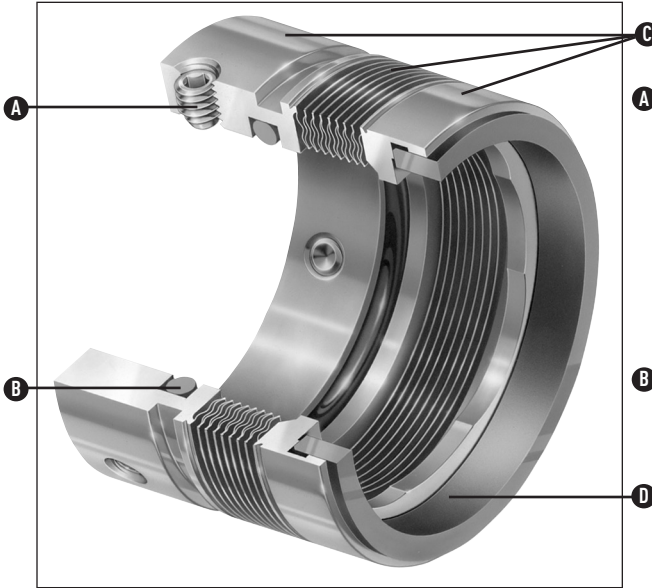

Type 680

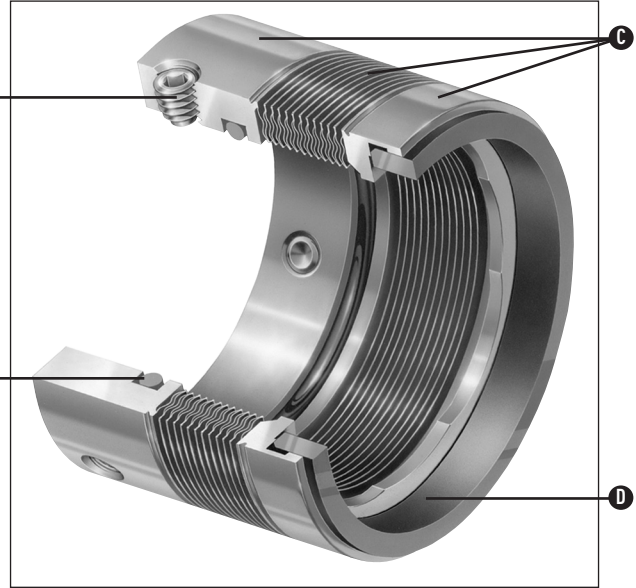

Type 670/676

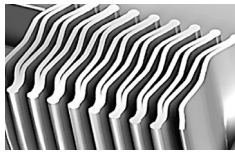

Sealol® Welded Metal Bellows

### Product Description

Type 670: All-alloy C-276 high-strength low-temperature bellows assembly for highly corrosive applications.

Type 676: AM350 low-temperature bellows assembly for large sizes and mildly corrosive applications.

Type 680: All-alloy 20 low-temperature high-performance seal for use on a broad range of corrosive media.

### Performance Capabilities

- Temperature: -75°C to +290°C/-100°F to +550°F  
(Depending on materials used)
- Pressure: Vacuum to 25 barg/360 psig  
(See basic pressure ratings curve)
- Speed: U-p to 25mps / 5,000 fpm

### Design Features

- Edge-welded metal bellows
- Static secondary seal
- Standard components
- Available in single or dual arrangements, shaft-mounted or in a cartridge
- The Type 670 meets API 682 requirements

### Typical Applications

- Acids
- Aqueous solutions
- Caustics
- Chemicals
- Food products
- Hydrocarbons
- Lubricating fluids
- Slurries
- Solvents
- Thermo-sensitive fluids
- Viscous fluids and polymers
- Water

# TYPE 670/676/680

## LOW-TEMPERATURE METAL BELLOWS SEALS

### Typical 670 with a Secondary Containment Seal Arrangement

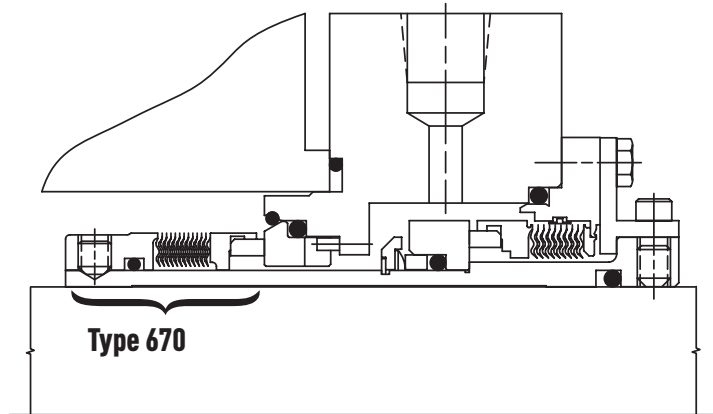

### Typical 676 Dual Cartridge Arrangement

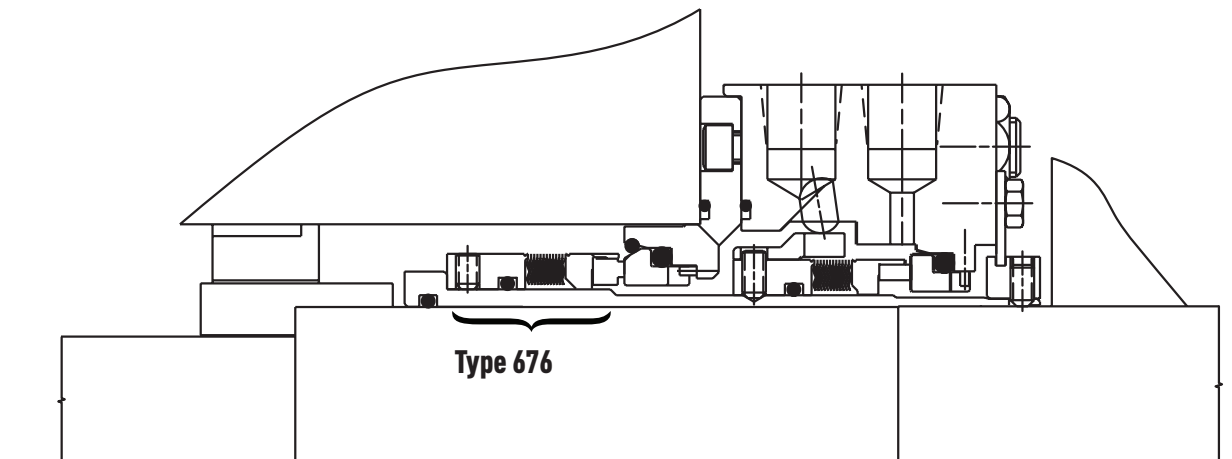

### Typical 680 Single Shaft-Mounted Arrangement

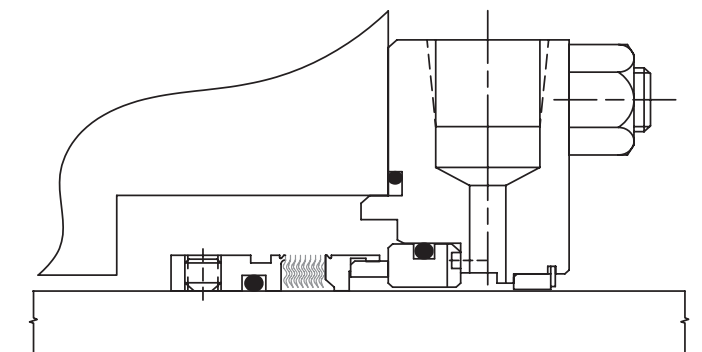

Type 680

# TYPE 670/676/680

## LOW-TEMPERATURE METAL BELLOWS SEALS

### Typical 670/676/680 Heads

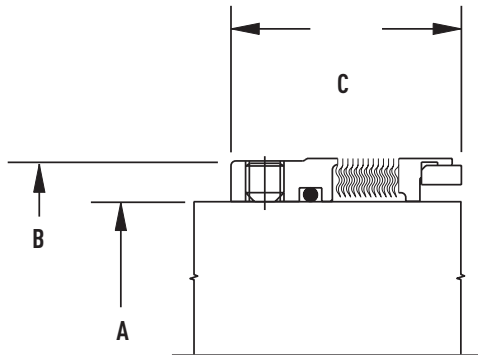

Type 670/676

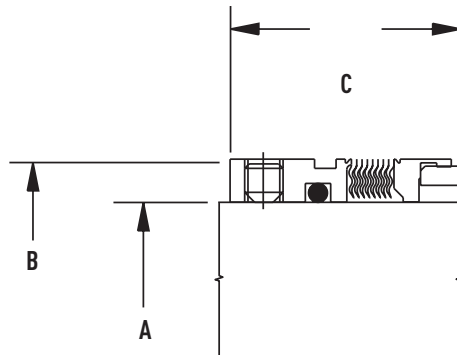

Type 680

### Type 670, 676, and 680 Metric Mounting Diameters

Seal Dash Number (Size Code)	A		B Ref.		C Ref.	
	+0.00 -0.05 (mm)	+0.000 -0.002 (in)	(mm)	(in)	(mm)	(in)
-018	18	0.709	32.00	1.260	27.50	1.083
-020	20	0.787	33.32	1.312	27.50	1.083
-022	22	0.866	36.00	1.417	27.50	1.083
-024	24	0.945	38.10	1.500	30.00	1.181
-025	25	0.984	39.00	1.535	30.00	1.181
-026	26	1.024	42.85	1.687	32.50	1.280
-028	28	1.102	42.00	1.654	32.50	1.280
-030	30	1.181	44.00	1.732	32.50	1.280
-032	32	1.26	46.02	1.812	32.50	1.280
-033	33	1.299	47.00	1.850	32.50	1.280
-034	34	1.339	49.20	1.937	32.50	1.280
-035	35	1.378	49.20	1.937	32.50	1.280
-038	38	1.496	52.37	2.062	34.00	1.339
-040	40	1.575	55.55	2.187	34.00	1.339
-042	42	1.654	58.72	2.312	34.00	1.339
-043	43	1.693	58.72	2.312	34.00	1.339
-044	44	1.732	58.72	2.312	34.00	1.339
-045	45	1.772	58.72	2.312	34.00	1.339
-048	48	1.89	61.90	2.437	34.00	1.339
-050	50	1.969	65.07	2.562	34.50	1.358
-052	52	2.047	68.25	2.687	34.50	1.358
-053	53	2.087	68.25	2.687	34.50	1.358
-054	54	2.126	68.25	2.687	34.50	1.358
-055	55	2.165	71.00	2.795	34.50	1.358
-058	58	2.283	74.60	2.937	39.50	1.555
-060	60	2.362	74.60	2.937	39.50	1.555
-062	62	2.441	80.95	3.187	39.50	1.555
-063	63	2.48	80.95	3.187	39.50	1.555
-065	65	2.559	84.12	3.312	39.50	1.555
-068	68	2.677	87.30	3.437	37.50	1.476
-070	70	2.756	87.30	3.437	45.00	1.772
-075	75	2.953	95.25	3.750	45.00	1.772
-080	80	3.15	98.43	3.875	44.50	1.752
-085	85	3.346	104.78	4.125	44.50	1.752
-090	90	3.543	107.95	4.250	49.50	1.949
-095	95	3.74	114.30	4.500	49.50	1.949
-100	100	3.937	120.65	4.750	49.50	1.949
-102	102	4.016	120.65	4.750	49.50	1.949
-105	105	4.134	131.75	5.187	48.33	1.903
-110	110	4.331	138.13	5.438	48.33	1.903
-115	115	4.528	144.48	5.688	48.33	1.903
-120	120	4.724	144.48	5.688	48.33	1.903
-125	125	4.921	150.83	5.938	48.33	1.903
-130	130	5.118	157.81	6.213	48.33	1.903
-140	140	5.512	170.54	6.714	48.33	1.903
-150	150	5.906	176.89	6.964	48.33	1.903

# TYPE 670/676/680

## LOW-TEMPERATURE METAL BELLOWS SEALS

### Typical 670/676/680 Heads

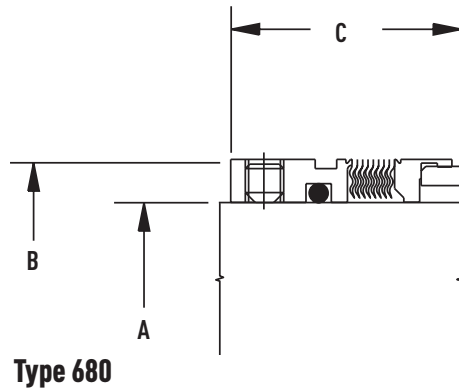
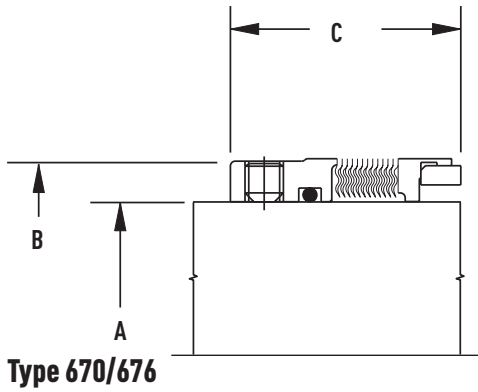

### Type 670, 676, and 680 Inch Mounting Diameters

Seal Dash Number (Size Code)	A		B Ref.		C Ref.	
	+0.00 -0.05 (mm)	+0.000 -0.002 (in)	(mm)	(in)	(mm)	(in)
-12	19.05	0.750	33.32	1.312	31.75	1.250
-14	22.23	0.875	36.50	1.437	31.75	1.250
-15	23.81	0.938	38.10	1.500	31.75	1.250
-16	25.40	1.000	39.67	1.562	31.75	1.250
-18	28.58	1.125	42.85	1.687	31.75	1.250
-20	31.75	1.250	46.02	1.812	33.32	1.312
-22	34.93	1.375	49.20	1.937	36.50	1.437
-24	38.10	1.500	52.37	2.062	36.50	1.437
-26	41.28	1.625	55.55	2.187	36.50	1.437
-28	44.45	1.750	58.72	2.312	36.50	1.437
-30	47.63	1.875	61.90	2.437	38.10	1.500
-32	50.80	2.000	65.07	2.562	38.10	1.500
-34	53.98	2.125	68.25	2.687	38.10	1.500
-36	57.15	2.250	71.42	2.812	39.67	1.562
-38	60.33	2.375	74.60	2.937	39.67	1.562
-40	63.50	2.500	80.95	3.187	39.67	1.562
-42	66.68	2.625	84.12	3.312	41.28	1.625
-44	69.85	2.750	87.30	3.437	41.28	1.625
-46	73.03	2.875	92.08	3.625	42.85	1.687
-48	76.20	3.000	95.25	3.750	42.85	1.687
-50	79.38	3.125	98.43	3.875	44.45	1.750
-52	82.55	3.250	101.60	4.000	44.45	1.750
-54	85.73	3.375	104.78	4.125	44.45	1.750
-56	88.90	3.500	107.95	4.250	47.63	1.875
-58	92.08	3.625	111.13	4.375	47.63	1.875
-60	95.25	3.750	114.30	4.500	47.63	1.875
-62	98.43	3.875	117.48	4.625	47.63	1.875
-64	101.60	4.000	120.65	4.750	47.63	1.875
-68	107.95	4.250	131.75	5.187	48.34	1.903
-72	114.30	4.500	138.13	5.438	48.34	1.903
-76	120.65	4.750	144.48	5.688	48.34	1.903
-80	127.00	5.000	150.83	5.938	48.34	1.903
-84	133.35	5.250	157.81	6.213	48.34	1.903
-88	139.70	5.500	164.16	6.463	48.34	1.903
-92	146.05	5.750	170.54	6.714	48.34	1.903
-96	152.40	6.000	176.89	6.964	48.34	1.903
-104	165.10	6.500	189.74	7.470	48.34	1.903
-108	171.45	6.750	196.11	7.721	48.34	1.903
-112	177.80	7.000	202.46	7.971	48.34	1.903

### Basic Pressure Rating

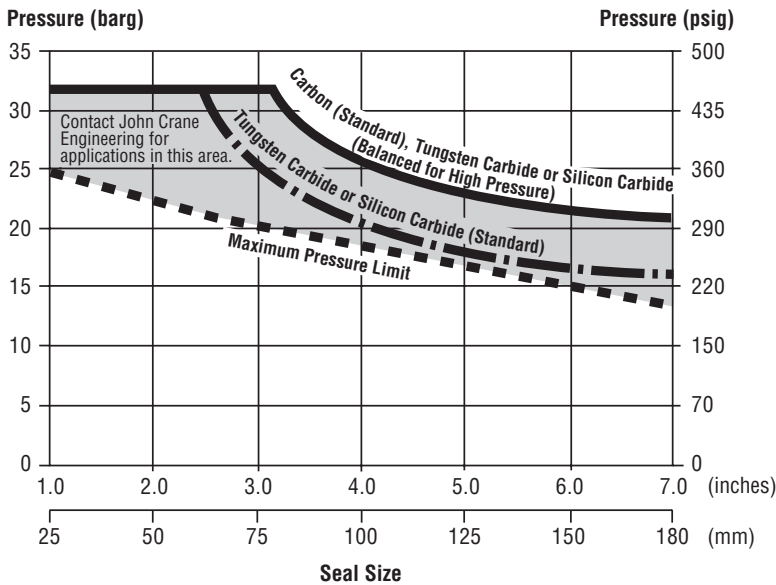

The basic pressure rating is for a standard seal, as shown in the typical arrangement, when installed according to the criteria given in this data sheet and generally accepted industrial practices.

The basic pressure rating assumes stable operation at 3,600 rpm in a clean, cool, lubricating, non-volatile liquid with an adequate flush rate. When used with the multiplier factors, the basic pressure rating can be adjusted to provide a conservative estimate of the dynamic pressure rating.

Contact John Crane for process services outside this range or a more specific assessment of the dynamic pressure rating.

**NOTES:**

1. Basic Pressure Rating Curve based on Single-Ply Bellows.
2. Basic Pressure Rating Curve is differential pressure applied to seal outside diameter.
3. Inside Diameter Differential Pressure vs. Temperature Limits: If the inside diameter differential pressure is greater than 6 barg/90 psig or the operating temperature is greater than 165°C/325°F, or seal size is greater than 100mm/4", consult John Crane Engineering.

### Multiplier Factors

	Selection Consideration	Multiplier Factors	
		Carbon vs. SiC	SiC vs. SiC
<b>Speed</b>	Up to 3,600 rpm	x 1.00	x 1.00
	Above 3,600 rpm	x (3,600/speed)	x (3,600/speed)
<b>Sealed Fluid Lubricity</b>	Petroleum/gasoline, kerosene, lube oil, etc.	x 1.00	x 1.00
	Water and aqueous solutions (< 80°C/176°F)	x 0.75	x 0.75
	Light hydrocarbons (see Note 1)	x 0.60	(see Note 2)
<b>Sealed Fluid Temperature</b> (see Note 3)	Up to 80°C/176°F	x 1.00	x 1.00
	Up to 120°C/250°F	x 0.85	x 1.00
	Up to 205°C/400°F	x 0.70	x 1.00

#### Example for determining pressure rating limits:

Seal: Type 680  
 Size: 50 mm/2"  
 Product: 50/50 glycol and water  
 Face material: carbon vs. silicon carbide  
 Operating temperature: 95°C/200°F  
 Operating speed: 3,600 rpm

#### Example for determining dynamic pressure rating:

The maximum pressure for a particular application is the lesser of the maximum pressure limit curve or the pressure calculated when the multiplier factors are applied to the specific seal face material curve.

#### Maximum pressure limit curve:

21 bar (g)/300 psi (g) max pressure  
 Carbon limit curve: 32 bar (g)/460 psi (g)  
 Calculated limit: 32 bar (g)/460 psi (g) x 1.00 x 0.75 x 0.85 = 20.2 bar (g)/293 psi (g)  
 At 3,600 rpm with the service conditions noted, a 50 mm/2.000" (seal size) Type 680 has a maximum operating pressure limit of 20.2 bar (g)/293 psi (g).

**NOTES:**

1. Specific gravity > 0.6 and ratio of sealed pressure to vapor pressure > 1.5.
2. More details regarding the fluid and the operating conditions are required.
3. Temperature at the seal faces includes effects of flush. Temperatures must not exceed limits shown in max. temperature limits section.
4. Contact John Crane for more information.

#### Maximum temperature limits:

Type 670: Carbon insert: 290°C/550°F  
 Tungsten carbide or silicon carbide: 200°C/400°F  
 Type 676: Carbon insert: 200°C/400°F  
 Tungsten carbide or silicon carbide: 190°C/375°F  
 Type 680: Carbon insert: 260°C/500°F  
 Tungsten carbide or silicon carbide: 150°C/300°F

### Materials of Construction

Description	Seal Components	Seal Types	Materials	
			Standard	Options
Bellows	Type 670	Alloy C-276 (UNS N10276)	—	
	Type 676	AM350 SS (UNS S35000)		
	Type 680	Alloy 20 (UNS N08020)		
End-fittings	Type 670	Alloy C-276	—	
	Type 676	316L SS (UNS S31603)		
	Type 680	Alloy 20		
Insert/primary ring		Premium carbon grade tungsten carbide, silicon carbide	—	
Static seals		Fluorocarbon, EPR, PTFE-encapsulated fluorocarbon, nitrile, perfluoroelastomer	—	

### Recommendations for Viscous Fluids

0 - 1,000 cSt: Standard seal

1,000 - 3,500 cSt: Hard face material

3,500 - 10,500 cSt: Consult John Crane Engineering

**NOTE:** SSU (Saybolt Universal Seconds) approximately equals cSt (centistoke)  $\times 4.6347$  cP (centipoise) = cSt (centistoke)  $\times$  specific gravity.

### Welded Metal Bellows

#### Bellows design features

- Optimum 45° tilt angle
- Three-sweep radius
- Nesting ripple plate design
- Static secondary seal
- Light spring loads

#### Bellows benefits

- Uniform plate rigidity and stress distribution
- Enhanced fatigue strength
- Pressure-balanced by design
- Less heat generated
- Lower power consumption

john crane

# TYPE 670/676/680

## LOW-TEMPERATURE METAL BELLOWS SEALS

Technical Specification

# TYPE 670/676/680

## LOW-TEMPERATURE METAL BELLOWS SEALS



North America	Europe	Latin America	Middle East & Africa	Asia Pacific
United States of America	United Kingdom	Brazil	United Arab Emirates	Singapore
Tel: 1-847-967-2400	Tel: 44-1753-224000	Tel: 55-11-3371-2500	Tel: 971-481-27800	Tel: 65-6518-1800
Fax: 1-847-967-3915	Fax: 44-1753-224224	Fax: 55-11-3371-2599	Fax: 971-488-62830	Fax: 65-6518-1803

If the products featured will be used in a potentially dangerous and/or hazardous process, your John Crane representative should be consulted prior to their selection and use. In the interest of continuous development, John Crane Companies reserve the right to alter designs and specifications without prior notice. It is dangerous to smoke while handling products made from PTFE. Old and new PTFE products must not be incinerated. ISO 9001 and ISO14001 Certified, details available on request.