

- A** – Seat/Mating Ring
- B** – Face/Primary Ring
- C** – Inboard Gland Plate
- D** – Sleeve
- E** – Outboard Gland Plate
- F** – Setting Clips
- G** – Drive Collar

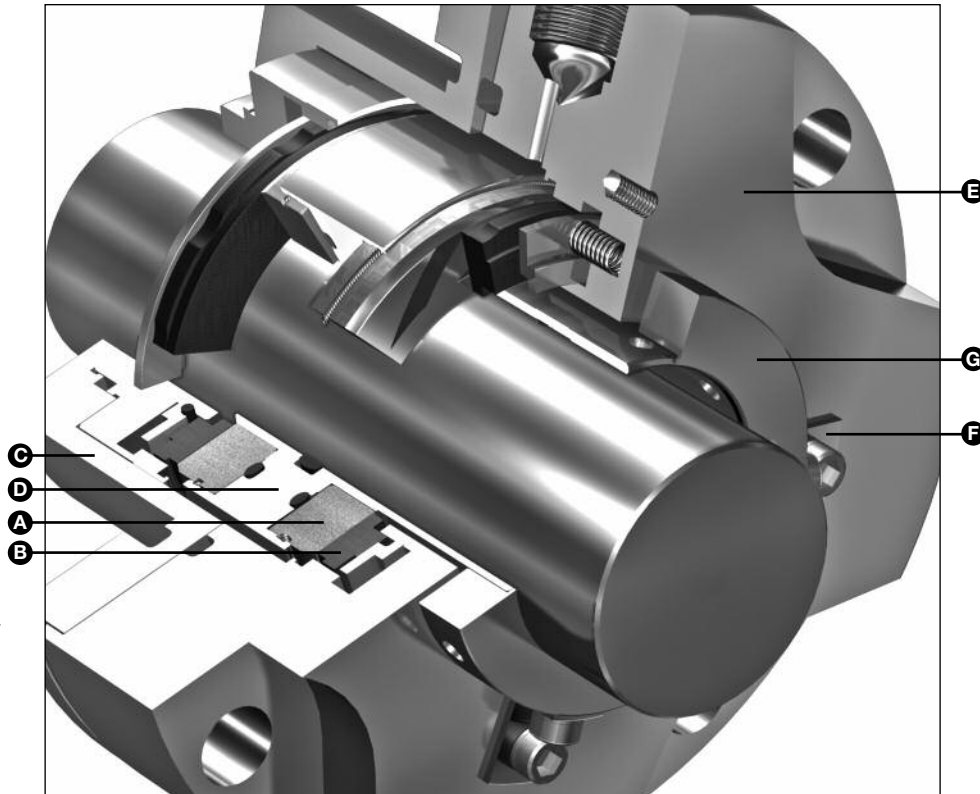

Spiral Groove Technology



Product Description

- Heavy duty, gas lubricated non-contacting dual seal where high differential pressures are encountered
- For use in large bore seal chambers
- Shaft sizes consistent with API 682
- For positive containment of volatile and hazardous fluids in chemical or petrochemical processes
- For high reliability sealing of high purity fluids with no potential for product contamination
- For sealing fluids that are sensitive to thermal gain or loss

Design Features

- Dual pressurized seal arrangement insures zero product emissions
- Reverse pressure capability insures full process containment
- Heavy duty seal faces and hardware to accept elevated pressure applications
- Inboard seal exhibits high differential pressure capability
- State of the art spiral groove, non-contacting seal face technology
- Non-contacting operation provides extremely low parasitic horsepower losses

Performance Capabilities

- Temperature: -40°F to 500°F/-40°C to 260°C
- Pressure: up to 600 psig/42 bar g max.
- Speed: 1,000 - 3,600 rpm
- * Conditions that vary from those listed above can be sealed using other Type 2800 series products. Consult John Crane.

Type 2800XP Highlights

The Type 2800XP is designed to deliver stable and reliable performance where high barrier pressures are required. The inboard seal embodies specific design elements intended to provide reliable and consistent barrier gas consumption in the presence of high differential pressure. Refer to the back page of this data sheet for stand-by pump piping and hot bypass recommendations.

TYPE 2800XP

GAS LUBRICATED NON-CONTACTING DUAL SEAL

Type 2800XP Typical Arrangement

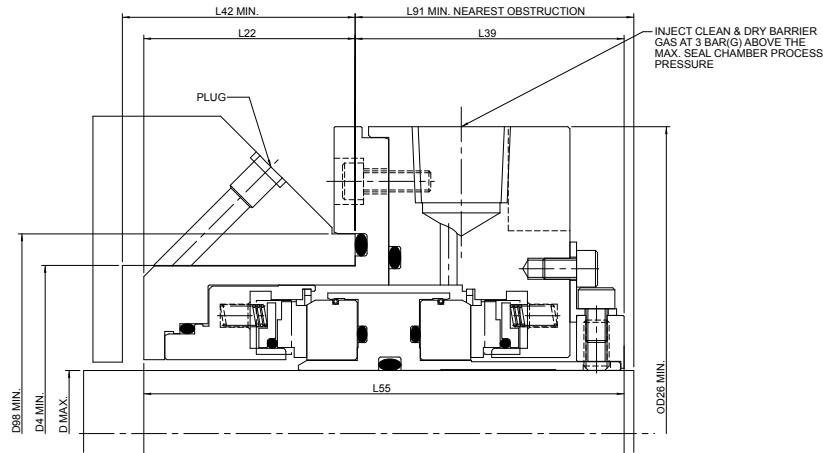

Type 2800XP Dimensional Data (mm)

Seal Size (mm)	D	D4	D26	L55	L39	L91	L42	L22	D98	Min. Stud. Dia.	Gland. Stud. PCD
						Min.	Min.	Inst. Ref.	Min.		
30mm	30.00	80.00	140.00	109.26	56.68	100.00	55.00	52.58	95.00	M12	115.00
38mm	38.00	76.20	139.70	109.75	57.63	60.63	55.12	52.12	95.20	M12	114.30
40mm	40.00	90.00	147.00	111.65	54.58	100.00	60.00	57.07	105.00	M12	125.00
43mm	43.00	88.90	165.10	116.15	66.33	69.33	52.82	49.82	110.24	M12	139.70
48mm	48.00	92.08	149.24	116.69	79.50	82.50	40.19	37.19	104.78	M12	127.00
50mm	50.00	100.00	166.00	115.05	64.98	110.00	55.00	50.07	115.00	M16	140.00
53mm	53.00	98.42	180.98	117.15	64.33	67.33	55.82	52.82	119.66	M16	152.40
60mm	60.00	120.00	185.00	115.37	56.30	110.00	60.00	59.07	135.00	M16	160.00
70mm	70.00	130.00	196.00	116.15	67.08	110.00	65.00	49.07	145.00	M16	170.00
80mm	80.00	140.00	206.00	118.17	71.80	110.00	70.00	46.37	155.00	M16	180.00
90mm	90.00	160.00	240.00	121.87	79.80	120.00	65.00	42.07	175.00	M20	205.00
100mm	100.00	170.00	248.00	117.87	74.80	120.00	70.00	43.07	185.00	M20	215.00
110mm	110.00	180.00	256.00	119.87	78.80	120.00	75.00	41.07	195.00	M20	225.00

Contact John Crane for other sizes.

Note: Seal sleeve dimensions are adjusted to accommodate imperial dimensions at D Max.

Cartridge Inboard gland plate dimensions are adjusted to accommodate D4 and D89 imperial dimensions.

Minimum stud diameter and gland stud PCD are adjusted to accommodate imperial equipment where necessary.

Seal Pressure Rating

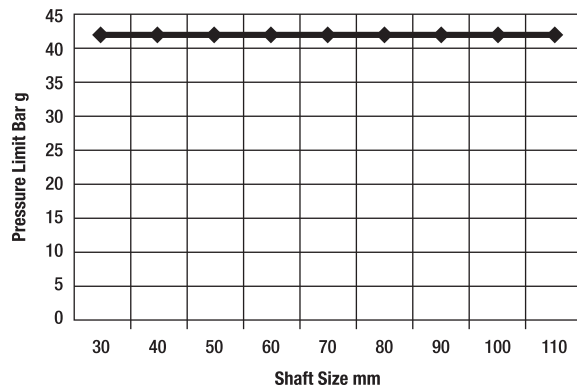

Barrier pressure must be set at a minimum of 43.5 psig/3 bar g above maximum seal chamber pressure.

TYPE 2800XP

GAS LUBRICATED NON-CONTACTING DUAL SEAL

Materials of Construction

SEAL COMPONENT	MATERIAL	CODE
PRIMARY RING – Standard – Options	Carbon	9028
	Carbon	9060
MATING RING – Standard – Options	Tungsten Carbide*	9205
	Silicon Carbide*	9221
O-RINGS – Standard – Options	Fluorocarbon	9549
	Perfluoroelastomer*	9579
	Nitrile	9501

*If required, 9580 and 3765 are also available.

SEAL COMPONENT	MATERIAL	CODE
SPRINGS – Standard	Stainless Steel	0550
OTHER		
TYPICAL HARDWARE – Gland plate – Sleeve – Drive Collar – Retainer – Thrust Ring	316 Stainless Steel	0550
– Options	Alloy C-276 (UNS N 10276)	0690
	Titanium	1955

Gas Control Panel

Instrumentation requirements which differ from the panel pictured can be accommodated. Contact John Crane.

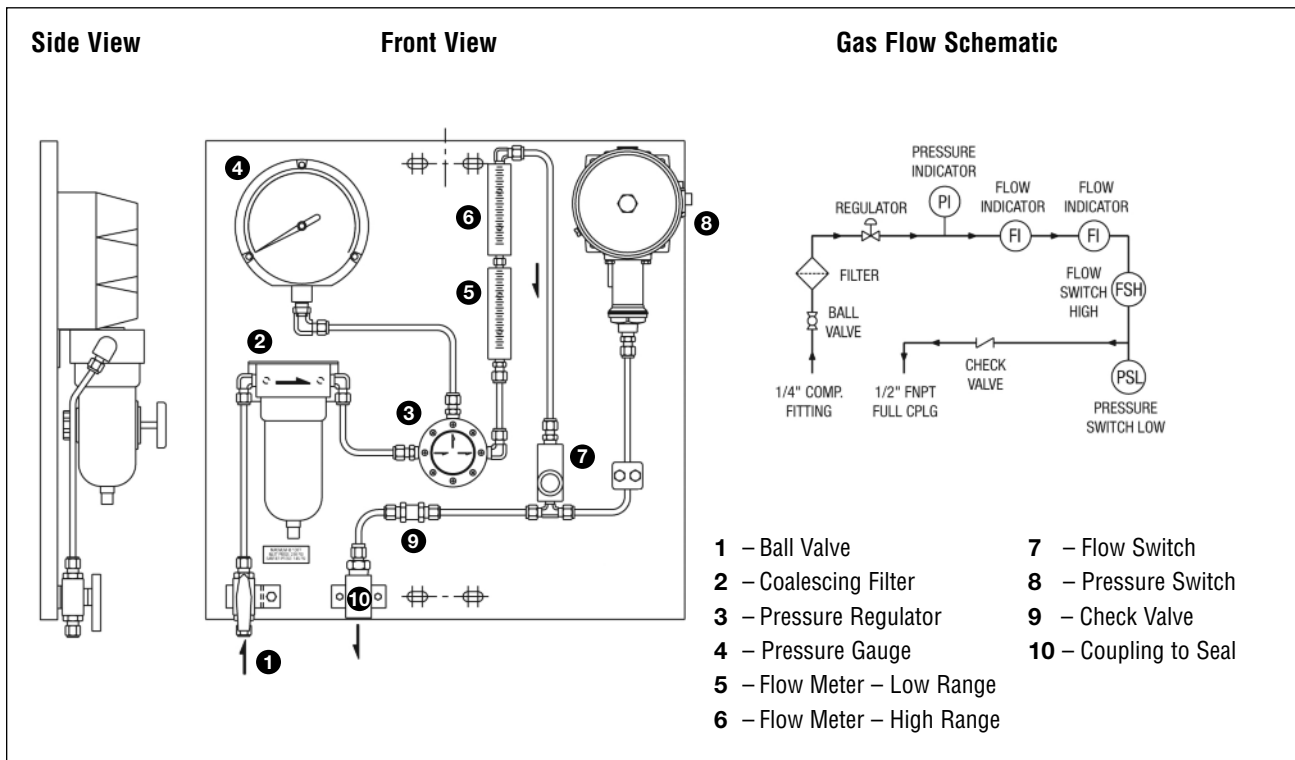

Gas consumption is dependent on barrier pressure, shaft speed, and may be affected by other application conditions. Contact John Crane for specific advice.

TYPE 2800XP

GAS LUBRICATED NON-CONTACTING DUAL SEAL

Piping Options for Hot Standby Pumps (also applies to Types 2874, 2874NE & 2800)

HOT BY-PASS FOR A STANDBY PUMP - OPTION 1

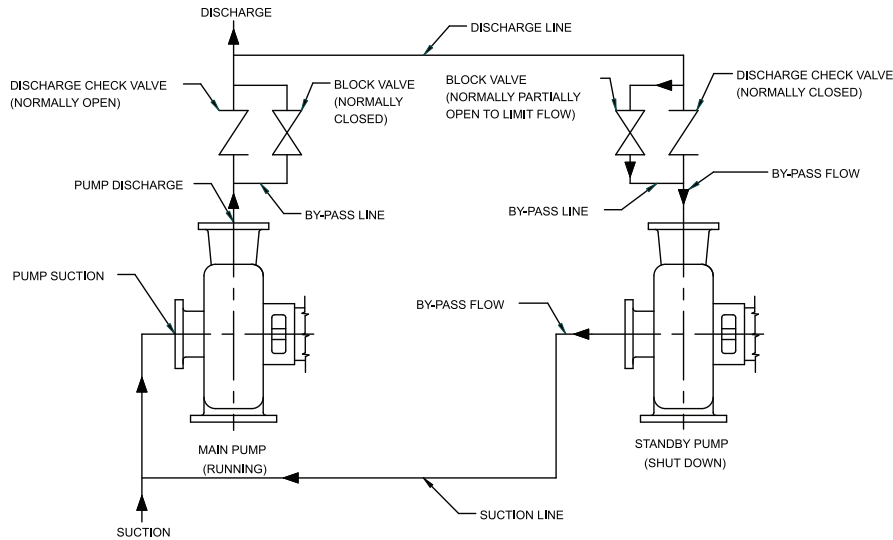

HOT BY-PASS FOR A STANDBY PUMP - OPTION 2

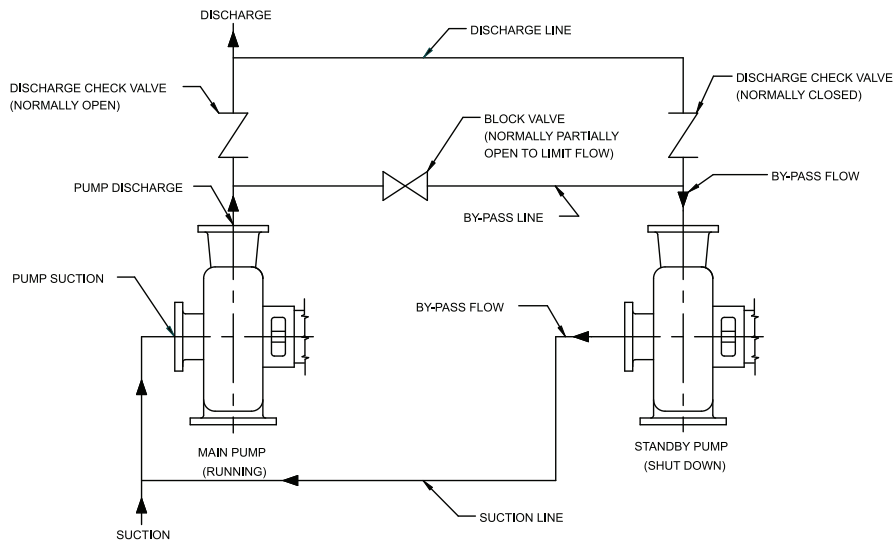

Often gas lubricated seals are installed on primary and standby pumps. Above are the recommended piping plans that allow standby pumps to manage barrier collection in static conditions. Both diagrams offer continuous circulation of pumped fluid in order to maintain temperature and avoid cavitation upon start-up of standby equipment. Detailed information and recommendations for specific applications are available from John Crane.



North America
United States of America
Tel: 1-847-967-2400
Fax: 1-847-967-3915

Europe
United Kingdom
Tel: 44-1753-224000
Fax: 44-1753-224224

Latin America
Brazil
Tel: 55-11-3371-2500
Fax: 55-11-3371-2599

Middle East & Africa
United Arab Emirates
Tel: 971-481-27800
Fax: 971-488-62830

Asia Pacific
Singapore
Tel: 65-6518-1800
Fax: 65-6518-1803

If the products featured will be used in a potentially dangerous and/or hazardous process, your John Crane representative should be consulted prior to their selection and use. In the interest of continuous development, John Crane Companies reserve the right to alter designs and specifications without prior notice. It is dangerous to smoke while handling products made from PTFE. Old and new PTFE products must not be incinerated. ISO 9001 and ISO14001 Certified, details available on request.