

## Foreword

This instruction manual is provided to familiarize the user with the seal and its designated use. The instructions must be read and applied whenever work is done on the seal, and must be kept available for future reference.

**ATTENTION** These instructions are for the installation and operation of a seal as used in rotating equipment. The instructions will help to avoid danger and increase reliability. The information required may change with other types of equipment or installation arrangements. This manual must be read in conjunction with the instruction manuals for both the pump and any ancillary equipment.

If the seal is to be used for an application other than that originally intended or outside the recommended performance limits, John Crane must be contacted before its installation and use.

Any warranty may be affected by improper handling, installation or use of this seal. Contact John Crane for information as to exclusive product warranty and limitations of liability.

If questions or problems arise, contact your local John Crane representative or the original equipment manufacturer, as appropriate.

**ATTENTION** John Crane mechanical seals are precision products and must be handled appropriately. Take particular care to avoid damage to lapped sealing faces and to flexible sealing rings. Do not excessively compress the seal before or during installation.

## Safety Instructions

1. The following designations are used in the installation instructions to highlight instructions of particular importance.

**NOTE** refers to special information on how to install or operate the seal most efficiently.

**ATTENTION** refers to special information or instructions directed toward the prevention of damage to the seal or its surroundings.



**Refers to mandatory instructions designed to prevent personal injury or extensive damage to the seal or its surroundings.**

2. Installation, removal and maintenance of the seal must be carried out only by qualified personnel who have read and understood these installation instructions.
3. The seal is designed exclusively for sealing rotating shafts. The manufacturer cannot be held liable for use of the seal for purposes other than this.
4. The seal must only be used in as-new condition, and must be operated within the recommended performance limits in accordance with its designated use and the instructions set out in these instructions.
5. If the pumped fluid is hazardous or toxic, appropriate precautions must be taken to ensure that any seal leakage is adequately contained. Further information on sealing hazardous or toxic fluids should be obtained from John Crane prior to seal installation.
6. Fluorocarbon components should never be burned or incinerated as the fumes and residues are highly toxic. If fluorocarbons are accidentally heated above 400°C/750°F, they can decompose. Protective gloves should be worn as hydrofluoric acid may be present.
7. PTFE components should never be burned or incinerated as the fumes are highly toxic.

## Before Starting the Equipment

1. Check the pump at the coupling for proper alignment of the driver or motor.
2. Ensure that the gland plate nuts/bolts are securely tightened according to the pump manual instructions, and all screws are securely fastened.
3. Complete the assembly of the pump and turn the shaft (by hand if possible) to ensure free rotation.
4. Consult all available equipment operating instructions to check for correctness of all piping and connections, particularly regarding seal recirculation/flush, heating or cooling requirements, and services external to the seal.

**ATTENTION** This mechanical seal is designed to operate in a liquid, so the heat energy it creates is adequately removed. The following check should be carried out not only after seal installation, but also after any period of equipment inactivity.

5. Check that the seal chamber fluid lines are open and free of any obstruction, and ensure that the seal chamber is properly vented and filled with liquid — refer to the pump instruction manual.

**ATTENTION** Dry-running — often indicated by a squealing noise from the seal area — will cause overheating and scoring or other damage to the sealing surfaces, resulting in excessive leakage or a much shortened seal life.



**Before start-up, ensure that all personnel and assembly equipment have been moved to a safe distance so there is no contact with rotating parts on the pump, seal, coupling or motor.**

#### WARNING

**Seal installation should be handled only by qualified personnel. If questions arise, contact the local John Crane representative. Improper use and/or installation of this product could result in injury to the person and/or harmful emissions to the environment, and may affect any warranty on the product. Please contact the company for information as to exclusive product warranty and limitations of liability.**

### Operating Conditions

The following are the operating limits of the 8648VRS seals. The selection of materials used in the construction of the seal should be made with regard to their temperature and chemical resistance/compatibility with the liquid being sealed.

**Temperature:** -4°F to 400°F/-20°C to 204°C

**Pressure:**  
Dynamic pressure:  
Up to 1500 psig/100 barg (crude)  
1,300 psig/90 barg (non-crude)  
Static pressure:  
Up to 2200 psig/152 barg (crude)  
2,000 psig/138 barg (non-crude)

**Speed:**  
5000 fpm/25.3 m/s (crude)  
6,000 fpm/31.5 m/s (non-crude)

### General Instructions

1. Be sure to read all instructions carefully before installing seal.
2. The John Crane 8648VRS seals are precision products and are shipped as completely assembled cartridge seals for ease of installation.

### Typical 8648VRS Seal Arrangement

- 1 – Primary ring
- 2 – Mating ring
- 3 – O-ring
- 4 – NPSS
- 5 – Retainer
- 6 – Drive band
- 7 – Stub sleeve
- 8 – Sleeve
- 9 – Seal vent
- 10 – Gland plate
- 11 – Collar

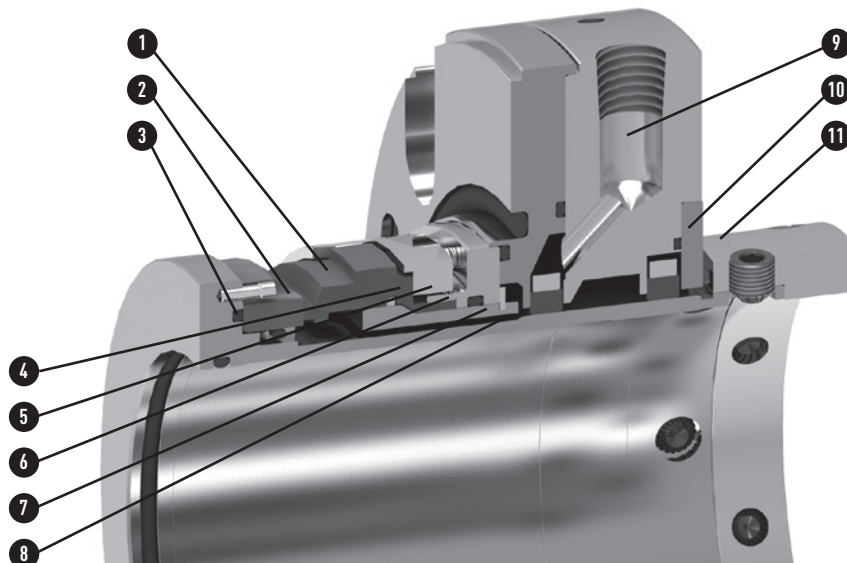

## 8648 VRS installation dimensions

For dimensional data on the seal installation, please refer to the specific John Crane layout drawing.

### Imperial/metric conversions:

- .060" x 20° = 1.6 mm x 20°
- 63V (µin) = 1.6V (µm)
- 0.005" = 125 micrometer
- 0.0005" per inch bore = 15 micrometer/3cm
- 0.001" = 25 micrometer

**NOTE** It is recommended that the pump and its installation meet the requirements of the latest edition of API Standard 610. Equipment that meets these requirements will aid in extending mean time between planned maintenance.

### Preparing the equipment

1. Check the shaft and seal chamber dimensions and finishes as noted. Check dimensions per specific John Crane layout drawing.

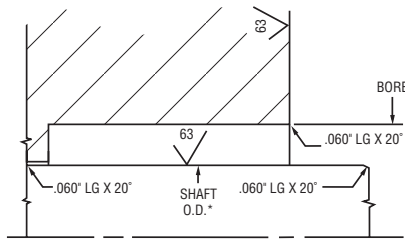

2. Measure the shaft end float/end play. The maximum value should not exceed 0.005" F.I.M.. Remove all sharp edges and burrs over which the seal sleeve must pass.

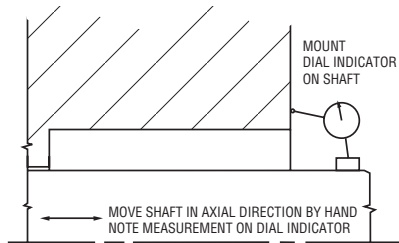

3. Check the squareness or face runout of the seal chamber face to the shaft. The maximum value should not exceed 0.0005" per inch of seal chamber bore diameter, F.I.M.

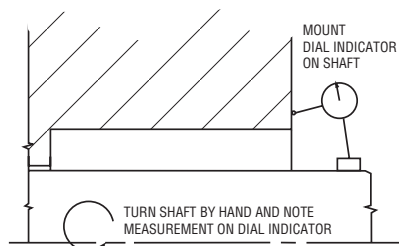

4. Measure the concentricity of the seal chamber bore to the shaft. This value should not exceed 0.005" F.I.M.

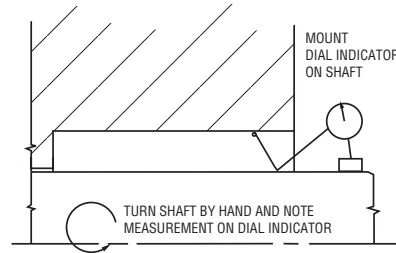

5. Measure the shaft runout at the seal location. The maximum value should not exceed 0.001" F.I.M.

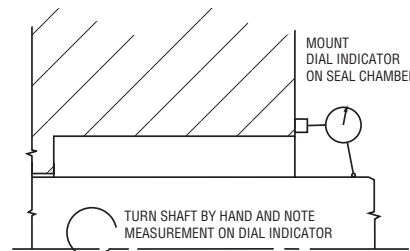

**NOTE** If the measured dimensions exceed these values given, correct the equipment to meet the specifications prior to installing the seal cartridge.

### Installing the seal

1. Before starting the installation, read through the following instructions carefully, as the sequence may be different depending on the construction of the pump.
2. Remove the seal from its packaging, inspect the seal for any damage and wipe clean.
3. The equipment should be clean and meet the specifications noted in "Preparing the Equipment". Check the sleeve and gland secondary seal. Apply a lubricant, if necessary, to assist in assembly. The gland plate nuts should be lubricated in order to achieve proper torque values.
4. The seal cartridge contains four (4) spacers that set the working height of the seal. On some equipment, the lower spacer is not accessible once the seal is installed onto the shaft. In these instances remove the lower spacer.
5. **For overhung pumps with single-row collar:** Check that the drive collar set screws are engaged in the sleeve holes without touching the shaft. Slide the seal cartridge onto the shaft as close to the nearest obstruction as possible. Position the gland plate so the flush connection, marked "F" is at or near top dead center. Install the seal chamber onto the pump and tighten the bolts to the bearing frame. Slide the seal cartridge onto the studs. Hand tighten the gland plate nuts.
5. **For between-bearing pumps with single-row collar:** Check that the drive collar set screws are engaged in the sleeve holes without touching the shaft. Slide the seal cartridge onto the shaft. Position the gland plate so the flush connection, marked "F", is at or near top dead center. Hand tighten the gland plate nuts.

6. **For between-bearing pumps with double-row collar:** Check that the drive collar set screws are engaged in the sleeve but do not protrude through the outer row threaded holes of the collar so as to touch the shaft during assembly. Slide the seal cartridge onto the shaft. Position the gland plate so the flush connection, marked "F", is at or near top dead center. Install the seal cartridge onto the studs. Hand tighten the gland plate nuts.
7. Reassemble the pump and make all necessary impeller adjustments.
8. Tighten the gland plate nuts in an alternating pattern until secure (1/4 turns, 180° apart), with gland plate and face of pump seal chamber metal to metal.
9. Check the gland/pump housing gap at each stud location to ensure even tightening. Tighten the outside lock collar set screws.
10. The collar can be rotated with the spacers intact. Once all the collar set screws are tightened, loosen the cap screws and rotate the spacer free of rotating parts. The spacer can be locked into place, out of the way of the collar, for future use, or removed and stored. Repeat the above for each spacer independently.
11. Use the spacers any time the gland nuts or collar set screws are loosened to properly set the seal to its working height.
12. Piping connections can now be made to the gland plate.

**WARNING:** Be sure to make the proper gland plate connections to the process and atmospheric sides of the seal.



The spacers must be positioned out of the way of the collar and tightened down prior to starting up the pump.

#### After the equipment has run

1. Ensure that the pump is electrically isolated.



If the equipment has been used on toxic or hazardous fluids, ensure that the equipment is correctly decontaminated and made safe prior to commencing work. Remember fluid is often trapped during draining and may exist outside the seal. The pump instruction manual should be consulted to check for any special precautions.

2. Ensure that the pump is isolated by the appropriate valves. Check that the fluid is drained and pressure is fully released.

#### Removing the Seal Cartridge

1. Referring to the pump installation manual, dismantle the equipment sufficiently to expose the gland plate and seal chamber.
2. **For overhung pumps with single-row collar:** Reinstall or rotate the spacer back into place over the collar and retighten the cap screws. Loosen the set screws in the collar. The set screws that engage the spacer need only be flush with the top of the spacer.

The remaining set screws should be loosened just enough so they still engage the sleeve drill-through holes. Evenly loosen and remove the gland plate nuts and carefully slide the plate off the studs. Remove the pump casing/seal chamber and the abutment or spacer when fitted, and then complete the removal of the seal cartridge in the reverse order of installation.

3. **For between-bearing pumps with single-row collar:** Reinstall or rotate the spacer back into place over the collar and retighten the cap screws. Loosen the set screws in the collar. The cap screws that engage the spacer need only be flush with the top of the spacer. The remaining set screws should be loosened just enough so they still engage the sleeve drill-through holes. Evenly loosen and remove the gland plate nuts and carefully slide the seal cartridge off the shaft.
4. **For between-bearing pumps with double-row collar:** Loosen the collar set screws and remove the collar. Remove the raised material on the shaft in the area of the set screws and replace the collar. Tighten the inner set screws onto the sleeve. Reinstall or rotate the spacer back into place over the collar and retighten the cap screws. Loosen or install the collar set screws that correspond to the spacer to be flush with the top of the spacers. Evenly loosen and remove the gland plate nuts and carefully slide the seal cartridge off the shaft.



The spacers need to be in place prior to seal assembly removal. Failure to install the spacers can result in damage to the seal faces.

#### Storage and Transport

1. Mechanical seal assemblies and component parts must be treated with extreme care to protect them from damage due to handling and deterioration. In all cases if established company procedures differ from the instructions provided in this document, the established procedures shall be followed.
2. Warehouse shelf storage:
  - a) John Crane mechanical seals and components are packaged to protect them from airborne dirt and grit, as well as from mishandling. If the packaging is removed for inspection, it should be replaced. Seals are generally packaged dry. Elastomer shelf life can be a factor if the storage period is in excess of two years.
  - b) If storage is in excess of one year, it is recommended that the primary and mating rings be inspected for flatness prior to installing the seals into the pump.
3. Storage of single seals in pumps:
  - a) If the mechanical seal is to be stored in the equipment, the seal cavity shall be drained of all water to prevent damage due to freezing temperature.
  - b) Any foreign matter should be removed as soon as possible after delivery of the pump on site. The open area between the gland plate and sleeve must be masked to exclude dirt after cleaning.
  - c) Cover pump suction and discharge flanges to exclude airborne debris.

- d) All open ports in the gland plate and seal chamber must be plugged with metal plugs.
- e) Seals that will be used on hydrocarbon based services can be fogged and filled approximately one-quarter (1/4) with a VPI oil. Alternately the seals can be preserved using an oil, or other suitable liquid, mist system.
- f) Mark and rotate the shaft several revolutions weekly. Leave the shaft 90° from the previous position.
- g) Seals in storage for more than two years should be disassembled to allow inspection of the primary and mating ring faces.

## Quality Assurance

This seal has been assembled in accordance with John Crane quality assurance standards and with proper maintenance and use will give safe and reliable operation to the maximum recommended performance as shown in any relevant approved John Crane publication.

## Maintenance

No maintenance of a seal is possible while installed. It is recommended that a spare seal unit and mating ring be held in stock to allow immediate replacement of a removed seal. It is recommended that used seals are returned to a John Crane service location, as rebuilding to as-new specifications must be carried out by qualified personnel.



**It is the responsibility of the equipment user to ensure that any parts being sent to a third party have appropriate safe handling instructions externally attached to the package.**



# 8648VRS SEAL

Installation, Operation & Maintenance Instructions

# 8648VRS SEAL



North America	Europe	Latin America	Middle East & Africa	Asia Pacific
United States of America	United Kingdom	Brazil	United Arab Emirates	Singapore
Tel: 1-847-967-2400	Tel: 44-1753-224000	Tel: 55-11-3371-2500	Tel: 971-481-27800	Tel: 65-6518-1800
Fax: 1-847-967-3915	Fax: 44-1753-224224	Fax: 55-11-3371-2599	Fax: 971-488-62830	Fax: 65-6518-1803

If the products featured will be used in a potentially dangerous and/or hazardous process, your John Crane representative should be consulted prior to their selection and use. In the interest of continuous development, John Crane Companies reserve the right to alter designs and specifications without prior notice. It is dangerous to smoke while handling products made from PTFE. Old and new PTFE products must not be incinerated. ISO 9001 and ISO14001 Certified, details available on request.