

TYPE 48LP/48HP

LOW EMISSION ELASTOMER O-RING SEALS

Technical Specification

- A – Seat/Mating Ring
- B – Face/Primary Ring
- C – Spring
- D – Sleeve
- E – Retainer

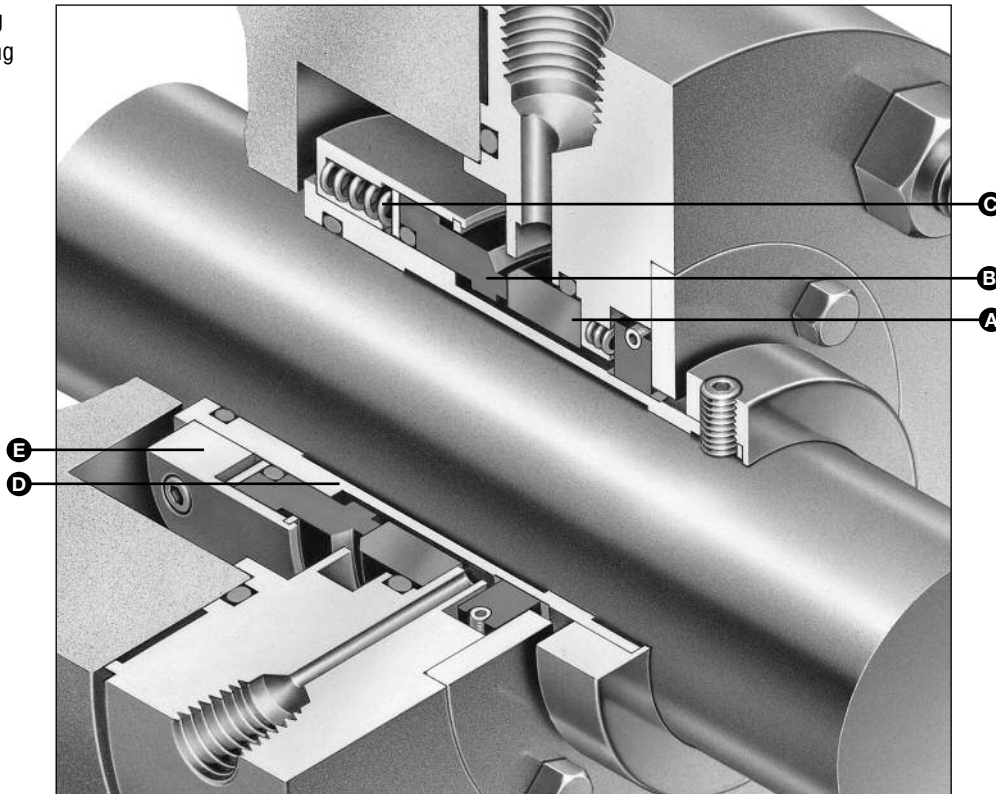

Product Description

The Type 48 is a dependable, engineered mechanical seal developed specifically for single seal installations to attain maximum achievable controllable technology (MACT) compliance in light hydro-carbons and other volatile organic compounds (VOCs). Type 48 single seals control emissions to less than 500 ppm. Available in cartridge or optional shaft-mounted seal arrangement.

- Industrial applications involved in the processing of VOCs and similar hazardous materials
- Lubrication liquids, aqueous solutions, chemicals, light hydrocarbons, and water services

Performance Capabilities

- Temperature: -40°F to 500°F/-40°C to 260°C
- Pressure: 1000 psi(g)/69 bar(g)
- Speed: u++p to 5,000 fpm/25 m/s

Consult John Crane for higher speed and pressure applications.

Design Features

Low emission single seal — Designed to satisfy U.S.A. federal, state, and local regulatory requirements. Type 48 assures emission control with a single seal arrangement in VOC services. Years of low emission sealing are provided. Available with fixed, floating, and segmented type throttle bushings that can be suited to fit the application needs.

Type 48 sealing package — Application-specific with the proper selection of primary ring, mating ring materials, and flush arrangement. Each seal has the built-in capability to offset the combined effects of pressure distortion, thermal distortion, and heat generation on leakage and wear. Specific seal head application is based on seal size, shaft speed, and other variables. Type 48 Seals also can be provided in an unpressurized/pressurized dual seal.

Computer optimized seal faces — Minimizes thermal and pressure caused distortion. For optimal performance, face materials are specified antimony filled carbon graphite versus silicon carbide as standard. For higher duty applications, the 48HP uses a special hydropadded face geometry. O-ring drag is reduced by tighter tolerances and smoother sliding surfaces.

Flush maximizes cooling — Available with an extended flush with single point injection and a large percentage of the mating ring exposed to the process fluid for cooler running. For higher heat loads, a distributed flush with improved heat transfer characteristics is recommended.

TYPE 48LP/48HP

LOW EMISSION ELASTOMER O-RING SEALS

Type 48LP (Low Pressure) Typical Arrangement

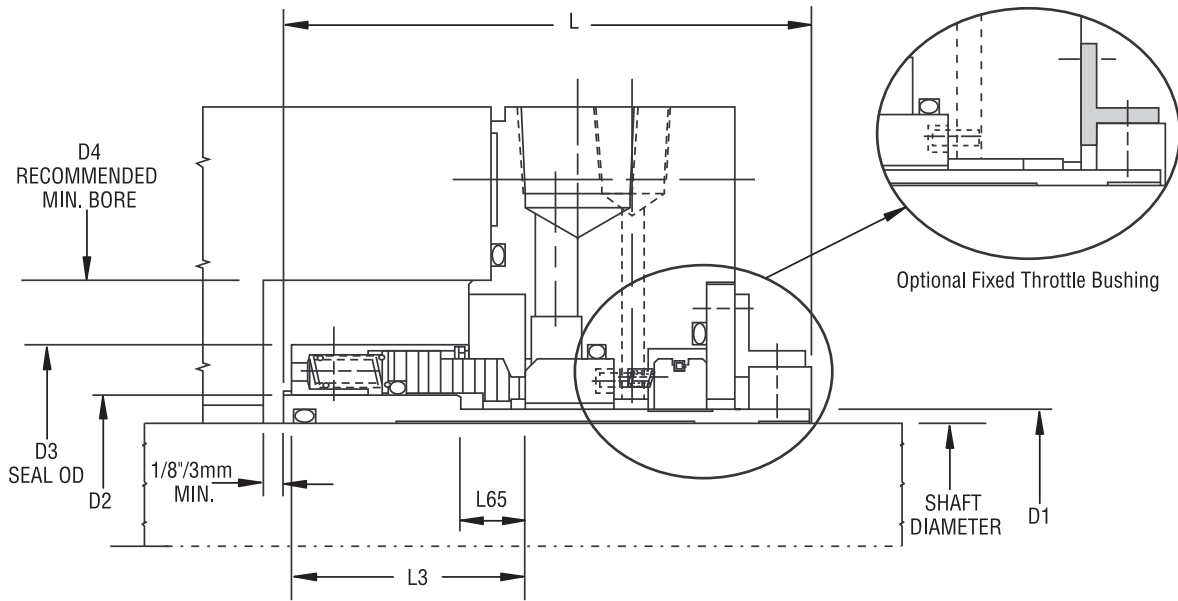

Type 48HP (High Pressure) Typical Arrangement

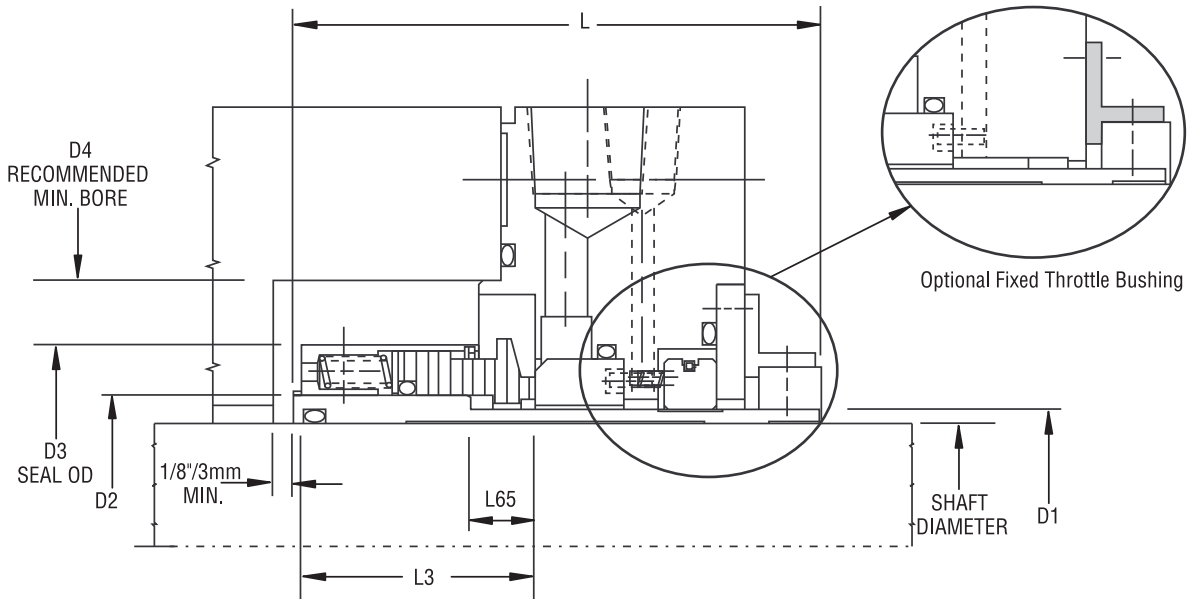

TYPE 48LP/48HP

LOW EMISSION ELASTOMER O-RING SEALS

Type 48 Dimensional Data (inches)

Shaft Dia. (inches)	D1	D2	D3	D4	L3	L65	L
1.000	1.250	1.500	2.125	2.500	1.437	0.343	3.687
1.125	1.375	1.625	2.375	2.750	1.750	0.437	4.000
1.250	1.500	1.750	2.500	2.875	1.750	0.437	4.000
1.375	1.625	1.875	2.625	3.000	1.750	0.437	4.062
1.500	1.750	2.000	2.750	3.125	1.750	0.437	4.062
1.625	1.875	2.125	3.000	3.375	2.062	0.500	4.375
1.750	2.000	2.250	3.125	3.500	2.062	0.500	4.375
1.875	2.125	2.375	3.250	3.625	2.062	0.500	4.437
2.000	2.250	2.500	3.375	3.750	2.062	0.500	4.437
2.125	2.375	2.625	3.500	3.875	2.062	0.500	4.437
2.250	2.500	2.750	3.625	4.000	2.062	0.500	4.437
2.375	2.625	2.875	3.750	4.125	2.062	0.500	4.500
2.500	2.750	3.000	3.812	4.187	2.062	0.500	4.500
2.625	2.875	3.125	3.937	4.312	2.062	0.562	4.500
2.750	3.000	3.250	4.125	4.500	2.062	0.562	4.500
2.875	3.125	3.375	4.250	4.625	2.062	0.562	4.656
3.000	3.250	3.500	4.375	4.750	2.062	0.562	4.656
3.125	3.375	3.625	4.500	4.875	2.062	0.562	4.656
3.250	3.500	3.750	4.625	5.000	2.062	0.562	4.656
3.375	3.625	3.875	4.750	5.125	2.062	0.562	4.656
3.500	3.750	4.000	4.875	5.250	2.062	0.562	4.656
3.625	3.875	4.125	5.125	5.500	2.062	0.562	4.656
3.750	4.000	4.250	5.250	5.625	2.062	0.562	4.656
3.875	4.125	4.375	5.375	5.750	2.062	0.562	4.656
4.000	4.250	4.500	5.500	5.875	2.062	0.562	4.656

Can be fitted to metric shaft sizes in cartridge form. Contact John Crane.

Primary Ring Geometry

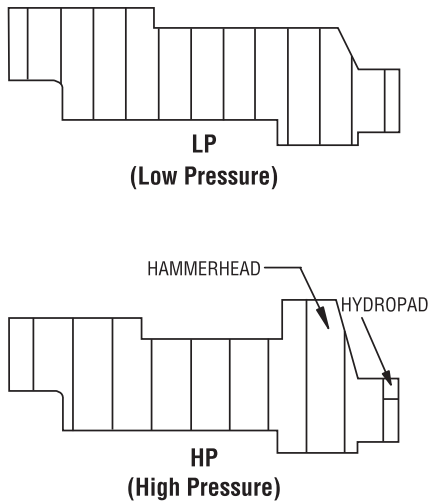

Flush Arrangements

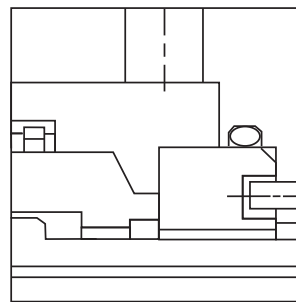

This is a single point injection, providing maximum exposure of the mating ring surface.

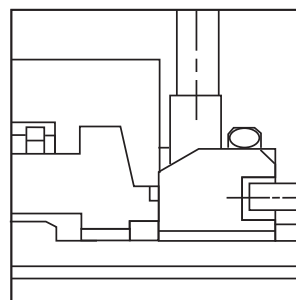

This has a mating ring annulus around the outside diameter (OD) and is used in conjunction with a chamfered mating ring to direct flow at the sealing faces.

DISTRIBUTED FLUSH

Pressure Ratings

Type 48LP

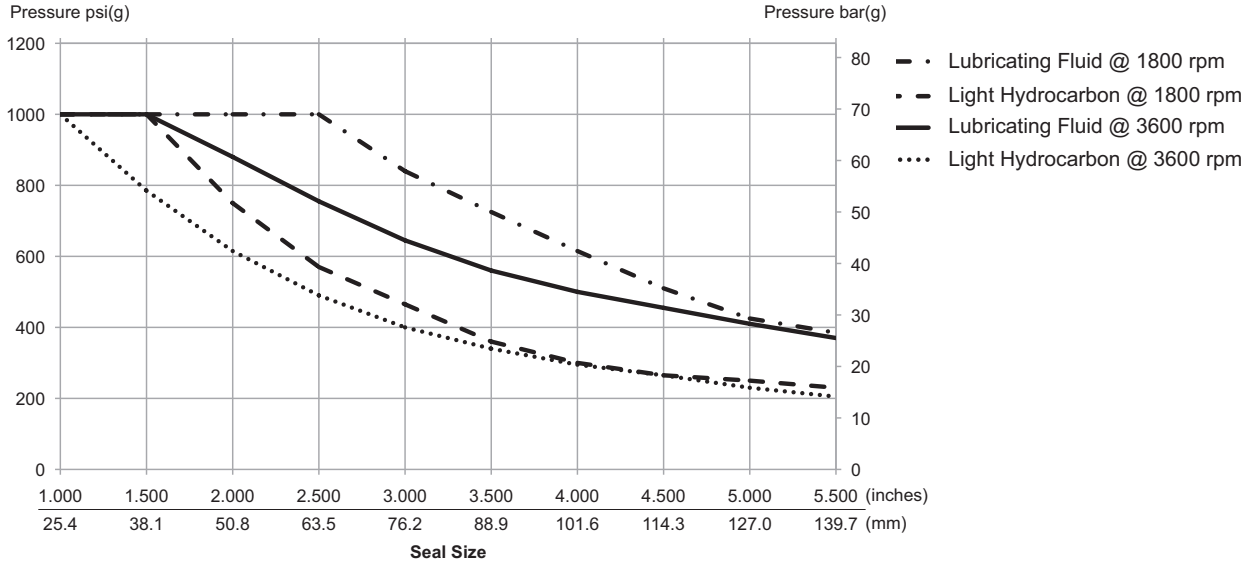

Type 48HP

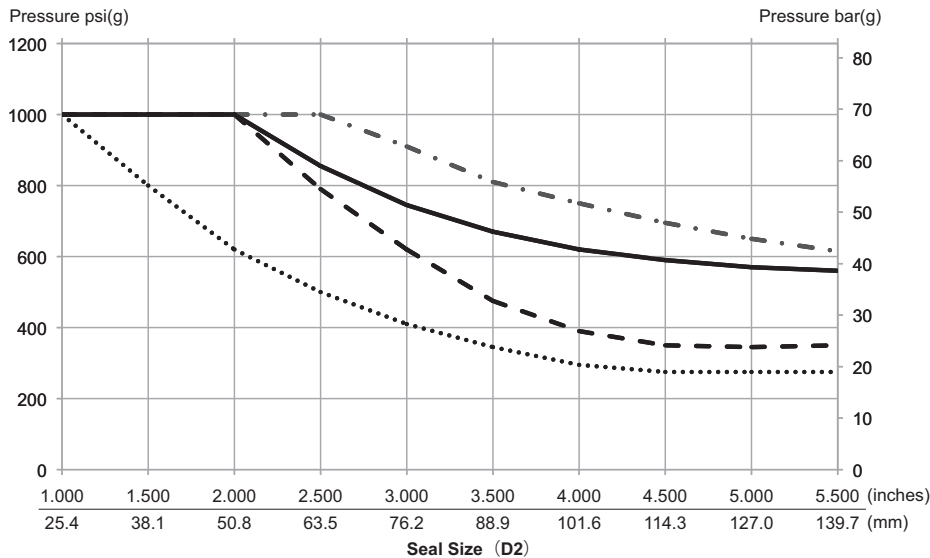

Pressure Limit Modifiers

	Selection Considerations	Pressure Factor
Sealed Fluid Temperature	Below 175°F/80°C	x 1.00
	Above 175°F to 250°F/80°C to 120°C	x 0.90
	Above 250°F to 350°F/120°C to 180°C	x 0.80
	Above 350°F to 500°F/180°C to 260°C	x 0.65
Sealed Fluid Lubricity*	Aqueous Solutions	x 0.75

*For aqueous solutions, apply 0.75 multiplier factor to the lubricating fluid curve.

NOTES:

- The above temperature derating factors apply to seals with carbon primary rings only not hard face vs. hard face combinations.
- The temperatures noted are product temperatures for single seals or the expected average temperature of the product and buffer/barrier fluid for dual seals.

Example for Determining Pressure Rating Limits:

Seal: 3"/75mm diameter Type 48LP

Product: Lube oil

Temperature: 180°F/82°C

Speed: 3600 rpm

Using Chart 1 Type 48LP, the pressure limit is 645 psi(g)/44.5 bar(g). From the table of modifiers apply the appropriate value, in this case 0.9. For this service condition, the maximum operating pressure is:

$$645 \text{ psi(g)} \times 0.9 = 580.5 \text{ psi(g)/40 bar(g)}$$

Materials of Construction

SEAL COMPONENTS	MATERIALS	
Description	Standard	Options
Face/Primary Ring	Premium Carbon Graphite	Resin Carbon Nickel Binder Tungsten Carbide Reaction Bonded Silicon Carbide Alpha Sintered Silicon Carbide
Seat/Mating Ring	Alpha Sintered Silicon Carbide	Nickel Binder Tungsten Carbide Reaction Bonded Silicon Carbide
Drive Collar Gland Plate Sleeve Retainer Disc Set Screws Snap Ring	316 Stainless Steel	—
Spring	Alloy C-276 (UNS N10276)	—
O-Ring	Fluoroelastomer	Perfluoroelastomer Nitrile Low Temperature Nitrile



TYPE 48LP/48HP

LOW EMISSION ELASTOMER O-RING SEALS

Technical Specification

Hydrostatic Pressure Limits

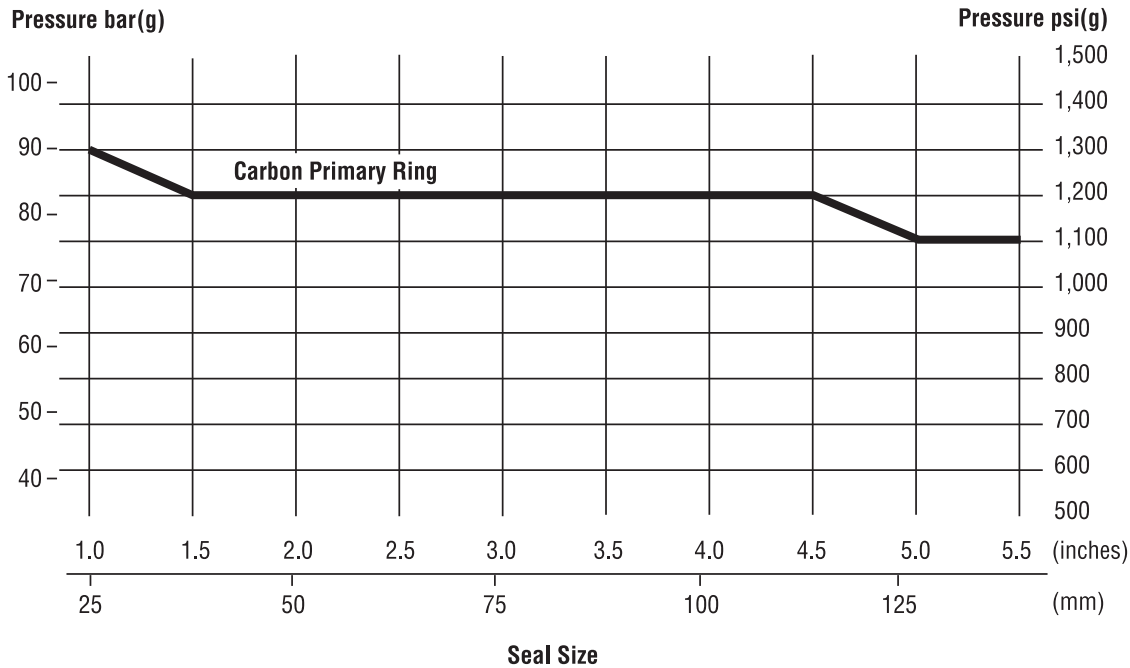

NOTE: Maximum static sealing pressure shall be greater of the two values:

1. Hydrostatic pressure limit ÷ 1.5
2. Maximum dynamic sealing pressure

Criteria for Installation

Shaft/Sleeve	Limits
Surface Finish	0.40µmRa/16"Ra
Ovality/Out of Roundness (Shaft)	0.002"/0.051mm
End Play/Axial Float Allowance	±0.005"/0.13mm

john crane

TYPE 48LP/48HP

LOW EMISSION ELASTOMER O-RING SEALS

Technical Specification

TYPE 48LP/48HP

LOW EMISSION ELASTOMER O-RING SEALS

Technical Specification



North America
 United States of America
 Tel: 1-847-967-2400
 Fax: 1-847-967-3915

Europe
 United Kingdom
 Tel: 44-1753-224000
 Fax: 44-1753-224224

Latin America
 Brazil
 Tel: 55-11-3371-2500
 Fax: 55-11-3371-2599

Middle East & Africa
 United Arab Emirates
 Tel: 971-481-27800
 Fax: 971-488-62830

Asia Pacific
 Singapore
 Tel: 65-6518-1800
 Fax: 65-6518-1803

If the products featured will be used in a potentially dangerous and/or hazardous process, your John Crane representative should be consulted prior to their selection and use. In the interest of continuous development, John Crane Companies reserve the right to alter designs and specifications without prior notice. It is dangerous to smoke while handling products made from PTFE. Old and new PTFE products must not be incinerated. ISO 9001 and ISO14001 Certified, details available on request.