

TYPE 2800E

EXTERNALLY MOUNTED, GAS LUBRICATED, NON-CONTACTING, DOUBLE CARTRIDGE SEAL

Technical Specification

- A – Seat/Mating Ring
- B – Face/Primary Ring (inboard)
- C – Spring
- D – Face/Primary Ring (outboard)
- E – O-Ring
- F – Drive Collar
- G – Setting Ring
- H – Sleeve

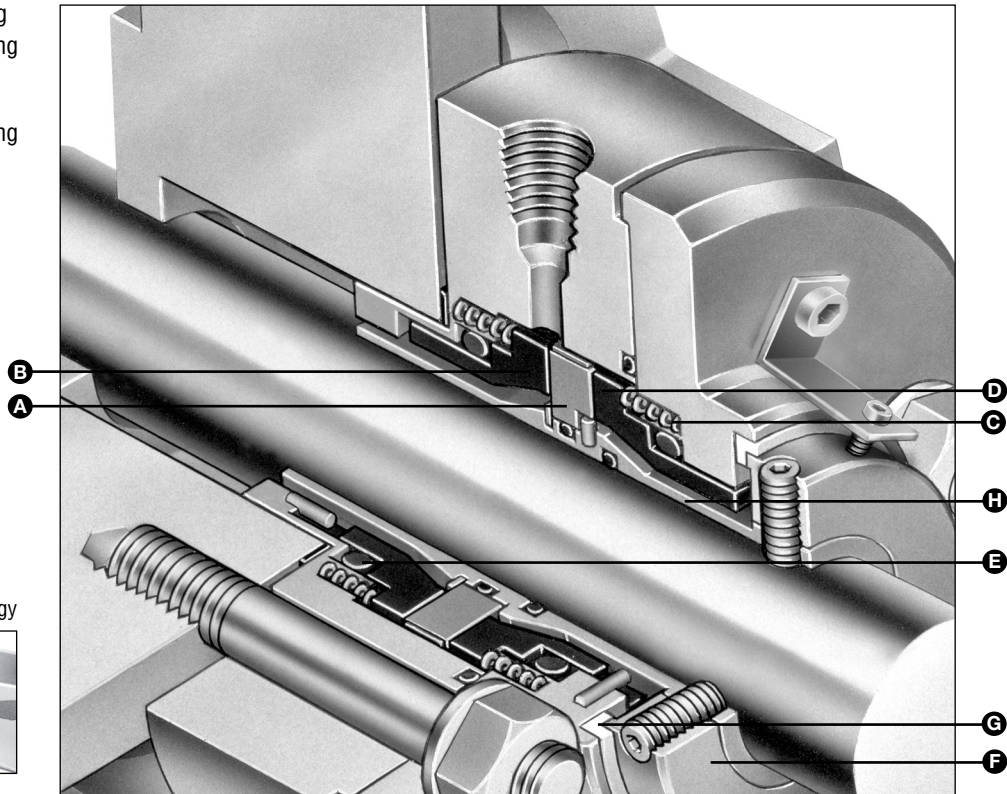

Spiral Groove Technology



Product Description

Type 2800E is a state-of-the-art gas lubricated, non-contacting double seal cartridge for use in ANSI or DIN standard bore pumps or limited space applications. The 2800E provides zero emissions operation, extended seal life, reduced power consumption, and elimination of wet seal lubrication system. It uses an available pressurized inert gas source for positively sealing hazardous process fluids with zero emissions to atmosphere. Non-contacting, dry-running technology provides high performance sealing of heat sensitive or high purity fluids.

- For maximum achievable control technology (MACT) compliance in new or existing standard bore pumps
- For high reliability sealing of volatile fluids in chemical and petrochemical processes
- Double seal alternative for positive sealing of high purity fluids without the potential for product contamination

Performance Capabilities

- Temperature: -40°F to 500°F/-40°C to 260°C
 - Pressure: up to 232 psi(g)/16 bar(g)
 - Speed: up to 5000 fpm/25 m/s
- Higher operating conditions are achievable. Consult John Crane.

Design Features

- 0.0 fugitive emissions
- Compact design
- Dual balance inboard seal design
- Spiral groove technology
- Non-contacting design
- Simplified support system

TYPE 2800E

**EXTERNALLY MOUNTED, GAS LUBRICATED,
NON-CONTACTING, DOUBLE CARTRIDGE SEAL**

Technical Specification

Type 2800E Typical Arrangement

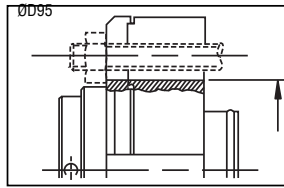
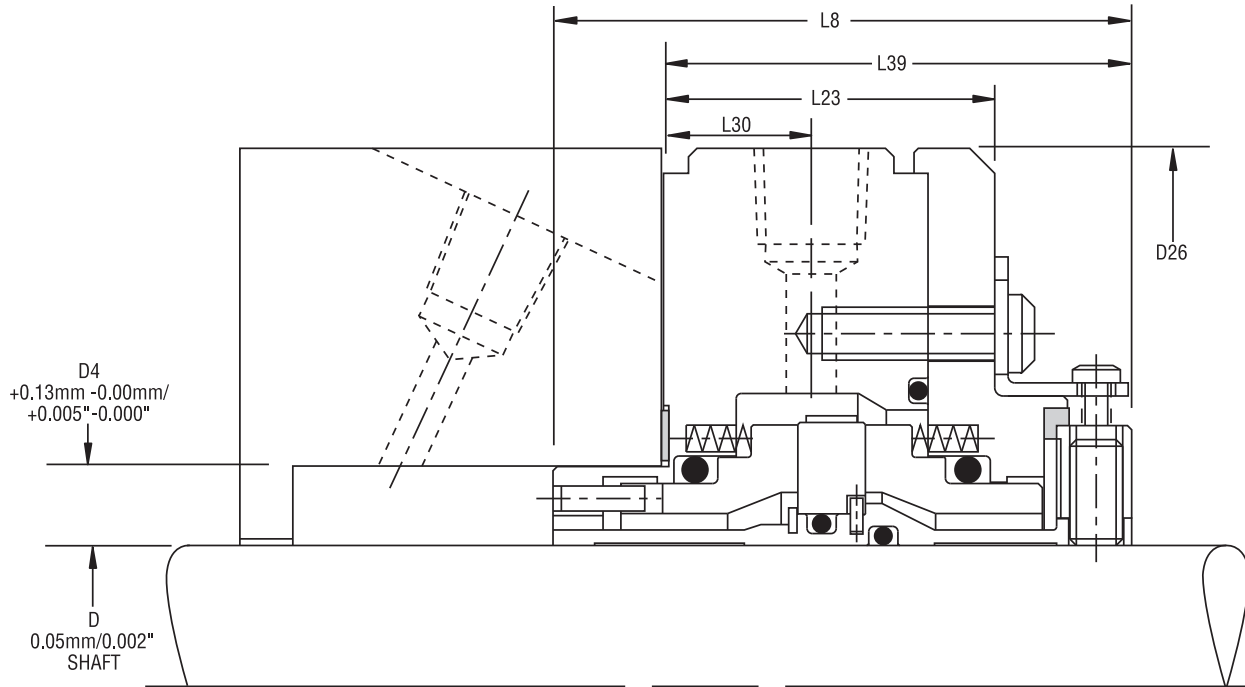

$D95$ is the minimum possible dimension between diametrically opposed fixing bolts. $\text{Ø}D28$ is the bolt slot width.

Type 2800E Dimensional Data (mm)

Seal Size (mm)	Seal Size Code	D	D4	D26	D28	D95	L8	L23	L30	L39
25	0250	25	41	114	12	64.7	67.8	37.5	15.5	54.5
28	0280	28	44	117	12	67.7	67.8	37.5	15.5	54.5
30	0300	30	46	119	12	69.7	67.8	37.5	15.5	54.5
33	0330	33	49	122	14	72.7	67.8	37.5	15.5	54.5
35	0350	35	51	124	14	74.7	67.8	37.5	15.5	54.5
38	0380	38	58	135	14	79.7	69.4	39.8	17.7	56.5
40	0400	40	60	137	14	81.7	69.4	39.8	17.7	56.5
43	0430	43	63	140	14	84.7	69.4	39.8	17.7	56.5
45	0450	45	65	142	14	86.7	69.4	39.8	17.7	56.5
50	0500	50	70	147	18	91.7	69.4	41.8	17.7	56.5
53	0530	53	73	150	18	94.7	69.4	41.8	17.7	56.5
55	0550	55	75	152	18	96.7	69.4	41.8	17.7	56.5
60	0600	60	85	157	18	101.7	69.4	41.8	17.7	56.5
65	0650	65	90	180	18	106.7	71.4	43.8	19.7	58.5
80	0800	80	109	195	18	121.7	71.4	43.8	19.7	58.5
100	1000	100	129	215	22	141.7	71.4	43.8	19.7	58.5

TYPE 2800E

**EXTERNALLY MOUNTED, GAS LUBRICATED,
NON-CONTACTING, DOUBLE CARTRIDGE SEAL**

Technical Specification

Type 2800E Dimensional Data (inches)

Seal Size/D1 (inches)	Seal Size/D Code	D4	D26	D28	D95	L8	L23	L30	L39
0.875	0222	1.500	3.750	0.437	2.295	2.574	1.398	0.531	2.028
1.000	0254	1.625	3.750	0.437	2.421	2.574	1.398	0.531	2.028
1.125	0285	1.750	4.250	0.437	2.469	2.574	1.398	0.531	2.028
1.250	0317	2.000	4.250	0.437	2.669	2.574	1.398	0.531	2.028
1.375*	0349	2.125	4.250	0.437	2.795	2.574	1.398	0.531	2.028
1.375**	0349	2.000	4.250	0.437	2.795	2.574	1.398	0.531	2.028
1.500	0381	2.250	4.875	0.562	3.142	2.732	1.567	0.697	2.224
1.625	0412	2.375	4.500	0.437	3.268	2.732	1.567	0.697	2.224
1.750	0444	2.500	5.500	0.562	3.390	2.732	1.567	0.697	2.224
1.875	0476	2.625	5.500	0.562	3.335	2.732	1.567	0.697	2.224
2.000	0508	2.750	4.750	0.562	3.461	2.732	1.567	0.697	2.224
2.125	0539	2.875	6.000	0.687	3.768	2.732	1.567	0.697	2.224
2.250	0571	3.125	6.500	0.687	3.890	2.732	1.567	0.697	2.224
2.375	0603	3.250	6.250	0.687	4.016	2.732	1.567	0.697	2.224
2.500	0635	3.375	6.500	0.687	4.142	2.812	1.724	0.776	2.303
2.625	0666	3.625	6.500	0.687	4.268	2.812	1.724	0.776	2.303
2.750	0698	3.750	7.000	0.687	4.370	2.812	1.724	0.776	2.303
3.000	0762	4.000	7.000	0.687	4.642	2.812	1.724	0.776	2.303
3.500	0889	4.500	7.250	0.812	5.142	2.812	1.724	0.776	2.303
4.000	1016	5.000	7.250	0.812	5.642	2.812	1.724	0.776	2.303

*Durco **Goulds

Pressure Limits

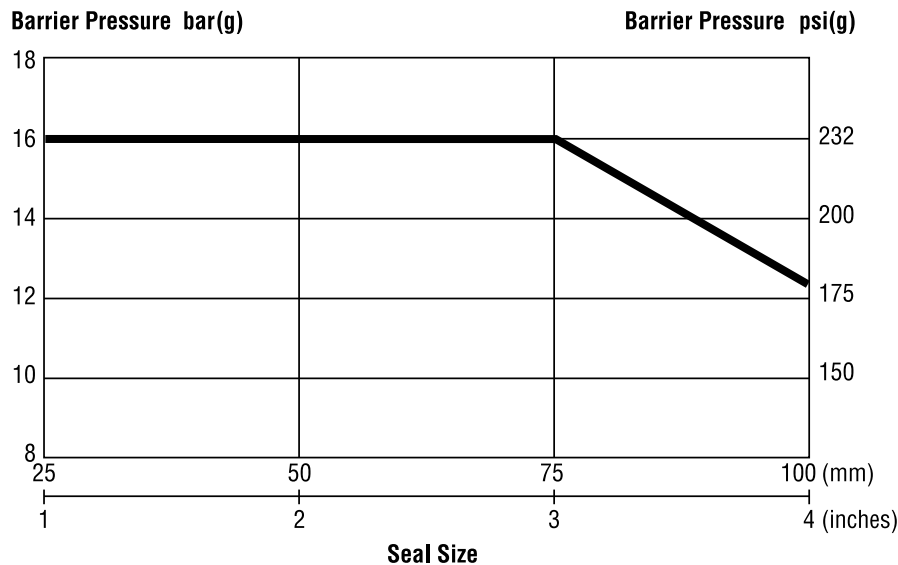

The basic pressure rating is based on a standard seal installed according to the criteria given in this data sheet at a minimum speed of 1450rpm, and according to generally accepted industrial practices.

Contact John Crane for process services outside this range and with more detailed application information in order to obtain the actual dynamic pressure rating.

TYPE 2800E

**EXTERNALLY MOUNTED, GAS LUBRICATED,
NON-CONTACTING, DOUBLE CARTRIDGE SEAL**

Technical Specification

Criteria for Installation

SHAFT/SLEEVE	LIMITS
Surface Finish	1.6µmRa/63Ra or better
Ovality/Out of Roundness (Shaft)	0.05mm/0.002"
End Play/Axial Float Allowance	±0.08mm/0.003"
Runout/Out of Squareness	0.051mm/0.002"
Shaft Squareness to Housing	0.08mm/0.003"

Barrier Gas Consumption

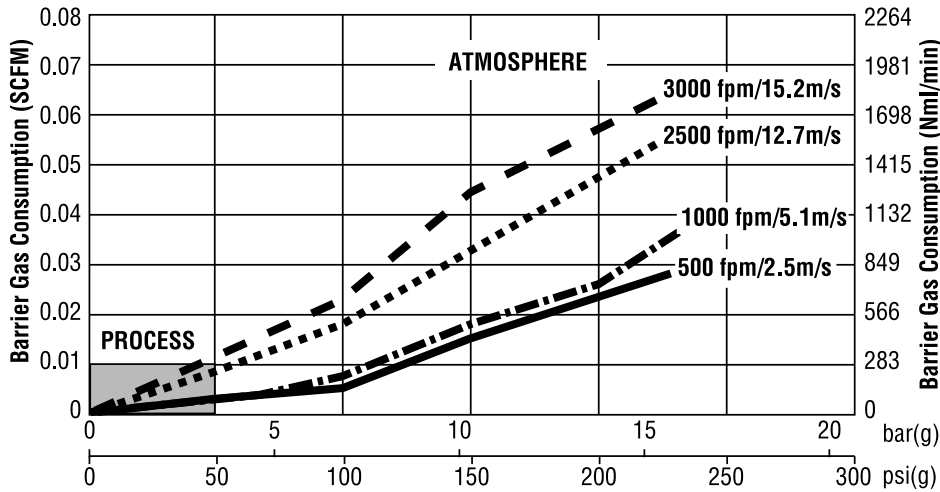

NOTES:

1. Data based on each seal face.
2. Consumption based on ambient temperature and atmospheric pressure flow indicated by flowmeter at gas inlet is compressed gas and therefore considerably less.

$$\text{fpm} = \text{Seal Size (inches) Dia.} + 0.50" \times \text{rpm} \times 0.2618$$

*Curves are to be used as a guide only. Actual consumption rates may vary. Consult John Crane if specific application gas consumption data is required.

TYPE 2800E

EXTERNALLY MOUNTED, GAS LUBRICATED, NON-CONTACTING, DOUBLE CARTRIDGE SEAL

Technical Specification

Barrier Gas Supply Systems

Available from John Crane in both standard tamper proof enclosure and panel mounted designs.

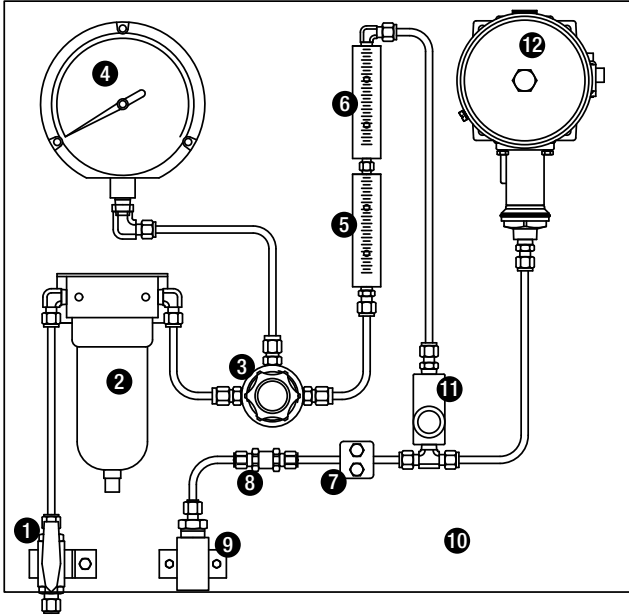

Barrier Supply ↑
Seal Chamber ↓

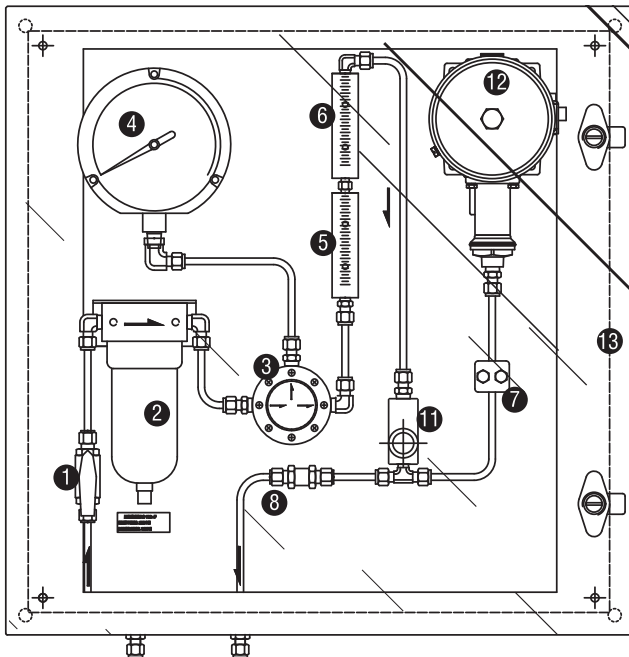

Standard Components

- 1 Isolating Ball Valve
- 2 Coalescing Filter
- 3 Pressure Regulator
- 4 Pressure Gauge
- 5 Flow Meter (Low Range)
- 6 Flow Meter (High Range)
- 7 Tubing Clamp
- 8 Check Valve
- 9 Coupling (To Seal Piping)
- 10 Back Panel

Options

- 11 Flow Switch
- 12 Pressure Switch
- 13 Enclosure
 - Isolast™ and Kalrez® for the Check Valve Seat Material
 - Stand
 - Enclosures are also available in a NEMA 4X Enclosure (as shown)
 - Gas Amplifier/Booster Systems
 - Pressure Tracking Regulators

Further application information is available from John Crane.

GAS FLOW SCHEMATIC

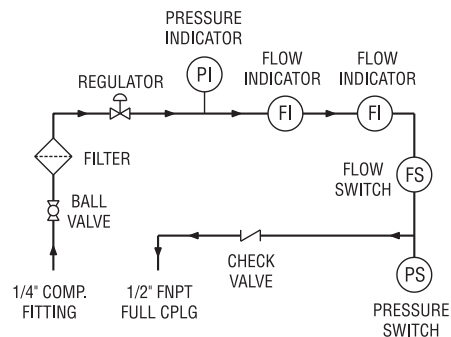

TYPE 2800E

**EXTERNALLY MOUNTED, GAS LUBRICATED,
NON-CONTACTING, DOUBLE CARTRIDGE SEAL**

Technical Specification

Materials of Construction

SEAL COMPONENTS	MATERIALS	
	Description	Standard
Face/Primary Ring	Carbon	—
Seat/Mating Ring	Tungsten Carbide	Silicon Carbide
Cap Head Screws Anti-Rotation Pins Snap Ring Sleeve Gland Plate Spring Set Screws Drive Collar Drive Pins	316 Stainless Steel	Alloy 20GB3 SS (UNS N8020) Alloy C-276 (UNS N10276) Titanium
O-Rings	Fluoroelastomer	Perfluoroelastomer EPR
Setting Ring (Spacer)	Pure PTFE	—
Gasket	PTFE Glass Filled	—

john crane

TYPE 2800E

**EXTERNALLY MOUNTED, GAS LUBRICATED,
NON-CONTACTING, DOUBLE CARTRIDGE SEAL**

Technical Specification

TYPE 2800E

**EXTERNALLY MOUNTED, GAS LUBRICATED,
NON-CONTACTING, DOUBLE CARTRIDGE SEAL**

Technical Specification

Isolast is a registered trademark of Trelleborg.

Kalrez is a registered trademark of DuPont.



North America	Europe	Latin America	Middle East & Africa	Asia Pacific
United States of America	United Kingdom	Brazil	United Arab Emirates	Singapore
Tel: 1-847-967-2400	Tel: 44-1753-224000	Tel: 55-11-3371-2500	Tel: 971-481-27800	Tel: 65-6518-1800
Fax: 1-847-967-3915	Fax: 44-1753-224224	Fax: 55-11-3371-2599	Fax: 971-488-62830	Fax: 65-6518-1803

If the products featured will be used in a potentially dangerous and/or hazardous process, your John Crane representative should be consulted prior to their selection and use. In the interest of continuous development, John Crane Companies reserve the right to alter designs and specifications without prior notice. It is dangerous to smoke while handling products made from PTFE. Old and new PTFE products must not be incinerated. ISO 9001 and ISO14001 Certified, details available on request.