

- A – Housing
- B – Retainer
- C – Clamp plate
- D – Garter spring
- E – Bushing segment
- F – Sleeve

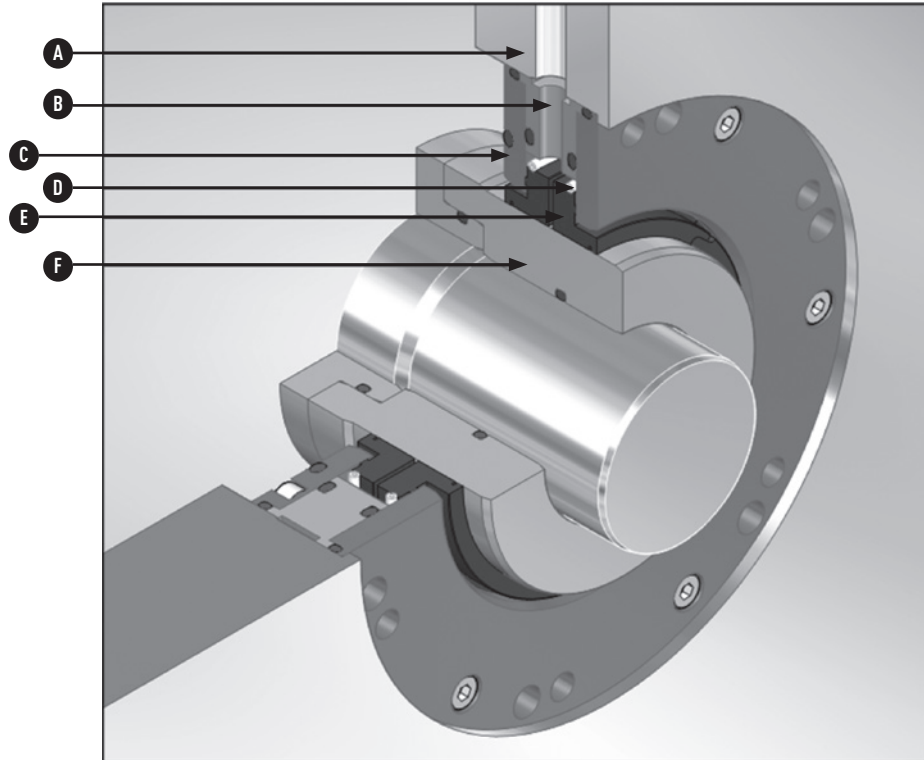

Product Description

Type 93LR is a non-contacting carbon bushing designed to prevent the dry gas seal cartridge from ingress of bearing oil.

- Separation gas (normally nitrogen or air) is injected between the two segmented bushings effectively creating a pressure barrier between the bearing and dry gas seal cavity
- Segments are balanced and designed to lift off when separation gas is applied
- Advanced materials and design ensure minimal wear

Design Features

- Low separation gas consumption in both pressure and flow control methodologies
- Minimised effects of temperature on separation gas consumption
- Bi-directional design
- Specially designed segmented joints to improve consumption efficiency
- Suitable for running with nitrogen separation gas, irrespective of dew point
- Suitable for slow roll conditions
- Close fit to shaft/sleeve when supply pressure is off

Performance Capabilities

- Size range: 40 to 300 mm/1.57 to 11.81 in
(with sleeve to fit all metric or imperial shaft sizes)
 - Temperature: -50°C to 200°C/-58°F to 392°F
 - Speed: Up to 130 m/s/430 fps
 - Pressure: Design: 0.1 to 5 bar/1.5 to 72.5 psi
Separation gas operating differential pressure: 0.1 to 0.5 bar/1.5 to 7.3 psi
Maximum sealing integrity: 35 bar/508 psi
 - Gases: Nitrogen, air
 - Vibration levels: Compliance with API 617 and ISO7919-3
- For alternative conditions, consult John Crane Engineering.

Typical Arrangement with a Tandem Seal

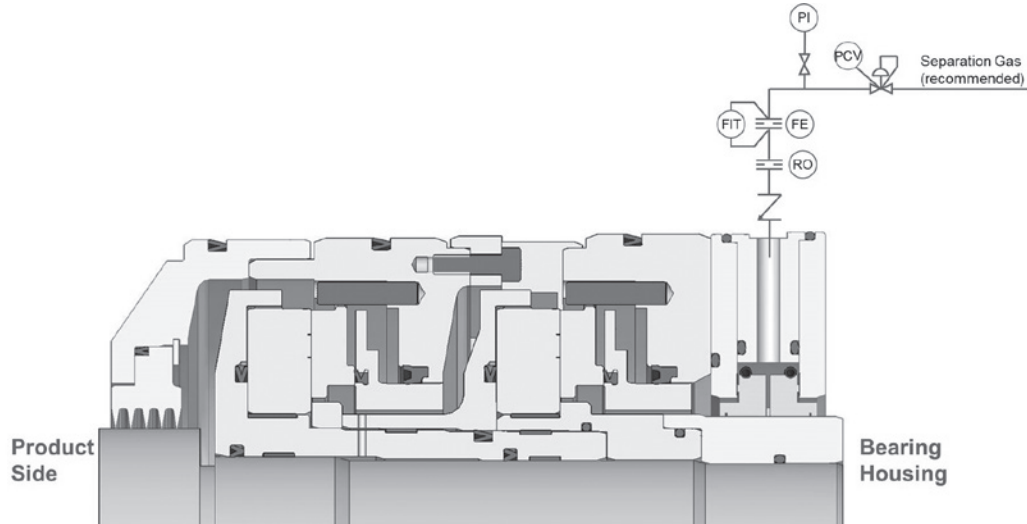

Materials of Construction

Seal Component Description	Standard Materials
Bushing segments	Carbon
Axial spring	Stainless steel
Radial springs	Stainless steel
Housing assembly Clamp plate assembly	410 stainless steel
Secondary sealing elements	Fluoroelastomer

Alternative materials are available, consult John Crane Engineering.

Performance Recommendations

Separation gas specification

- Filtration: 10 microns and dry
- Proper consideration must be given as to the possibility of explosive mixtures.

Operating Environment

- Bearing housing should be well drained.
- Bearing housing should not be pressurized.
- Consideration should be given to the secondary vent piping as not to cause an excessive back pressure.
- Oil exiting the bearing cavity directed at the separation seal should be noted at design.

Alternative Options

Type 93LR is normally supplied as a double separation seal as depicted in this data sheet.

Please consult John Crane Engineering.