

TYPES 2609HTC, 3609HTC, 2609HTL AND 3609HTL

METAL BELLOWS SEAL

Type 2609HTC/3609HTC

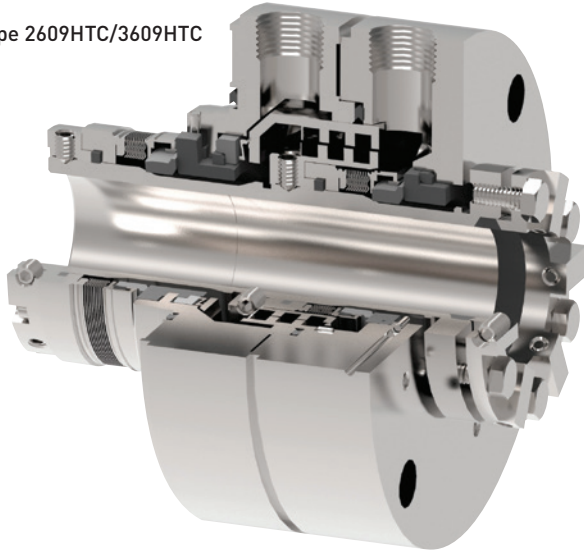

Type 2609HTL/3609HTL

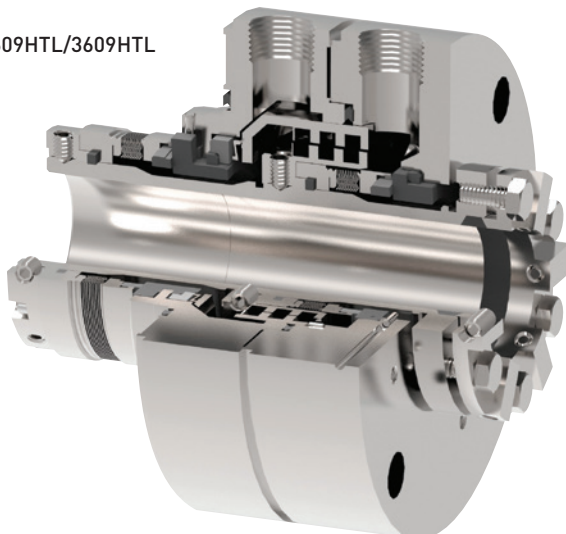

DESIGN BENEFITS

- Proven performance
API 682 qualified
- HTC and HTL technology for
superior face stability and
improved MTBR
- Withstands full reverse
pressurization
- Incorporates dual scroll pumping
device for maximum flow

PRODUCT DESCRIPTION

- High Temperature edge-welded metal bellows dual pressurized (3609HTC and 3609HTL) or unpressurized (2609HTC and 2609HTL) rotating API 682 Type C, Arrangement 2 and 3 Cartridge seals provide a reliable means of sealing fluids in harsh high temperature corrosive environments. These dependable cartridge seals utilize two impressive design innovations by incorporating **High-Temperature Corrosion Resistant Sealing (HTC)** and unique **High-Temperature Live-loaded (HTL) Mating Ring** technology in the Types 2609HTC & 3609HTC or a standard high-temperature seal head assembly combined with HTL Mating Ring technology in the Types 2609HTL & 3609HTL. Both HTC and HTL technologies vastly enhance seal face stability and can extend your MTBR in many services.

TYPES 2609HTC, 3609HTC, 2609HTL AND 3609HTL

METAL BELLOWS SEAL

HTC Technology and Excellent Corrosion Resistance

The HTC seals provide an effective solution in sealing corrosive fluids at elevated temperatures by using an all-Inconel® design and unique face seal technology that provides exceptional stability across a wide range of pressure/temperature conditions. The HTC has proven to be a superior design for high temperature corrosive applications up to 800°F/425°C and is ideally suited for applications that contain organic acids (naphthenic acids) or sulfur compounds that attack most other alloys in aggressive, hot, sour crude environments.

HTL Technology

With HTL mating ring design, seal face stability is achieved by eliminating any thermal and mechanical forces that can contribute to seal face distortion. The sealing interface, especially when combined with HTC technology, remains exceptionally stable despite thermal changes and adapts to the wide range of temperature excursions inherent in high-temperature applications.

Full Reverse Pressure Containment Capability

This inherently safe design provides process fluid containment safety against system upsets and/or loss of barrier fluid pressure on dual seal systems.

Dual Scroll Pumping Device

Optimized dual scroll pumping device delivers significantly more flow over single scroll and other pumping devices, especially in high temperature applications with high heat loads or low shaft speeds. This dual scroll pumping device with tapered-bore-inner-gland improves seal performance by removing more heat, extending the life of barrier fluids and reducing the bulk temperature, thus reducing coking of hot hydrocarbons. Additionally, it can provide effective cooling in large shaft, slower speed equipment.

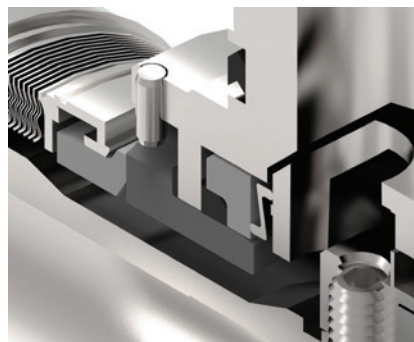

Performance Capabilities

Temperature	Pressure	Speed
-100° to 800°F/-75° to 425°C	Vacuum to 300 psig/20 barg <i>(Consult basic pressure rating curves.)</i>	Up to 5,000 fpm/25 ms ⁻¹

Together, we will work with you to keep your mission-critical operations up and running with support and guidance from our experienced team.

Consult John Crane Engineering for your specific seal selection.



North America

United States of America
Tel: 1-847-967-2400
Fax: 1-847-967-3915

Europe

United Kingdom
Tel: 44-1753-224000
Fax: 44-1753-224224

Latin America

Brazil
Tel: 55-11-3371-2500
Fax: 55-11-3371-2599

Middle East & Africa

United Arab Emirates
Tel: 971-481-27800
Fax: 971-488-62830

Asia Pacific

Singapore
Tel: 65-6518-1800
Fax: 65-6518-1803

If the products featured will be used in a potentially dangerous and/or hazardous process, your John Crane representative should be consulted prior to their selection and use. In the interest of continuous development, John Crane Companies reserve the right to alter designs and specifications without prior notice. It is dangerous to smoke while handling products made from PTFE. Old and new PTFE products must not be incinerated. ISO 9001 and ISO 14001 Certified, details available on request.