

## DUAL CARTRIDGE SEAL

Installation, Operation & Maintenance Instructions

### Foreword

These instructions are provided to familiarize the user with the seal and its designated use. The instructions must be read and applied whenever work is done on the seal, and must be kept available for future reference.

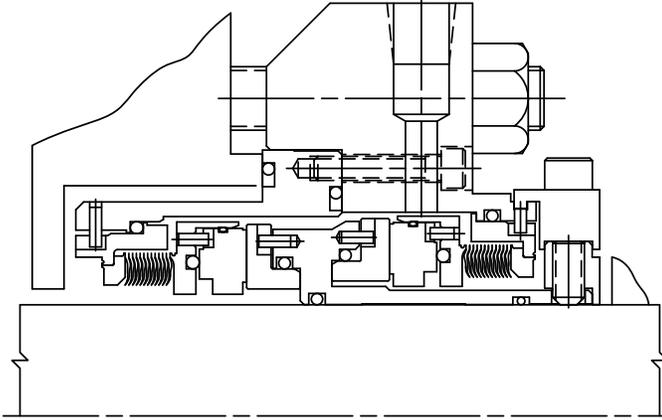

**ATTENTION**

These instructions are for the installation and operation of a seal as used in rotating equipment, and will help to avoid danger and increase reliability. The information required may change with other types of equipment or installation arrangements. These instructions must be read in conjunction with the instruction manuals for both the pump and any ancillary equipment.

If the seal is to be used for an application other than that originally intended or outside the recommended performance limits, John Crane must be contacted before its installation and use.

Any warranty may be affected by improper handling, installation or use of this seal. Contact John Crane for information as to exclusive product warranty and limitations of liability.

If questions or problems arise, contact your local John Crane representative or the original equipment manufacturer, as appropriate.

**ATTENTION**

John Crane mechanical seals are precision products and must be handled appropriately. Take particular care to avoid damage to flexible sealing rings. Do not excessively compress the seal before or during installation.

### Safety Instructions

- The following designations are used in the installation instructions to highlight instructions of particular importance.

**NOTE:** Refers to special information on how to install or operate the seal most efficiently.

**ATTENTION** Refers to special information or instructions directed towards the prevention of damage to the seal or its surroundings.



Refers to mandatory instructions designed to prevent personal injury or extensive damage to the seal or its surroundings.

- Installation, removal and maintenance of the seal must be carried out only by qualified personnel who have read and understood these installation instructions.
- The seal is designed exclusively for sealing rotating shafts. The manufacturer cannot be held liable for use of the seal for purposes other than this.
- The seal must only be used in technically perfect condition, and must be operated within the recommended performance limits in accordance with its designated use set out in these installation instructions.
- If the pumped fluid is hazardous or toxic, appropriate precautions must be taken to ensure that any seal leakage is adequately contained. Further information on sealing hazardous or toxic fluids should be obtained from John Crane prior to seal installation.
- PTFE and fluorocarbon components should never be burned or incinerated as the fumes are highly toxic. If fluorocarbons are accidentally heated above 400°C/750°F, they can decompose. Protective gloves should be worn as hydrofluoric acid may be present.

### Before Starting the Equipment (continued)

**WARNING:** Seal installation should be handled only by qualified personnel. If questions arise, contact the local John Crane representative. Improper use and/or installation of this product could result in injury to the person and/or harmful emissions to the environment, and may affect any warranty on the product. Please contact the company for information as to exclusive product warranty and limitations of liability.

### General Instructions

- Study the engineering layout drawing to confirm the proper seal arrangement for the pump being used.
- To assure satisfactory operation, handle seal with care. Take particular caution to see that the lapped sealing faces are not scratched or damaged.

Part Name		
1 Inner Gland Plate Assembly	7 Inner Bellows	13 Adapter
2 Outer Gland Plate Assembly	8 Outer Bellows	14 Inner Drive Collar
3 Sleeve	9 O-ring	15 Outer Drive Collar
4 Locking Collar	10 Canted Spring	16 Shell
5 Inner Stator	11 Inner Rotor	17 Spacer
6 Outer Stator	12 Outer Rotor	

### Before Starting the Equipment

- Check the pump at the coupling for proper alignment of the driver or motor.
- Ensure that the gland plate nuts/bolts are securely tightened according to the pump manual instructions, and that all screws are securely fastened.
- Complete the assembly of the pump, and turn the shaft (by hand if possible) to ensure free rotation.
- Consult all available equipment operating instructions to check for correctness of all piping and connections, particularly regarding seal recirculation/flush, heating or cooling requirements, and services external to the seal.

**ATTENTION**

This mechanical seal is designed to operate in a liquid so the heat energy it creates is adequately removed. The following check should be carried out not only after seal installation, but also after any period of equipment inactivity.

- Check that the seal chamber fluid lines are open and free of any obstruction, and ensure that the seal chamber is properly vented and filled with liquid — refer to the pump instruction manual.

**ATTENTION**

Dry-running — often indicated by a squealing noise from the seal area — will cause overheating and scoring or other damage to the sealing surfaces, resulting in excessive leakage or a much shortened seal life.



**Before startup, ensure that all personnel and assembly equipment have been moved to a safe distance so there is no contact with rotating parts on the pump, seal, coupling or motor.**

### Typical Type 2800MB Seal Arrangement

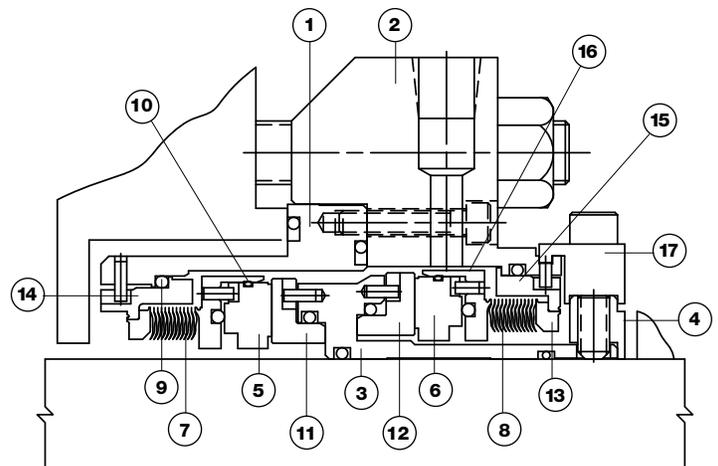

## DUAL CARTRIDGE SEAL

Installation, Operation & Maintenance Instructions

### Operating Conditions

The Type 2800MB is a direct-drive, dry-running, dual cartridge seal, using non-contacting spiral groove technology, and available in metric and inch sizes.

The seal requires a dried and filtered barrier gas supply of plant nitrogen or instrument air maintained at a minimum of 2 barg/30 psig above the seal chamber process fluid pressure. The barrier gas pressure must never drop below the seal chamber pressure.

The selection of materials used in the construction of a seal should be made with respect to the temperature and chemical resistance/ compatibility with the liquid being pumped.

### Operating Limits

Temperature:	-40°C to +275°C/-40°F to +500°F Depending on the materials used
Pressure:	Up to 16 barg/230 psig
Speed:	1450 rpm minimum 3600 rpm maximum

### Lead-On Chamfer

For ease of installation, the lead-on edge of the shaft or sleeve should be chamfered as shown.

\*Above 0635 4.0 mm

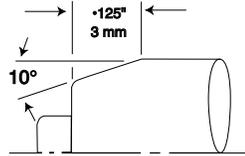

### Housing Squareness To Shaft

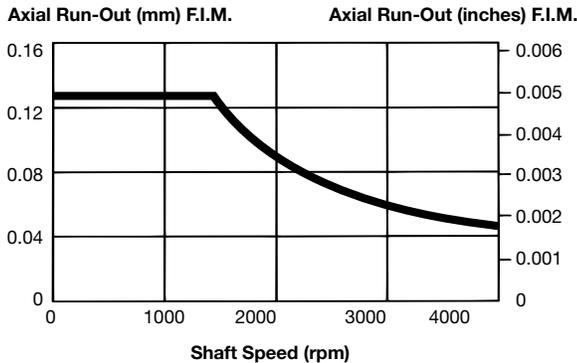

### Checking The Equipment

The Successful operation and life are dependent on acceptable equipment dimensions and alignments. Before installation of the seal, the following dimensional checks should be made with respect to the seal housing/shaft alignments, finish, and lead-on. Normal equipment to measure these features would be a micrometer and a dial indicator.

Shaft/Sleeve Outside Diameters	Refer to Dimension Tables
Seal Chamber Bore Diameter and Depth	Refer to Dimension Tables
Shaft/Sleeve Finish under the Seal Unit	63 Ra (Machined)
Shaft/Sleeve Ovality (out of round)	0.05 mm/0.002 in.
Shaft Axial End Float (End Play)	< 0.08 mm/0.003 in F.I.M.
Seal Housing End Face Squareness to Shaft/Sleeve	Refer to Housing Squareness Graph
Concentricity of the Seal Chamber to the Shaft/Sleeve	0.15 mm/0.006 in F.I.M.
Shaft/Sleeve Run-Out with Respect to the Seal Chamber	< 0.075 mm/0.003 in FIM < 1800 rpm < 0.05 mm/0.002 in FIM < 3600 rpm

**NOTE:** If the measured dimensions exceed those values given, correct the equipment to meet the specifications prior to installing the seal. If the seal is installed on a shaft sleeve, the sleeve must be liquid and pressure tight through its bore.

### Checking The Seal

1. Remove the seal unit from the protective packaging, and visually check the seal exterior generally for any signs of transit damage.

**NOTE:** If the cartridge shows any evidence of damage, the unit should be returned to John Crane for repair.

2. Check that the direction of the pump/equipment shaft rotation is the same as that marked on the seal (gland).

### Installing The Seal

Before starting the installation, read through the following instructions carefully, both to be aware of special information and because the fitting sequence may be different, depending on the construction of the equipment.

1. Adjust the locking collar set screws until they are just clear of the sleeve bore, but remain engaged in the sleeve.
2. With a lubricant comparable with the product and O-ring, sparingly lubricate the sleeve O-ring, sleeve bore, and equipment shaft.

**ATTENTION**



Do not use hydrocarbon or mineral-based lubricants on ethylene propylene O-rings.

**If lubricant should get between the seal face, the seal may not operate properly.**

3. Check that the O-ring is clean, undamaged, and in position, then carefully slide the cartridge fully onto the shaft.
4. Orient the cartridge so that the barrier gas inlet connection is correctly positioned to allow access to the connection.

### Type 2800MB Inch Range Dimensional Data

Seal Dash Number		A +.000	B +.000	C	D	E	F	G	H	J	K	L
Inner	Outer	-0.05mm/-0.002in	-0.05mm/-0.002in	Max.	Min.						(NPT)	(NPT)
-20	-24	1.125 Duriron	2.490	2.750	3.125	1.512	2.093	3.32	.44	5.25	1/4-18	1/4-18
-22	-24	1.125 Goulds	2.615	2.875	3.250	1.655	1.980	3.32	.44	5.25	1/4-18	1/4-18
-24	-26	1.375 Goulds	2.740	2.875	3.375	1.615	1.980	3.56	.44	5.25	1/4-18	1/4-18
-24	-26	1.375 Duriron	2.740	2.875	3.375	1.532	2.095	3.56	.44	5.25	1/4-18	1/4-18
-32	-34	1.750	3.302	3.625	4.125	1.469	2.593	4.44	.56	6.50	1/4-18	1/4-18
-34	-36	1.875	3.370	3.625	4.125	1.330	2.746	4.44	.56	6.00	1/4-18	1/4-18
-38	-40	2.125	3.677	3.875	4.375	1.708	2.521	5.31	.69	7.25	1/4-18	1/4-18
-44	-46	2.500	4.177	4.750	5.250	1.788	2.707	6.06	.69	8.00	1/4-18	1/4-18
-46	-48	2.625	4.365	4.625	5.125	1.550	2.901	5.44	.56	7.00	1/4-18	1/4-18
-48	-50	2.750	4.490	4.750	5.250	2.152	2.532	6.06	.69	8.00	1/4-18	1/4-18

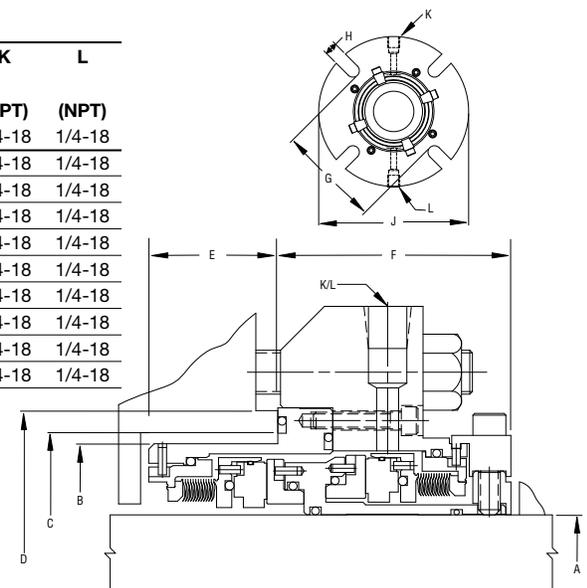

## DUAL CARTRIDGE SEAL

Installation, Operation & Maintenance Instructions

### Installing The Seal (continued)

- Reassemble the equipment, slide the cartridge along the shaft to engage the studs (or align the bolt holes), and push the seal in the housing.
- Place suitably sized washers on the gland plate studs/bolts, and then screw down the nuts/bolts hand-tight only.
- Tighten the gland plate nuts/bolts one nut at a time, alternately, to the recommended torque - see table. Do not overtighten.

**NOTE:** During installation of seal, do not tamper with Permatex®-filled screws.

**NOTE:** Where a torque measuring device is not available, tighten the set screws with the Allen wrench until a torsional twist of 60°-90° is achieved (see Diagram 1). The torque thus applied will approximate to that recommended.

- Lightly and evenly screw down the drive collar set screws to centralize the cartridge on the shaft, then fully tighten the screws to a torque of 4.5 lb ft.

**ATTENTION** The torque values given in the table are the recommended maximum for each of four bolts of the diameter shown: If smaller bolts are used, refer to John Crane for advice. The values given are invalid for reused or sealant-coated gaskets.



Diagram 1

### Recommended Torques for Gland Plate Bolts

Seal Size Code	Metric Bolt Sizes			Inch Bolt Sizes		
	mm	Torque		Inches	Torque	
		Nm	lb ft		Nm	lb ft
0250	10	17	12	7/16	19	14
0280	10	18	13	7/16	20	15
0300	10	19	14	7/16	22	16
0330	10	19	14	7/16	22	16
0350	12	20	15	1/2	23	17
0380	12	22	16	1/2	26	19
0400	12	25	18	1/2	27	20
0430	12	27	20	1/2	29	21
0450	12	29	21	1/2	31	23
0500	12	32	24	1/2	32	24
0550	16	37	27	5/8	37	27
0600	16	52	38	5/8	48	35
0650	16	61	45	5/8	57	42
0800	16	86	63	5/8	90	66
1000	20	148	109	3/4	144	106

### Installing The Seal (continued)

- Remove socket head cap screws and spacers before starting pump.
- Connect the barrier gas supply pipework - refer to Diagram 2.

The barrier gas control system can be piped to either of the two pipe connection ports marked "BI/Drain" in the non-contacting seal gland.

Be sure to plug the port which is not being utilized.

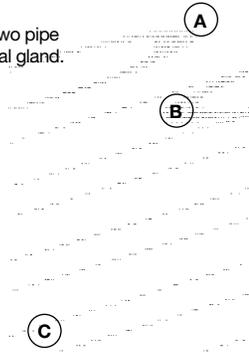

Diagram 2

Connection	Function
A	Barrier gas from BGCS outlet
B	Barrier gas connection to seal
C	Opposite gland port plugged

### Seal Support Systems

The seal requires a clean barrier gas supply at 2 bar/30 psig above seal chamber pressure. A 4 barg/60 psig minimum barrier gas supply pressure is recommended. This barrier gas pressure must never drop below the seal chamber pressure.

If shop air is to be used, or if the gas source is not clean and dry, a moisture trap and a 10-micron filter must be included in the line.

A gas control panel is recommended for optimal system performance and control. Please consult John Crane for the appropriate barrier gas control panel for your particular application.

These systems can be specified to serve the following functions:

- Barrier source regulation
- Barrier consumption measurement
- Detection of barrier pressure drop
- Maintenance of gas integrity
- Process containment on primary seal failure

For further information, contact John Crane Seal Support (918) 599-0991 or John Crane Sealol Metal Bellows (401) 463-8700.

### Piping Connections

The outer gland plate incorporates two pipework connections labeled "BI/Drain."

The barrier gas can be introduced into the gland cavity through either connection. The bottom connection can be used as a drain to check for the presence of liquid in the unlikely event of an inner seal failure. This connection must be plugged during operation.

**ATTENTION** The connection plastic plugs are temporary fittings for storage and transit only, and must not be used for any other purpose. The metal drain plug must not be removed before or during seal operation as barrier gas pressure will be lost.

### Before Commissioning The Equipment

- Ensure that the cartridge locking collar set screws and the gland plate retaining nuts have been correctly tightened.

**ATTENTION** The seal unit must be turned only in the direction indicated by the arrow marked on the unit.

- Complete assembly of the equipment and turn the shaft by hand to ensure free rotation. Check that the direction of rotation of the motor is correct.
- Check that all pipework is correctly connected and the fittings are leak-free, particularly for the barrier gas supply. All lines running between the rotating equipment and the barrier gas control system must be clean and rust-free. Stainless steel lines are recommended. Prior to operation, the lines should be disconnected at the rotating equipment and the barrier gas control system and blown clean with dry, filtered air or nitrogen.

### Before Commissioning The Equipment (continued)

- Pressurize the seal with barrier gas to a minimum of 2 barg/30 psig above the seal chamber pressure or 4 barg/60 psig minimum, whichever is greater. If the seal chamber pressure cannot be specified, the seal should be pressurized to a minimum of 1.5 barg/22 psig above discharge pressure.

**NOTE:** The minimum differential barrier gas pressure required to ensure seal operation is 2 barg/30 psig above the seal chamber pressure.

### Decommissioning The Equipment

- Ensure that the equipment is electrically isolated.



If the equipment has been used on toxic or hazardous fluids, ensure that the equipment is correctly decontaminated and made safe prior to commencing work. Remember that fluid is often trapped during draining and may be present inside the seal chamber. The pump instruction manual should be consulted to check for any special precautions.

- Ensure that the pump is isolated by the appropriate valves. Check that the fluid is drained and pressure fully released.

### Removing The Seal

- Referring to the pump instruction manual, dismantle the equipment sufficiently to expose the cartridge seal and the seal housing.
- Remove the seal unit in the reverse order to installation.

## DUAL CARTRIDGE SEAL

Installation, Operation & Maintenance Instructions

### Standard Seal Support System

1. The John Crane Type 2800MB seal requires a clean barrier gas supply at 30 psig above seal chamber pressure. This barrier gas pressure must never drop below the seal chamber pressure.
2. The Type 2800 control panel is recommended for optimal system performance and control.

This system serves these functions:

- Barrier source regulation
- Barrier consumption measurement
- Detection of barrier pressure drop
- Maintains gas integrity
- Provides process containment in the event of primary seal failure

### System Components

1 Ball Valve	7 Flow Switch
2 Coalescing Filter	8 Tubing Clamp
3 Pressure Regulator	9 Pressure Switch
4 Pressure Gauge	10 Check Valve
5 Flow Meter - Low Range	11 Coupling to Seal
6 Flow Meter - High Range	12 Back Panel

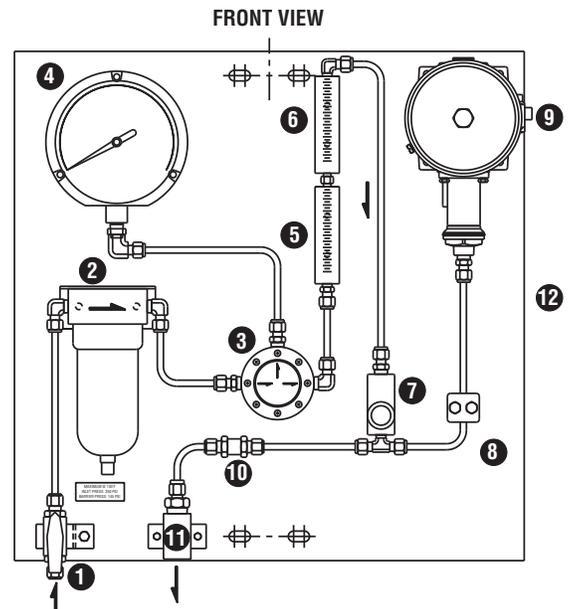

### Maintenance

During operation, periodic inspection of the seal should be carried out. A measure of seal condition is the level of barrier gas consumption; and as no maintenance is possible while installed, the seal should be replaced when consumption becomes unacceptable. It is recommended that a spare seal unit be held in stock to allow immediate replacement of a removed seal.

A cartridge seal must always be serviced after removal from duty. It is recommended that used seals be returned to a John Crane service location since rebuilding to as-new specification must be carried out by qualified personnel.



**It is the responsibility of the equipment user to ensure that any parts being sent to a third party have appropriate safe-handling instructions externally attached to the package.**

### Quality Assurance

This seal has been assembled in accordance with John Crane quality assurance standards, and with proper maintenance and use will give safe and reliable operation to the maximum recommended performance as shown in any relevant approved John Crane publication.

### Storage and Transport

Instructions for the handling, packaging, storage, and transport of seal units and mating rings are given in the John Crane I-Storage, available on request.

Permatex is a registered trademark of Illinois Tool Works Inc



**North America**  
United States of America  
Tel: 1-847-967-2400  
Fax: 1-847-967-3915

**Europe**  
United Kingdom  
Tel: 44-1753-224000  
Fax: 44-1753-224224

**Latin America**  
Brazil  
Tel: 55-11-3371-2500  
Fax: 55-11-3371-2599

**Middle East & Africa**  
United Arab Emirates  
Tel: 971-481-27800  
Fax: 971-488-62830

**Asia Pacific**  
Singapore  
Tel: 65-6518-1800  
Fax: 65-6518-1803

If the products featured will be used in a potentially dangerous and/or hazardous process, your John Crane representative should be consulted prior to their selection and use. In the interest of continuous development, John Crane Companies reserve the right to alter designs and specifications without prior notice. It is dangerous to smoke while handling products made from PTFE. Old and new PTFE products must not be incinerated. ISO 9001 and ISO14001 Certified, details available on request.