

TYPE 75FS

DRY RUNNING FULLY SPLIT MIXER SEAL

Technical Specification

- A – Mating Ring
- B – Sealing Ring
- C – Primary Ring
- D – O-ring
- E – Retainer Assembly
- F – Clamp Ring Assembly
- G – Retaining Plate
- H – Low Head Cap Screw
- I – Gland Plate Assembly
- J – Shoulder Screw

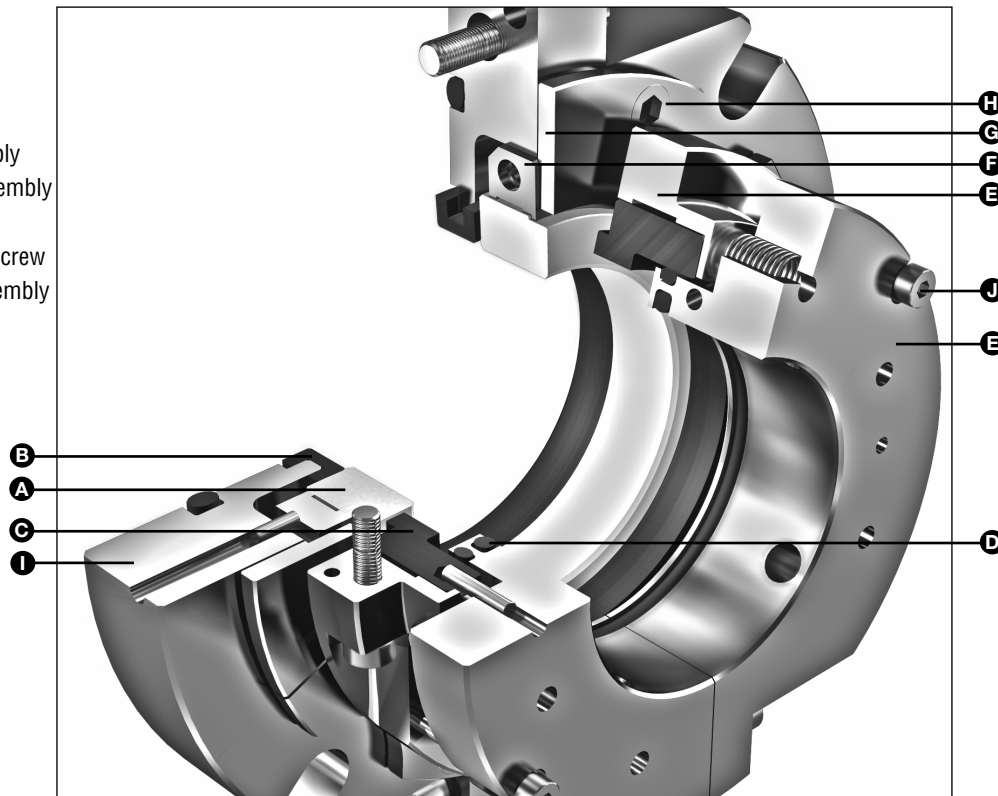

Product Description

The Type 75FS is an engineered, fully split, dry running single seal designed to contain process liquid and vapor while eliminating process contamination. The seal's unique design and features significantly improve reliability and reduce maintenance costs on rotating equipment that previously could not accommodate mechanical shaft seals. Heavy-duty design handles significant shaft movement and runs cool and quiet allowing for cleaner and less hazardous working environment and a more productive process.

- The Type 75FS is ideal for applications on mixers, agitators, and reactors where installation and service is difficult or challenging due to the equipment design or available space.
- Where equipment maintenance is complex and high reliability is vital.
- An excellent choice for chemical processing, food processing, petrochemical, pulp and paper, wastewater, and Pharmaceutical applications where larger shafts and complex coupling or drive arrangements exist.

Performance Capabilities

- Temperature: up to 300° F/150° C
- Pressure: full vacuum to 80 psig/5.5 bar g
- Speed: up to 400 fpm/2 m/s
- Runout: 0.150"/3.81 mm TIR

Design Features

- Heavy duty design accommodates high levels of shaft runout and angular deflection
- Fully split design for ease of installation
- No external lubrication required
- Captive cap screws eliminate lost or dropped screws
- Meets pharmaceutical and chemical processing standards
- Optional debris well allows for easy flushing and sterilization during cleaning cycle (CIP and SIP)
- Captive springs eliminate lost or dropped springs
- Shoulder screws automatically set working height

TYPE 75FS

DRY RUNNING FULLY SPLIT MIXER SEAL

Type 75FS Typical Arrangement

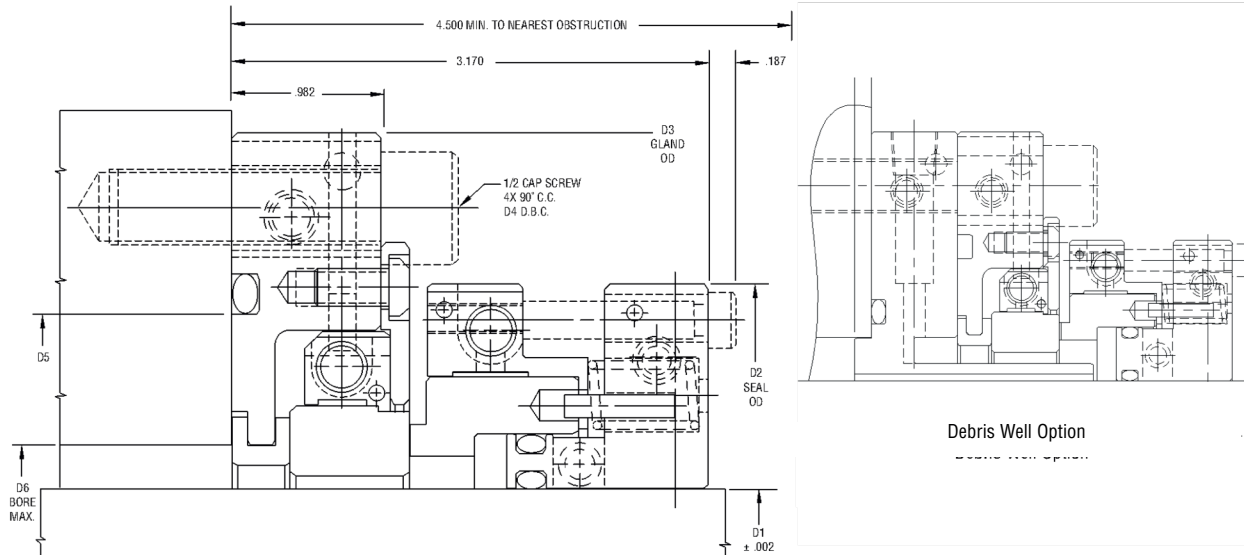

Type 75FS Dimensional Data (inches)

Seal Size	Size Code	D1	D2	D3	D4	D5	D6
2.500	0635	2.500	5.250	7.250	6.250	4.815	3.062
2.750	0698	2.750	5.500	7.500	6.500	5.065	3.312
3.000	0762	3.000	5.750	7.750	6.750	5.315	3.562
3.250	0825	3.250	6.000	8.000	7.000	5.565	3.812
3.500	0889	3.500	6.250	8.250	7.250	5.815	4.062
3.750	0952	3.750	6.500	8.500	7.500	6.065	4.312
4.000	1016	4.000	6.750	8.750	7.750	6.315	4.562
4.250	1079	4.250	7.000	9.000	8.000	6.565	4.812
4.500	1143	4.500	7.250	9.250	8.250	6.815	5.062
4.750	1206	4.750	7.500	9.500	8.500	7.065	5.312
5.000	1270	5.000	7.750	9.750	8.750	7.315	5.562
5.250	1333	5.250	8.000	10.000	9.000	7.565	5.812
5.500	1397	5.500	8.250	10.250	9.250	7.815	6.062
5.750	1460	5.750	8.500	10.500	9.500	8.065	6.312
6.000	1524	6.000	8.750	10.750	9.750	8.315	6.562
6.250	1587	6.250	9.000	11.000	10.000	8.565	6.812
6.500	1651	6.500	9.250	11.250	10.250	8.815	7.062
6.750	1714	6.750	9.500	11.500	10.500	9.065	7.312
7.000	1778	7.000	9.750	11.750	10.750	9.315	7.562
7.250	1841	7.250	10.000	12.000	11.000	9.565	7.812
7.500	1905	7.500	10.250	12.250	11.250	9.815	8.062
7.750	1968	7.750	10.500	12.500	11.500	9.815	8.312
8.000	2032	8.000	10.750	12.750	11.750	10.315	8.562
8.250	2095	8.250	11.000	13.000	12.000	10.315	8.812
8.500	2159	8.500	11.250	13.250	12.250	10.815	9.062
8.750	2222	8.750	11.500	13.500	12.500	10.815	9.312
9.000	2286	9.000	11.750	13.750	12.750	11.315	9.562

TYPE 75FS

DRY RUNNING FULLY SPLIT MIXER SEAL

Pressure/Speed Ratings

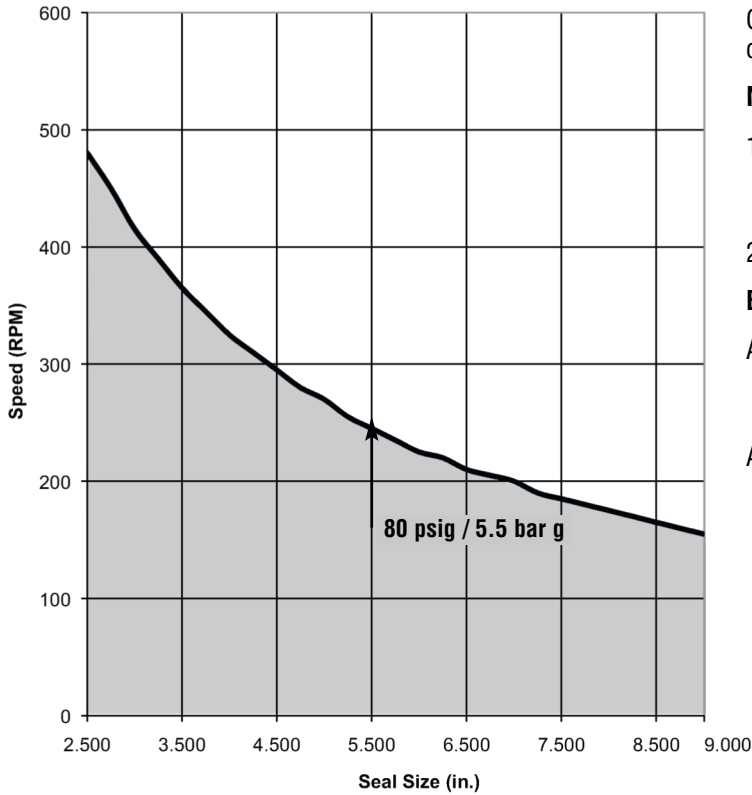

Contact John Crane Engineering for pressure conditions above the curve.

Notes:

1. All seal sizes are capable of handling the rated maximum dynamic pressure of 80 psig / 5.5 bar g.
2. Material combination: carbon vs. ceramic

Example:

Application: Is a 3.000" / 76.2 mm Type 75FS suitable at 50 psig / 3.5 bar g and 350 RPM?

Answer: Yes. The pressure is less than 80 psig / 5.5 bar g and the speed is below the graph line shown. Therefore, a Type 75FS is suitable for the application.

Seal Leakage Rates

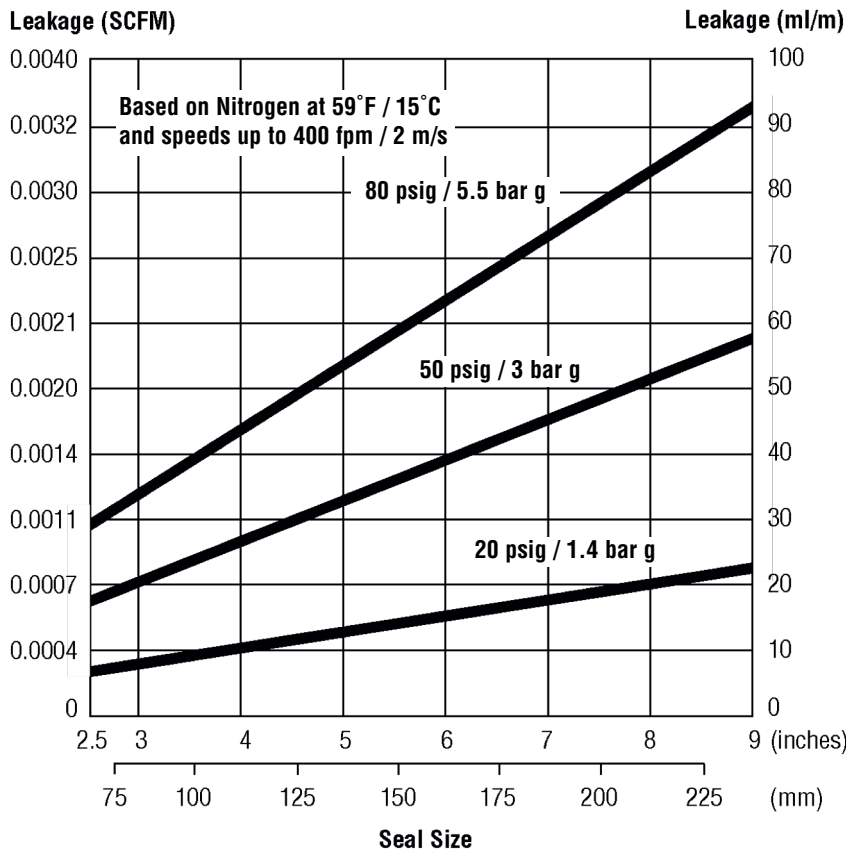

Type 75FS Exploded View Assembly

Part Name

1 Mating Ring	7 Shoulder Screws
2 Sealing Ring	8 Retaining Plate
3 Primary Ring	9 Low Head Cap Screws
4 O-ring	10 Gland Plate Assembly
5 Retainer Assembly	11 Installation Disc
6 Clamp Ring Assembly	

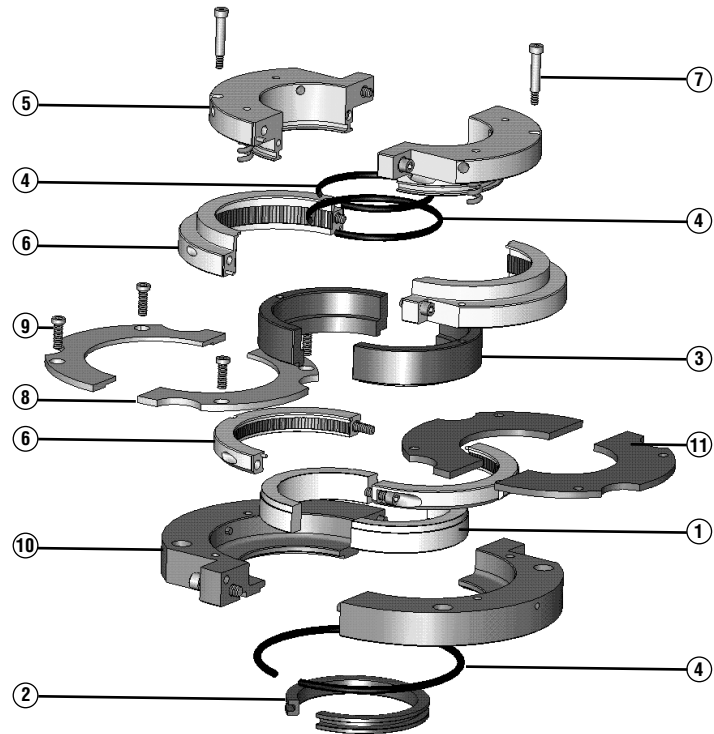

Materials of Construction

SEAL COMPONENTS	MATERIALS	
	Standard	Optional
Description		
Primary Ring	Carbon	-
Mating Ring	Ceramic	-
Primary Ring Clamp Ring Assembly (clamp ring, tolerance ring, cap screw)	Alloy 42, Alloy K-500, 316 SS (Note 2)	-
Mating Ring Clamp Ring Assembly (clamp ring, tolerance ring, cap screw)	Alloy 42, Alloy K-500, 316 SS (Note 2)	-
Retainer Assembly (retainer, spring, cap screw, set screw, retaining ring)	316 SS, Hardened 410 SS, 18-8 SS	Alloy C-276
Gland Plate Assembly (gland plate, cap screw)	316 SS	Alloy C-276
Sealing Ring	Fluoroelastomer	EPDM, Nitrile, TFE Propylene
O-ring	Fluoroelastomer	EPDM, Nitrile, TFE Propylene
Retaining Plate, Installation Disc, Low Head Cap Screw	316 SS	Alloy C-276
Shoulder Screw	Hardened Steel	-

Notes:

- Standard Type 75FS seal face materials are FDA (GRAS) compliant.
- No substitutions.



North America
United States of America
Tel: 1-847-967-2400
Fax: 1-847-967-3915

Europe
United Kingdom
Tel: 44-1753-224000
Fax: 44-1753-224224

Latin America
Brazil
Tel: 55-11-3371-2500
Fax: 55-11-3371-2599

Middle East & Africa
United Arab Emirates
Tel: 971-481-27800
Fax: 971-488-62830

Asia Pacific
Singapore
Tel: 65-6518-1800
Fax: 65-6518-1803

If the products featured will be used in a potentially dangerous and/or hazardous process, your John Crane representative should be consulted prior to their selection and use. In the interest of continuous development, John Crane Companies reserve the right to alter designs and specifications without prior notice. It is dangerous to smoke while handling products made from PTFE. Old and new PTFE products must not be incinerated. ISO 9001 and ISO14001 Certified, details available on request.