

Mechanical Seals for Sulzer Ahlstar Pumps



Safematic® Type SE1, SEW and SE2

Safeseal Type SE1

Simple design, good technical solutions

Typical applications

Safeseal Type SE1 is a special seal designed for clean and lubricating fluids such as water, different types of oils, solvents, and stock (consistency $\leq 2\%$). It is typically used in pumps in paper and board mills as well as in power plants. Type SE1 is designed especially for Sulzer APP and APT pump series.

Type SE1 is easy to install and maintain. In spite of its simple design, Type SE1 is very advanced in its technical capabilities including, for example, a patented thermal method for seal face holding and an elastic thrust ring.

Features and benefits

1. Balanced design - Undisturbed operation even with sudden pressure shocks.
2. Spring located in the stationary body of the seal - Shaft misalignment does not pump up the spring or wear out the O-ring.

3. SiC/Carbon a standard option for seal faces SiC/Carbon holds up well under high speeds found in, for example, condensate pumps and other high temperature pumps.
4. Installation against the shaft shoulder - Easy installation reduces risk of human error. No measurements required for installation.
5. No drive pins at seals - Seal face does not crack at start-up.
6. Available in different materials - Selection covers all possible single seal applications.

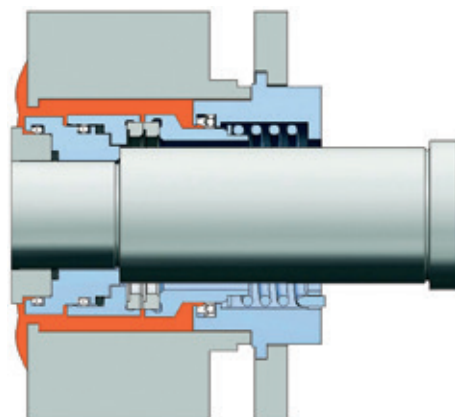

Technical specifications

Temperature	250°F/121°C max
Stuffing box pressure	220 psig/15 barg max
Speed	4,000 fpm/20 m·s ⁻¹ max

Materials

Seal faces	SiC/Carbon or SiC/SiC
O-rings	EPDM PTFE Viton® FFKM
Metals	Standard material AISI 329/ AISI 316 (Titanium, Alloy 20)
Spring	AISI 316

Safeseal Type SEW

A reliable, long-lasting seal for demanding conditions

Typical applications

Type SEW is a seal operating on a non-pressurised water rinsing (quench) principle, and it is designed for the most demanding applications in the pulp industry, where reliable and long-lasting operation is required from a seal. Typical applications include stock pumps at pulp mill washing and screening facilities as well as high temperature condensate pumps. Type SEW seal is especially designed for Sulzer APP and APT pump series.

Features and benefits

1. Balanced design - Undisturbed operation even with sudden pressure shocks.
2. Spring located in a stationary body - Shaft misalignment does not pump up the spring or wear out the O-ring.
3. Installation against the shaft shoulder - Easy installation reduces risk of human error. No measurements required for installation.

4. No drive pins at seals - Seal face does not crack at start-up.
5. Available in different materials - Selection covers all possible single seal applications.
6. Non-pressurised seal water rinsing (quench) - Possible to cool seal with non-pressurised seal water at high temperatures. V-ring prevents water leakage from the seal.



Technical specifications

Temperature	300°F/150°C max
Stuffing box pressure	220 psig/15 barg max
Speed	4,000 fpm/20 m·s ⁻¹ max

Materials

Seal faces	SiC/Carbon or SiC/SiC
O-rings	EPDM PTFE Viton®
Metals	FFKM Standard material AISI 329/ AISI 316 (Titanium, Alloy 20)
Spring	AISI 316

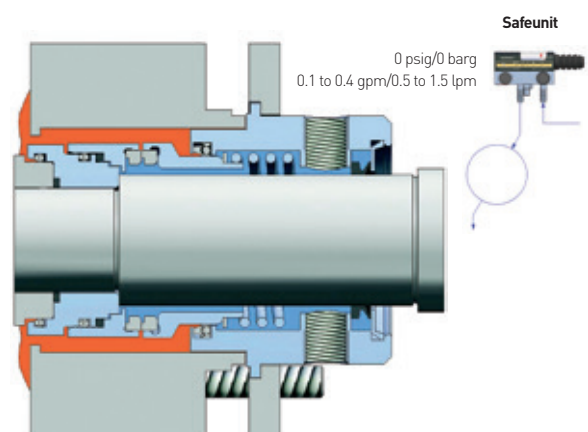

Safeseal Type SE2

Double-balanced design, ultimate reliability

Typical applications

The double-balanced design of Safeseal Type SE2 ensures reliable and long-lasting operation under the most demanding conditions. This seal is typically used in pumps for abrasive and environmentally hazardous liquids in cooking, evaporation and causticising facilities in pulp mills. Type SE2 is especially designed for Sulzer APP and APT pump series.

Features and benefits

1. Seal faces are fastened by a patented thermal heat shrink method, which ensures correct face alignment at all temperatures recommended for this seal.
2. The springs are located in the stationary body on piston ring of the seal in the seal water. This allows the seal water to rinse the springs continuously, preventing corrosion by process chemicals. In addition, spring jams decrease. Shaft misalignment does not pump up springs or wear out O-rings.
3. The piston-type design of the seal enables free axial movement, therefore axial movement does not have any impact on seal face pressure.

4. Even in standard models, PTFE slot rings in positions where they are exposed to the product have replaced traditional O-rings. The PTFE seal advantage is that it does not jam even in high solid content process conditions.
5. Milled slots are used to prevent stationary seal faces inside face carriers from rotating. This prevents tension that would distort the seal face.
6. The special double-balanced design allows the use of both pressurised and non-pressurised seal water regardless of process pressure ensuring that seal faces will not open.

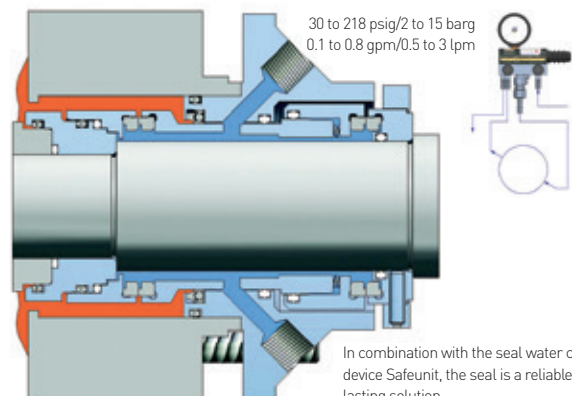
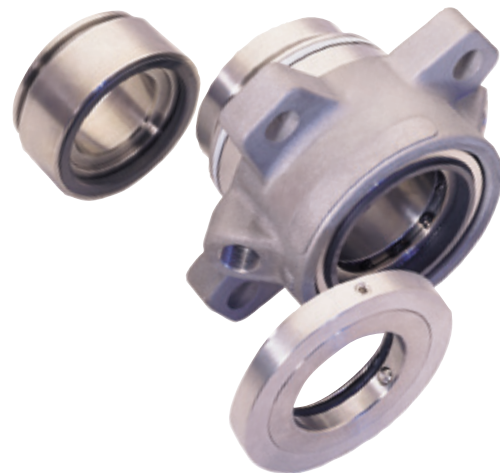

Technical specifications

Temperature	356°F/180°C max
Stuffing box pressure	290 psig/20 barg max
Seal water pressure	220 psig/15 barg
Speed	4,000 fpm/20 m·s ⁻¹ max

Materials

Seal faces	SiC/SiC (product side) SiC/Carbon (atmosphere side)
O-rings	EPDM PTFE Viton® FFKM
Metals	Standard material AISI 329/ AISI 316 (Titanium, Alloy 20)
Springs	Nimonic

Mechanical Seals for Sulzer Ahlstar Pumps

Mechanical Sealing Systems

Type SE Seal Identification Codes

E.g. SE2-AP-50-QRMG-305123

XXX-XX-X₁X₂X₃X₄-XXXXXX

① ② ③ ④

① Type of seal
SE1: single seal
SEW: quench wash seal
SE2: double seal

② Shaft diameter: (in, mm)

③ Material codes:

X₁ = inboard faces

Q-SiC/SiC
G-SiC/Carbon

X₂ = wetted metals

R-AISI 316/329
T-Titanium
U-UHB 904 L

X₃ = elastomers

M-PTFE
E-EPDM
V-Viton®

X₄ = outboard faces

O- Single seal
G-SiC/Carbon
V- V-ring (quench)

④ Drawing number

P/P1= early versions of design
AP= latest seal version

John Crane has a comprehensive network of highly trained representatives, distributors, and installation and maintenance personnel. Contact your local John Crane sales office for more information.

John Crane Safematic Seal Support Systems

Optimize seal operation and performance

Safeunit Ultima

Optimizes seal performance in extreme conditions

Specially designed to control seal water flow and pressure in a wide range of extreme conditions, John Crane's Safeunit Ultima increases the reliability of seals in pumps and process machinery while reducing seal water consumption by up to 80 percent. It is intended for use in harsh operating environments where high temperature, high pressure and chemically aggressive elements are present. This makes it ideal for pulp, paper and chemical industry applications, plus a wide variety of mining and general industrial uses.

The easy-to-install Safeunit Ultima controls and monitors seal water flow and pressure, while also drastically reducing overall consumption levels. Sealing reliability is increased and equipment uptime is extended, while shutdown time and maintenance costs are reduced.

Features and advantages

- An advanced design which reduces pressure loss
- A rugged, heavy-duty structure
- Patented cleaning plunger which cleans the display and check valve during operation
- Improved accuracy
- Excellent resistance to chemical attack and corrosion
- A proven regulating valve design which enhances seal reliability
- Greater operating temperature capability (up to 212°F/100°C)
- An optional 725 psig/50 barg pressure capability

A reliable method of optimizing sealing performance



**Type SUP
for flush and packing**



**Type SUQ
for non pressurized quench**



**Type SUD
for double seals**



John Crane Safematic Seal Support Systems



Features and advantages

- Controls and monitors seal water flow and pressure
- Predicts seal and packing failures
- Anticipates seal water requirements and reduces consumption
- Can be cleaned with equipment running - improved push-clean button ensures alarm will not trigger
- Simplifies pump setup and service
- Detects and locates seal water line problems
- Includes flow indicator and pressure gauge with memory pin
- Features unique non-clog valves
- Optional electrical alarms

Safeunit

Complete seal water monitoring and control unit

Safeunit seal water monitoring and control system ensures trouble-free operation for process machinery in all types of operating environments. By monitoring and adjusting the seal water flow rate and pressure, Safeunit creates the optimum operating environment for a mechanical seal. This significantly improves the reliability of the process involved, helps achieve maximum efficiency and so generates the greatest return on investment.

A self-contained and compact unit for easy seal maintenance

Packing or single seal flush



Type SFP



Quench seal



Type SFQ



Double mechanical seal



Type SFD





YOUR NAME IS HOW WE MAKE OURS



□□□□



Global Service Network

- » Over 200 facilities in more than 50 countries
- » Close proximity to customers' operations
- » Local service and expert global support

North America

United States of America
Tel: 1-847-967-2400

Europe

United Kingdom
Tel: 44-1753-224000

Latin America

Brazil
Tel: 55-11-3371-2500

Middle East & Africa

United Arab Emirates
Tel: 971-481-27800

Asia Pacific

Singapore
Tel: 65-6518-1800



If the products featured will be used in a potentially dangerous and/or hazardous process, your John Crane representative should be consulted prior to their selection and use. In the interest of continuous development, John Crane companies reserve the right to alter designs and specifications without prior notice. It is dangerous to smoke while handling products made of PTFE. Old and new PTFE products must not be incinerated. ISO 9001 and ISO 14001 Certified, details available on request.